

SPECIFICATION MANUAL

TLM Project No. J-6746D
Issue Date: August 21, 2023

HOLLOW ROCK SEMINARY STREET SERVICE LINE REPLACEMENT

for

Town of Hollow Rock

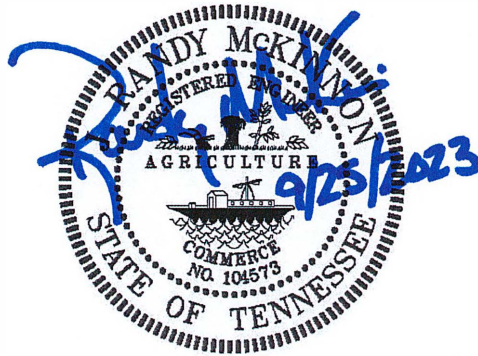

TLM

ASSOCIATES

Architects + Engineers

117 East Lafayette Street

Jackson, TN 38301

Phone: 731-988-9840

Fax: 731-988-9959

visit us at www.tlmae.com

HOLLOW ROCK SEMINARY STREET SERVICE LINE REPLACEMENT

TLM Project No. J-6746D

TABLE OF CONTENTS

| <u>Title Page</u> | <u>No. of Pages</u> |
|---|---|
| DIVISION 0 – PROCUREMENT AND CONTRACT REQUIREMENTS | |
| Section 00 11 13 | Advertisement for Bids..... 2 |
| Section 00 21 13 | Instructions to Bidders 7 |
| Section 00 41 43 | Bid Form 2 |
| Section 00 43 13 | Bid Bond 1 |
| Section 00 45 49 | Drug-Free Workplace Affidavit..... 1 |
| | BYRD Anti-Lobbying Amendment Certification..... 2 |
| | Iran Divestment Act Certification..... 1 |
| | Certification Regarding Debarment, Suspension and Other Responsibility Matters..... 1 |
| | Non-Boycott of Israel Certification..... 1 |
| | Certification by Proposed Prime or Subcontractor Regarding Equal Employment Opportunity 1 |
| | Acknowledgement Regarding Bidder SAM Registration..... 1 |
| | Certification of Contractor Regarding Conflicts of Interest, Lobbying, Nondiscrimination, Public Accountability, and Public Notice 3 |
| | Notice Recipient of State and Federal Funds 1 |
| | State Water Infrastructure Grants Identification Sign 1 |
| Section 00 51 00 | Notice of Award..... 1 |
| Section 00 52 00 | Agreement Form 2 |
| Section 00 55 00 | Notice to Proceed..... 1 |
| Section 00 61 00 | Bonds and Certificates..... 1 |
| Section 00 61 13.13 | Performance Bond 2 |
| Section 00 61 13.16 | Payment Bond 2 |
| Section 00 72 00 | General Conditions..... 1 |
| | EJCDC General Conditions 72 |
| Section 00 72 10 | Supplemental General Conditions 11 |
| Section 00 73 00 | Special Conditions 6 |
| DIVISION 1 – GENERAL REQUIREMENTS | |
| Section 01 11 00 | Summary of Work 3 |
| Section 01 21 46 | Weather Delays 2 |
| Section 01 26 63 | Change Orders Procedures..... 4 |
| Section 01 29 00 | Payment Procedures 2 |

| | | |
|--|---|----|
| Section 01 32 16 | Construction Progress Schedule..... | 3 |
| Section 01 33 00 | Submittal Procedures..... | 4 |
| Section 01 42 00 | References..... | 2 |
| Section 01 74 00 | Cleaning..... | 2 |
| Section 01 77 00 | Closeout Procedures | 6 |
| DIVISION 31 – EARTHWORK | | |
| Section 31 10 00 | Site Clearing..... | 3 |
| Section 31 23 01 | Trenching, Backfilling, and Compaction..... | 9 |
| Section 31 25 01 | Erosion Control..... | 7 |
| DIVISION 32 – EXTERIOR IMPROVEMENTS | | |
| Section 32 12 16 | Asphalt Paving..... | 4 |
| Section 32 92 19 | Seeding | 5 |
| DIVISION 33 – UTILITIES | | |
| Section 33 10 00 | Water Distribution Systems | 14 |
| Section 32 21 00 | Separation of Piped Utilities | 2 |
| ATTACHMENT I | | |
| | Service Line Replacement Detail..... | 1 |
| ATTACHMENT II | | |
| | Service Line Map..... | 1 |

DIVISION 0

**PROCUREMENT AND
CONTRACT REQUIREMENTS**

SECTION 00 11 13 - ADVERTISEMENT FOR BIDS

The Town of Hollow Rock will receive separate sealed bids for the construction of a water project at 27960 Broad St., Hollow Rock, TN 38342, on May 22, 2024, until 10:00 am, local time, and then at said office publicly opened and read aloud. Any person with a disability requiring special accommodation must contact the Town of Hollow Rock no later than 7 days prior to the bid opening.

The work to be bid on is as follows:

- Replacement of **48** water service lines, including curb stops on Seminary St.
- The allotted time for construction is **90** calendar days for water service line replacement.

This project is being supported with the Treasury, Coronavirus State and Local Recovery Fund grant funding. Therefore, certain restrictions and other federal requirements attach to this opportunity.

All bid documents may be examined and obtained at the following: TLM Associates, Inc. 117 E. Lafayette St., Jackson, TN 38301. Hard copy sets require a \$150 refundable deposit. A digital set may be obtained at no charge. Payment may be made by check, credit card, or ACH by contacting our office at 731-988-9840 or receptionist@tlmae.com.

Any non-winning bidder or non-bidder, upon returning the CONTRACT DOCUMENTS after BID opening and in good condition, will be refunded his/her payment.

The Town of Hollow Rock hereby notifies all bidders that it will affirmatively ensure that in any contract entered pursuant to this advertisement will be afforded full opportunity to submit bids in response to this invitation and will not be discriminated against on the grounds of race, color, sex, or national origin in consideration for an award. The Town of Hollow Rock is an Equal Opportunity Employer. Any contract that uses federal funds to pay for construction work is a “federally assisted construction contract” and must include the equal opportunity clause found in 2 C.F.R. Part 200, unless otherwise stated in 41 C.F.R. Part 60. We encourage all small and minority owned firms and women’s business enterprises to participate. No bidder may withdraw his bid within (60) days after the actual date of the opening thereof.

PLEASE NOTE: Official plan holders list will only be the list maintained by TLM Associates, Inc. It is the sole responsibility of all plan holders, whether they have received digital downloads or paper copies of the plans and specifications, to periodically check for Addenda which may have been posted on the following websites:

- Go-DBE, www.tn.gov/generalservices/procurement/central-procurement-office--cpo-/go-dbe
- Builder’s Exchange, www.bxtn.org
- Dodge Data & Analytics, dodge.docs@construction.com
- West Tennessee Plans Room, www.wtplanroom.com

All bidders are required to be licensed in accordance with the General Licensing Act of 1976 (TCA Title 62, Chapter 6), also known as House Bill No. 2180.

The Copeland "Anti-Kickback" Act is also applicable, which prohibits workers on construction contracts from giving up wages that they are owed. Contractors must not appear on the Sam.gov debarment list.

A detailed listing of all subcontractors shall be provided by the Bidder. In accordance with the Contract Documents, documentation that the prospective General Contractor and its subcontractors meet minimum qualifications shall be provided and submitted. Subcontractors must also not appear on the Sam.gov disbarment list. Mark-ups on subcontractor work or Cost-Plus Overhead will be disallowed for reimbursement.

A bid bond or certified check for five percent (5%) of the total bid amount must accompany each bid. The successful bidder will be required to furnish a performance bond in the amount of his bid and shall, before entering on the work of said contract, be licensed as a contractor of the Town of Hollow Rock.

The owner reserves the right to waive any informalities or to reject any or all bids.

Supplemental Conditions

Required State or Grantee Certifications

The following documents outline required supplementary requirements to be completed and provided by the bidders with your bid response.

- [BYRD Anti-Lobbying Amendment Certification](#)
- [Iran Divestment Act Certification](#)
- [Debarment Certification](#)
- [Non-Boycott of Israel Certification](#)

Required and Recommended Federal Contract Provisions

The following documents outline the required and recommended provisions that must be included in contracts that are being funded in part or whole with grant funding from the SLFRF.

- [Required and Recommended SLFRF Supplemental Conditions for Contracts Provisions](#)
- [Davis-Bacon and Certification of Labor Agreements Reporting Template](#) (for projects greater than \$10 million)

Required Construction Site Signage

- **Identification Signage for Individual Projects Going to Construction**
 - [State Water Infrastructure Grants Project Sign Sample](#)
- **Wage Rates** – every employer performing work covered by the labor standards of the Davis-Bacon and Related Acts shall post a notice (including an applicable wage determination) at the site of the work in a prominent and accessible place where it may be easily seen by employees.
- **Permits** – a copy of all applicable permits must be posted on-site for the duration of the permit(s) and be installed in accordance with all permit requirements.

SECTION 00 21 13 - INSTRUCTIONS TO BIDDERS

PART 1 - DOCUMENTS

1.1 BID FORMS AND BID PREPARATIONS

- A. Bid Forms and Bid Preparation: A State Contractor's license will be required for work over \$25,000.
- B. All Bids will be submitted on forms contained herein and shall be subject to all requirements of the specifications and drawings. Bid forms shall not be removed from the project manual.
- C. All blank spaces for Bid prices must be filled in, in ink or typewritten, in both words and figures.
- D. In case of an error in the extension of prices in the bid, for a unit price bid, the unit price shall govern.
- E. No bid shall be altered, amended, or withdrawn after the specified time for opening the bids. Negligence on the part of the Bidder in preparing the Bid confers no right for the withdrawal of the Bid after it has been opened.
- F. By the General Contractors Licensing Act of 1976 and T.C.A. 62-6-119 of 1994, each Bidder must submit the following information for his Bid to be considered valid. Each Bid must be submitted in a sealed envelope bearing on the outside the following information:
 - 1. Name of Bidder.
 - 2. Address of Bidder, including Zip Code and Phone Number, to show whether Bidder is a resident of the State of Tennessee.
 - 3. Tennessee License Number of Bidder.
 - 4. Expiration Date of Tennessee License Number.
 - 5. The Classification of Bidder's License which applies to this Bid/Bidder must write out the work classifications of his license which apply to the work of this project.
 - 6. Name of the Project for which the Bid is submitted.
 - 7. List Subcontractors, License Number, Expiration Date thereof, and License Classification for the following subcontractors on the outside of the envelope containing the Bid:
 - a. Electrical
 - b. Plumbing
 - c. Heating, Ventilation, & Air Conditioning.
 - 8. Quoting from TCA 62-6-119, "Any Bid envelope which contains the listing of more than one contractor in each classification shall be considered in violation. Failure to observe this section constitutes a Class A Misdemeanor."
- G. If forwarded by mail, the sealed envelope containing the Bid must be enclosed in another envelope addressed as specified in the Proposal Form.

- H. Each bid must be submitted on the prescribed form and accompanied by Certification of Bidder Regarding Equal Employment Opportunity, Acknowledgment Regarding Bidder SAM Registration, Certification of Bidder Regarding Section 3 and Segregated Facilities, and Drug-Free Workplace Affidavit. All blank spaces for bid prices must be filled in, in ink or typewritten, in both words and figures, and the foregoing Certifications must be fully completed and executed when submitted.
- I. Conditional, telegraphic, low total and "all or none" bids will not be accepted.
- J. Contractor's License Requirements: The following is excerpted from the Contractor's Licensing Act of 1976:
 - 1. 62-6-103. Contractor's License Required -- Recovery of Expenses by Unlicensed Contractor.
 - a. Any person, firm or corporation engaged in contracting in this state shall be required to submit evidence that he is qualified to engage in contracting, and shall be licensed as hereinafter provided; it shall be unlawful for any person, firm or corporation to engage in or offer to engage in contracting in the state, unless such person, firm or corporation has been duly licensed under the provisions of this chapter, as hereinafter provided. Any person, firm, or corporation engaged in contracting, including such person, firm, or corporation that engages in the construction of residences or dwellings constructed on private property for the purpose of resale, lease, rent or any other similar purpose shall be required to submit evidence that he is qualified to engage in contracting and/or building, and shall be licensed. It shall be unlawful for any person, firm, or corporation to engage in, or offer to engage in contracting or building as hereinabove described, unless such person, firm or corporation has been duly licensed under the provisions of this chapter. Any person, firm, or church that owns property and buildings for individual use, and not for resale, lease, rent or other similar purpose, is exempt from the requirements of this chapter. Notwithstanding the foregoing, the license of any person, firm or corporation licensed as a General Contractor on March 29, 1976, shall continue in force until the natural expiration thereof.
 - b. Contracts entered into by a person who is licensed by the Board shall clearly state that such person is licensed by the State Board for Licensing Contractors and that the Board is authorized to receive complaints relative to such person's professional conduct.
 - c. Any unlicensed General Contractor covered by the provisions of this chapter shall be permitted in a court of equity to recover actual documented expenses only upon a showing of clear and convincing proof. (Acts 1976 (Adj. S.), Ch. 822, Section 3; 1977, Ch. 9, Section 1; 1979, Ch. 59, Section 7; 1980 (Adj. S.), Ch. 652, Section 5; T.C.A., Section 62-603.)
- K. Examination of Site: Bidders shall visit the site of the project, and the Contractor shall be assumed to have visited the premises and to have allowed for all conditions that might affect his work. No consideration will be given to any claim based on lack of knowledge of existing conditions.

- L. **Obligation of Bidder:** Bidders shall notify the Engineer immediately, should during his examination of the site or any of the associated documents, he finds a discrepancy. At the time of the Opening of Bids, each Bidder will be presumed to have inspected the site and to have read and be thoroughly familiar with Plans and Contract Documents (including all addenda). Failure or omission of any Bidder to examine any form, instrument or document shall in no way relieve any Bidder from any obligation in respect to the Bid.
- M. **Conditions of Work:** Each Bidder must inform himself fully of the conditions relating to the construction of the project and the employment of labor thereon. Failure to do so will not relieve a successful Bidder of his obligation to furnish all material and labor necessary to carry out the provisions of his Contract. Employ such means and methods that will not cause any interruptions or interference with work by others.

1.2 ADDENDA

- A. **Interpretations and Addenda:** The Engineer will make every effort necessary to cooperate with Bidders in making the proper interpretations of the Contract Documents and in advising all Bidders of such interpretation.
- B. **Questions from Bidders must be directed to the Engineer as soon as possible to allow sufficient time for preparation and distribution of addenda.** When written addenda are required, they will be mailed to each prime Bidder, (at the respective addresses furnished for such purposes). It shall be the Bidder's responsibility to make inquiry as to addenda issued. All such addenda shall become a part of the Contract and all Bidders shall be bound by such addenda, whether they are received by the Bidders, or not.
- C. **Deadline for Interpretations and Questions:** Five (5) days before Bid date.
- D. **Responsibility of General Contractor to Subcontractor Regarding Addenda:** Addenda will be e-mailed and/or faxed to each prime Bidder (i.e., General Contractor.) Copies of addenda will also be e-mailed and/or faxed to construction plans rooms, but not to the subcontractors. It shall be the responsibility of each prime Bidder to forward copies of addenda or otherwise inform their subcontractors of any and all addenda issued.

1.3 BID SECURITY

- A. **Bid Guaranty (Bid Bond):** The Bid must be accompanied by a Bid Guaranty that shall not be less than 5 percent (5%) of the amount of the Bid, and at the option of the Bidder may be a Certified Check, bank draft, U. S. Government Bonds at par value, or a Bid Bond secured by a surety company. Certified check or bank draft must be made payable to the order of the Owner. The Bid Guaranty shall insure the execution of the Contract and the furnishing of performance and payment bond or bonds by the successful Bidder all as required by the specifications. If the successful Bidder withdraws his Bid within sixty (60) days of the Bid Opening, then his Bid Bond will automatically be forfeited to the Owner.

PART 2 - CONSIDERATIONS OF THE BID

2.1 BIDDER(S) CONSTRUCTION EXPERIENCE

- A. Before a Bid is considered for award, the Bidder may be requested by the Owner to submit a statement regarding his previous experience in performing comparable work, his business and technical organization, and financial resources.

2.2 QUALIFICATIONS OF BIDDERS

- A. Bids are acceptable only from Contractors properly and currently licensed.
- B. The Bidder is advised that any person, firm, or other party to whom it is proposed to award a subcontract under this Contract, must be acceptable to the Owner and/or Architect.
- C. The Owner may make such investigations as she/he deems necessary to determine the ability of the bidder to perform the work, and the bidder shall furnish to the Owner all such information and data for this purpose as the Owner may request. The Owner reserves the right to reject any bid if the evidence submitted by, or investigation of, such bidder fails to satisfy the owner that such bidder is properly qualified to carry out the obligations of the contract and to complete the work contemplated therein. Conditional bids will not be accepted.

2.3 RECEIVING BIDS

- A. Bids received prior to the time of opening will be securely kept, unopened. The officer whose duty it is to open them will decide when the specified time has arrived, and no Bid received thereafter will be considered; except that when a Bid arrived by mail after the time fixed for opening, but before award is made, and it is shown to the satisfaction of the officer authorized to make the award that the non-arrival on time was due solely to delay in the mails for which the Bidder was not responsible, such Bid will be received and considered. No responsibility will be attached to an officer for the premature opening of a Bid not properly addressed and identified. Unless specifically authorized, telegraphic Bids will not be considered.
- B. Opening of Bids: Bids will be publicly opened at the time and place fixed for the Opening of Bids. Every Bid received within the time fixed for receiving Bids will be opened and the results made known.
- C. Telegraphic Bids: Telegraphic bids received before the time set for opening of bids will be considered if immediately confirmed by mail on standard bid form.
- D. Lot Bids: Low total and all or none bids will not be considered, and in all cases, bid must show unit prices for each item.

- E. Withdrawal of Bids: Bids may be withdrawn on written or telegraphic request dispatched by the Bidder in time for delivery in the normal course of business prior to the time fixed for opening; provided, that written confirmation of any telegraphic withdrawal over the signature of the Bidder is placed in the mail and postmarked prior to the time set for Bid Opening. Negligence on the part of the Bidder in preparing his Bid confers no right of withdrawal or modification of his Bid after such Bid has been opened.
- F. Error in Bid: In case of error in the extension of prices in the bid, the unit price will govern. No Bid shall be altered, amended, or withdrawn after the specified time for opening bids. Negligence on the part of the Bidder in preparing the Bid confers no right for the withdrawal of the Bid after it has been opened.

2.4 AWARD OF CONTRACT

- A. The Contract will be awarded to the responsible Bidder submitting the lowest proposal complying with the conditions of the Invitation to Bid, provided his Bid is reasonable and it is to the best interest of the Owner, at the earliest practicable date. The Owner, however, reserves the right to reject any and all Bids and to waive any informality in Bids received whenever such rejection or waiver is in the interest of the Owner.
- B. The Owner also reserves the right to reject the Bid of any Bidder who has previously failed to perform properly, or to complete on time, contracts of a similar nature, who is not in a position to perform the Contract, or who has habitually and without just cause neglected the payment of bills or otherwise disregarded his obligations to subcontractors, material men, or employees.
- C. The ability of a Bidder to obtain a performance bond shall not be regarded as the sole test of such Bidder's competency or responsibility.

2.5 PERFORMANCE AND PAYMENT BOND

- A. Performance and Payment Bond, Execution of Contract: Subsequent to the award and within ten days after the prescribed forms are presented for signature the successful Bidder shall execute and deliver to the Owner a Contract in the form furnished in such number of counterparts as the Owner may require.
- B. Having satisfied all conditions of award as set forth elsewhere in these documents, the successful Bidder shall, within the period specified above, furnish bond(s) in a penal sum of at least the full amount of the Contract as awarded, in the form included in the specifications, which secures the faithful performance of the Contract, and for the payment of all persons, firms, or corporations to whom the Contractor may become legally indebted for labor, materials, tools equipment or services of any nature employed or used by him in performing the work. Such bond(s) shall bear the same date as or a date subsequent to, the date of the Contract.
 - 1. The current power of attorney for the person who signs for any surety company shall be attached to such Bond.

- C. The failure of the successful Bidder to execute such Contract and to supply the required bonds within ten days after the prescribed forms are presented for signature, or within such extended period as the Owner may grant based upon reasons determined adequate by the Owner shall constitute a default, and the Owner may either award the Contract to the next responsible Bidder or re-advertise for Bids, and may charge against the Bidder the difference between the amount of the Bid and the amount for which a Contract for the work is subsequently executed, irrespective of whether the amount thus due exceeds the amount of the Bid Guaranty.

PART 3 - POST BID

3.1 PRE-CONSTRUCTION CONFERENCE

- A. Either before or soon after the actual award of the Contract (but in any event prior to the start of construction), the Contractor or his representative shall attend a pre-construction conference with representatives of the Owner. The Conference will serve to acquaint the participants with the General Plan of Contract Administration and requirements under which the construction operation is to proceed and will inform the Contractor of the obligations imposed on him and his subcontractors.
- B. The date, time, and place of the Conference will be furnished to the Contractor by the Architect.

3.2 LAWS & REGULATIONS

- A. The Bidder's attention is directed to the fact that all applicable State laws, municipal ordinances, and the rules and regulations of all authorities having jurisdiction over construction of the project shall apply to the Contract throughout and they will be deemed to be included in the Contract the same as though herein written out in full.
- B. The Contractor and all subcontractors shall further comply with applicable building codes as referenced in the various sections of these Specifications.
- C. The Contractor shall include, either on the Bid form or attached thereto, a statement to the fact that the Contractor is an Equal Opportunity Employer, and that the Contractor will take affirmative action to ensure that applicants are employed, and that employees are treated during employment, without regard to their race, color, religion, sex, or national origin.
 - 1. Refer to further requirements as specified in the General Conditions.
- D. Project Superintendent: The Contractor will employ a qualified Superintendent, to run the project, with at least four (4) years previous experience as a Superintendent. The Superintendent shall not be removed or transferred from the project by the Contractor without prior approval of the Engineer. The Engineer reserves the right to request the removal of the Superintendent or any employee, subcontractor, etc. if in his judgment it is in the best interest of the Owner and the Project.

- E. Specifications: It is understood that reference to Specifications shall be sufficient to make the terms of such Specifications binding on the Contractor. The use of the name of a manufacturer, or any special brand or make in describing an item does not restrict the Bidder to that manufacturer or specific article, unless specifically stated, this means being used simply to indicate the character or quality of the article desired; but the articles on which the proposals are submitted must be equal to that specified.
- F. Officials Not to Benefit: No commissioner, officer or employee elected or appointed by the Owner shall be interested, directly or indirectly, in any Contract or job for work or material or the profits thereof, or service to be furnished or performed for the Owner.
- G. Taxes: Successful Bidder will be responsible for all taxes levied under the laws of the State of Tennessee.
- H. Legal Residents: It shall be the Contractor's responsibility to ensure that all persons employed under this contract, whether directly or by subcontractor, be legal residents and authorized to work in the United States of America.
- I. Business Licenses: Determination of the need for local business licenses will be the responsibility of the successful bidder. The business license office may be reached at (901) 545-4249.

END OF SECTION 00 21 13

SECTION 00 41 43 – PROPOSAL FOR UNIT PRICE CONTRACT

Project: Town of Hollow Rock Seminary
Street Service Line Replacement

Date: _____

Project No. J-6746D

Proposal of _____, (hereinafter called "Bidder"), a corporation/
 partnership/individual.

To: Town of Hollow Rock (hereinafter called "Owner").

BID SCHEDULE

| Item No. | Description & Unit Price in Words | Quantity | Unit | Unit Price | Total Price |
|---------------------------|--|----------|------|------------|-------------|
| 1 | ¾" CTS Water Service Line Open Cut | 650 | LF | | |
| 2 | ¾" Water Service Line Replacement Directional Bore (contractor has option of using pull cable means in leu of directional bore). | 900 | LF | | |
| 3 | Asphalt | 10 | TON | | |
| 4 | Gravel | 30 | TON | | |
| 5 | Seed & Straw | 1 | LS | | |
| 6 | Traffic Control | 1 | LS | | |
| 7 | Mobilization | 1 | LS | | |
| Total Bid in Words | | | | | |
| _____ | | \$ | | | |
| _____ | | | | | |

Bidder acknowledges receipt of the following addendum(s):

1. _____ (date)
2. _____ (date)
3. _____ (date)

(Amounts are to be shown in both words and figures. In case of discrepancy, the amount shown in words will govern.)

The above unit prices shall include all labor, materials, bailing, shoring, removal, overhead, profit, insurance, etc., to cover the finished work of the several kinds called for.

Bidder understands that the Owner reserves the right to reject any or all bids and to waive any informalities in the bidding.

The bidder agrees that this bid shall be good and may not be withdrawn for a period of 60 days after the scheduled closing time for receiving bids.

Upon receipt of written notice of the acceptance of this bid, the bidder will execute the formal contract attached within 10 days and deliver a Surety Bond or Bonds as required by the General Conditions. The bid security attached in the sum of

(\$ _____) is to become the property of the Owner in the event the contract and bond are not executed within the time set forth above, as liquidated damages for the delay and additional expense to the Owner caused thereby.

Respectfully submitted:

By: _____
(Signature)

(Title)

(Business Address & Zip Code)

(SEAL - if bid is by a corporation)

END OF SECTION 00 41 43

SECTION 00 43 13- BID BOND

KNOW ALL MEN BY THESE PRESENTS, that we, the undersigned, _____, as Principal, and, _____ as Surety, are hereby held and firmly bound unto the Town of Hollow Rock as OWNER, in the penal sum of _____ for the payment of which, well and truly to be made, we hereby jointly and severally bind ourselves, successors and assigns.

Signed, this the _____ day of _____, 20_____.

The Condition of the above obligation is such that whereas the Principal has submitted to _____ a certain Bid, attached hereto and hereby made a part hereof to enter into a contract in writing for the Town of Hollow Rock.

NOW, THEREFORE,

- (a) If said Bid shall be rejected, or
- (b) If said Bid shall be accepted and the Principal shall execute and deliver a contract in the Form of Contract attached hereto (properly completed in accordance with said Bid) and shall furnish a Bond for his faithful performance of said contract, and for the payment of all persons performing labor or furnishing materials in connection therewith, and shall in all other respects perform the agreement created by the acceptance of said Bid, then this obligation shall be void, otherwise the same shall remain in force and effect; it being expressly understood and agreed that the liability of the Surety for any and all claims hereunder shall, in no event, exceed the penal amount of this obligation as herein stated.

The Surety, for value received, hereby stipulates, and agrees that the obligations of said Surety and its Bond shall be in no way impaired or affected by any extension of the time within which the OWNER may accept such Bid; and said Surety does hereby waive notice of any such extension.

IN WITNESS WHEREOF, the Principal and the Surety have hereunto set their hands and seals, and such of them as are corporations have caused their corporate seals to be hereto affixed and these presents to be signed by their proper officers, the day and year first set forth above.

Principal

Surety

By: _____

SECTION 00 45 49- DRUG-FREE AFFIDAVIT

STATE OF: TENNESSEE
COUNTY OF:

The undersigned, Principal Officer of _____, an employer of five (5) or more employees contracting with the Town of Hollow Rock, Tennessee, government to provide construction services, hereby states under oath as follows:

1. The undersigned is a principal officer of _____ (hereinafter referred to as the "Company") and is duly authorized to execute this Affidavit on behalf of the Company.
2. The Company submits this Affidavit pursuant to T.C.A. § 50-9-113, which requires each employer with no less than five (5) employees receiving pay who contracts with the state or any local government to provide construction services to submit an affidavit stating that such employer has a drug-free workplace program that complies with Title 50, Chapter 9, of the *Tennessee Code Annotated*.
3. The Company is in compliance with T.C.A. § 50-9-113.

Attached hereto is a true and correct copy of the Company's "Certificate of Compliance" (certified application) from the Tennessee Department of Labor and Workforce Development.

Further affiant saith not.

Principal Officer

STATE OF: TENNESSEE
COUNTY OF:

Before me personally appeared _____, with whom I am personally acquainted (or proved to me on the basis of satisfactory evidence), and who acknowledged that such person executed the foregoing affidavit for the purposes therein contained.

Witness my hand and seal at office this _____ day of _____, 20__.

_____ My commission expires: _____

Notary Public

Attach a copy of your certificate of compliance to this affidavit.

If your company has less than five (5) employees, sign below.

If less than five (5) employees sign here:

Principal

Title

END OF SECTION 00 45 49



STATE OF TENNESSEE

BYRD ANTI-LOBBYING AMENDMENT CERTIFICATION

Contractors who apply or bid for an award of \$100,000 or more shall file the required certification. Each tier certifies to the tier above that it will not and has not used Federal appropriated funds to pay any person or organization for influencing or attempting to influence an officer or employee of any agency, a Member of Congress, officer or employee of Congress, or an employee of a Member of Congress in connection with obtaining any Federal contract, grant, or any other award covered by 31 U.S.C. § 1352.

Each tier shall also disclose any lobbying with non-Federal funds that takes place in connection with obtaining any Federal award. Such disclosures are forwarded from tier to tier up to the recipient who in turn will forward the certification(s) to the awarding agency.

APPENDIX A, 44 C.F.R. PART 18 – CERTIFICATION REGARDING LOBBYING – REQUIRED FOR CONTRACTS OVER \$100,000 *Certification for Contracts, Grants, Loans, and Cooperative Agreements*

The undersigned certifies, to the best of his or her knowledge and belief, that:

- No Federal appropriated funds have been paid or will be paid, by or on behalf of the undersigned, to any person for influencing or attempting to influence an officer or employee of an agency, a Member of Congress, an officer or employee of Congress, or an employee of a Member of Congress in connection with the awarding of any Federal contract, the making of any Federal grant, the making of any Federal loan, the entering into of any cooperative agreement, and the extension, continuation, renewal, amendment, or modification of any Federal contract, grant, loan, or cooperative agreement.
- If any funds other than Federal appropriated funds have been paid or will be paid to any person for influencing or attempting to influence an officer or employee of any agency, a Member of Congress, an officer or employee of Congress, or an employee of a Member of Congress in connection with this Federal contract, grant, loan, or cooperative agreement, the undersigned shall complete and submit Standard Form-LLL, "Disclosure Form to Report Lobbying," in accordance with its instructions.
- The undersigned shall require that the language of this certification be included in the award documents for all subawards at all tiers (including subcontracts, subgrants, and contracts under grants, loans, and cooperative agreements) and that all subrecipients shall certify and disclose accordingly.

This certification is a material representation of fact upon which reliance was placed when this transaction was made or entered into. Submission of this certification is a prerequisite for making or entering into this transaction imposed by section 1352, title 31, U.S. Code. Any person who fails to file the required certification shall be subject to a civil penalty of not less than \$10,000 and not more than \$100,000 for each such failure.

The Contractor certifies or affirms the truthfulness and accuracy of each statement of its certification and disclosure, if any. In addition, the Contractor understands and agrees that the provisions of 31 U.S.C. Chap. 38, Administrative Remedies for False Claims and Statements, apply to this certification and disclosure, if any.

| | |
|---|-------------------------------------|
| | |
| Signature of Authorized Representative | Date |
| | |
| Printed Name and Title | Phone Number / Email Address |



STATE OF TENNESSEE
IRAN DIVESTMENT ACT CERTIFICATION

| | |
|---|--|
| SUBJECT CONTRACT NUMBER(S): | |
| CONTRACTOR LEGAL ENTITY NAME: | |
| EDISON SUPPLIER IDENTIFICATION NUMBER: | |

The Iran Divestment Act, Tenn. Code Ann. § 12-12-101 et. seq. requires a person that attempts to contract with the state, including a contract renewal or assumption, to certify at the time the bid is submitted or the contract is entered into, renewed, or assigned, that the person or the assignee is not identified on a list created pursuant to § 12-12-106.

Currently, the list is available online at the following website: <https://www.tn.gov/generalservices/procurement/central-procurement-office--cpo-/library-/public-information-library.html>

The Contractor, identified above, certifies by signature below that it is not included on the list of persons created pursuant to Tenn. Code Ann. § 12-12-106 of the Iran Divestment Act.

CONTRACTOR SIGNATURE

NOTICE: This certification MUST be signed by an individual with legal capacity to contractually bind the Contractor.

PRINTED NAME AND TITLE OF SIGNATORY

DATE



STATE OF TENNESSEE
CERTIFICATION REGARDING DEBARMENT, SUSPENSION
AND OTHER RESPONSIBILITY MATTERS

The prospective participant certifies to the best of its knowledge and belief that it and its principals:

- Are not presently debarred, suspended, proposed for debarment, declared ineligible, or voluntarily excluded from covered transactions by any Federal department or agency;
- Have not within a three-year period preceding this proposal been convicted of or had a civil judgement rendered against them for commission of fraud or a criminal offense in connection with obtaining, attempting to obtain, or performing a public (Federal, State, or local) transaction or contract under a public transaction; violation of Federal or State antitrust statutes or commission of embezzlement, theft, forgery, bribery, falsification or destruction of records, making false statements, or receiving stolen property;
- Are not presently indicted for or otherwise criminally or civilly charged by a government entity (Federal, State, or local) with commission of any of the offenses enumerated in paragraph (b) of this certification; and
- Have not within a three-year period preceding this application/proposal had one or more public transactions (Federal, State, or local) terminated for cause or default.

I understand that a false statement on this certification may be grounds for rejection of this proposal or termination of the award. In addition, under 18 USC Sec. 1001, a false statement may result in a fine of up to \$10,000 or imprisonment for up to 5 years, or both.

| | |
|---|-------------------------------------|
| | |
| Signature of Authorized Representative | Date |
| | |
| Printed Name | Phone Number / Email Address |

I am unable to certify to the above statements. Explanation is attached.



STATE OF TENNESSEE
NON-BOYCOTT OF ISRAEL CERTIFICATION

The Bidder certifies that it is not currently engaged in, and will not for the duration of the contract engage in, a boycott of Israel as defined by Tenn. Code Ann. § 12-4-119. This provision shall not apply to contracts with a total value of less than two hundred fifty thousand dollars (\$250,000) or to contractors with less than ten (10) employees.

According to the law, a boycott of Israel means engaging in refusals to deal, terminating business activities, or other commercial actions that are intended to limit commercial relations with Israel, or companies doing business in or with Israel or authorized by, licensed by, or organized under the laws of the State of Israel to do business, or persons or entities doing business in Israel, when such actions are taken:

- 1) In compliance with, or adherence to, calls for a boycott of Israel, or
- 2) In a manner that discriminates on the basis of nationality, national origin, religion, or other unreasonable basis, and is not based on a valid business reason. Tenn. Code Ann. § 12-4-119.

| | |
|---|-------------------------------------|
| | |
| Signature of Authorized Representative | Date |
| | |
| Printed Name | Phone Number / Email Address |

**CERTIFICATION BY PROPOSED PRIME OR SUBCONTRACTOR REGARDING
EQUAL EMPLOYMENT OPPORTUNITY**

Name of Prime Contractor

Project Number

INSTRUCTIONS

This certification is required pursuant to Executive Order 11246, Part II, Section 203 (b), 30 F.R. 12319-25). Any bidder or prospective contractor, or any of their proposed subcontractors, shall state as an initial part of the bid or negotiations of the contract whether it has participated in any previous contract or subcontract subject to the equal opportunity clause; and, if so, whether it has filed all compliance reports due under applicable instructions.

Where the certification indicated that the prime or subcontractor has not filed a compliance report due under applicable instruction, such contractor shall be required to submit a compliance report.

CONTRACTOR'S CERTIFICATION

Contractor's Name: _____

Address: _____

1. Bidder has participated in a previous contract or subcontract subject to the Equal Opportunity Clause. Yes No
2. Compliance Reports were required to be filed in connection with such contract or subcontract. Yes No

If yes, state what reports were filed and with what agency.

3. Bidder has filed all compliance reports due under applicable instructions, including SF-100. Yes No
4. If answer to Item 3 is NO, please explain in detail on reverse side of this certification.

Certification - The information above is true and complete to the best of my knowledge and belief. (A willfully false statement is punishable by law-U.S. Code, Title 18, Section 1001.)

Name and title of signer (Please type)

Signature

Date

ACKNOWLEDGEMENT REGARDING BIDDER SAM REGISTRATION

Pursuant to 2 CFR Parts 183 and 215 and the requirement of the U.S. Department of Housing and Urban Development (HUD), contractors procured directly by grantees, sub-grantees, and/or sub-recipients of HUD funds, including CDBG are required to have an active registration in the System of Award Management (SAM). This document shall be completed and submitted as part of the bid proposal.

1. By submitting this proposal, the prospective bidder certifies that it has an active registration in SAM that is not set to expire within the next 90 days.
2. By submitting this proposal, the prospective bidder certifies neither it, its principals nor affiliates, is presently debarred, suspended, proposed for debarment, declared ineligible, or voluntarily excluded from participation in this transaction by any Federal department or agency.
3. The certification in this clause is a material representation of fact upon which reliance was placed when this transaction was entered into. If it is later determined that an erroneous certification was rendered, in addition to other remedies available to the Federal Government, the Department or agency with which this transaction originated may pursue available remedies.
4. Further, the prospective bidder shall provide immediate written notice to the person to which this proposal is submitted if at any time the Participant learns that this certification was erroneous when submitted or has become erroneous by reason of changed circumstances.
5. By submitting this proposal, it is agreed that should the proposed covered transaction be entered into, the prospective bidder will not knowingly enter into any lower-tier covered transaction with a person who is debarred, suspended, declared ineligible, or voluntarily excluded from participation in this covered transaction unless authorized by the agency with which this transaction originated.
6. It is further agreed that by submitting this proposal, the prospective bidder will include Certification of Subcontractor Regarding Debarment, Suspension, Ineligibility and Voluntary Exclusion without modification, in all lower-tier covered transactions and in all solicitations for lower-tier covered transactions.

Provide the following information as detailed in the prospective bidder's SAM registration:

Entity Name: _____

Address: _____

City: _____ State: _____ Zip: _____

SAM Entity ID: _____ Expiration Date: _____

Active Exclusions: Yes No



**TENNESSEE DEPARTMENT OF ENVIRONMENT AND CONSERVATION
RECREATION EDUCATIONAL SERVICES**

WR Snodgrass TN Tower, 312 Rosa L. Parks Avenue, 2nd Floor, Nashville, TN 37243
PH: 615-532-0748 FAX: 615-532-0732

**CERTIFICATION OF CONTRACTOR
REGARDING CONFLICTS OF INTEREST,
LOBBYING, NONDISCRIMINATION, PUBLIC ACCOUNTABILITY,
AND PUBLIC NOTICE**

This certification is required by the agency that has funded, in part, by: **(check one)**

- Local Park & Recreation Fund (LPRF)** **Land & Water Conservation Fund (LWCF)**
 Recreation Trail Program (RTP) **Other** ARP

The Contractor, _____, by signing and submitting this Certification, acknowledges the following: This Certification will be incorporated into the Agreement executed between: the Town of Hollow Rock (*the Grantee*) and the Contractor.

By signing and submitting this Certification, the Contractor certifies that neither it, its principals nor affiliates has violated the following:

1. **Conflicts of Interest:** The Grantee warrants that no part of the total Grant Contract Amount shall be paid directly or indirectly to an employee or official of the State of Tennessee as wages, compensation, or gifts in exchange for acting as an officer, agent, employee, subcontractor, or consultant to the Grantee in connection with any work contemplated or performed relative to this Grant Contract.
2. **Lobbying:** The Grantee certifies to the best of its knowledge and belief that:
 - a. No federally appropriated funds have been paid or will be paid, by or on behalf of the undersigned, to any person for influencing or attempting to influence an officer or employee of an agency, a Member of Congress, an officer or employee of Congress, or an employee of a Member of Congress in connection with the awarding of any federal contract, the making of any federal grant, the making of any federal loan, the entering into of any cooperative agreement, and the extension, continuation, renewal, amendment, or modification of any federal contract, grant, loan, or cooperative agreement.
 - b. If any funds other than federally appropriated funds have been paid or will be paid to any person for influencing or attempting to influence an officer or employee of any agency, a Member of Congress, an officer or employee of Congress, or an employee of a Member of Congress in connection with this contract, grant, loan, or cooperative agreement, the Grantee shall complete and submit Standard Form-LLL, "Disclosure of Lobbying Activities," in accordance with its instructions.
 - c. The Grantee shall require that the language of this certification be included in the award documents for all sub-awards at all tiers (including subcontracts, sub-grants, and contracts under grants, loans, and cooperative agreements) and that all sub-recipients shall certify and disclose accordingly.

This certification is a material representation of fact upon which reliance was placed when this transaction was made or entered into and is a prerequisite for making or entering into this transaction imposed by 31 U.S.C. § 1352.

3. **Nondiscrimination:** The Grantee hereby agrees, warrants, and assures that no person shall be excluded from participation in, be denied benefits of, or be otherwise subjected to discrimination in the performance of this Grant Contract or in the employment practices of the Grantee on the grounds of handicap or disability, age, race, color,

religion, sex, national origin, or any other classification protected by federal, Tennessee state constitutional, or statutory law. The Grantee shall, upon request, show proof of nondiscrimination and shall post in conspicuous places, available to all employees and applicants, notices of nondiscrimination.

4. Public Accountability: If the Grantee is subject to Tenn. Code Ann. § 8-4-401 *et seq.*, or if this Grant Contract involves the provision of services to citizens by the Grantee on behalf of the State, the Grantee agrees to establish a system through which recipients of services may present grievances about the operation of the service program. The Grantee shall also display in a prominent place, located near the passageway through which the public enters in order to receive Grant supported services, a sign at least eleven inches (11") in height and seventeen inches (17") in width stating:

NOTICE: THIS AGENCY IS A RECIPIENT OF TAXPAYER FUNDING. IF YOU OBSERVE AN AGENCY DIRECTOR OR EMPLOYEE ENGAGING IN ANY ACTIVITY WHICH YOU CONSIDER TO BE ILLEGAL, IMPROPER, OR WASTEFUL, PLEASE CALL THE STATE COMPTROLLER'S TOLL-FREE HOTLINE: 1-800-232-5454.

The sign shall be on the form prescribed by the Comptroller of the Treasury. The Grantor State Agency shall obtain copies of the sign from the Comptroller of the Treasury, and upon request from the Grantee, provide Grantee with any necessary signs.

5. Public Notice: All notices, informational pamphlets, press releases, research reports, signs, and similar public notices prepared and released by the Grantee in relation to this Grant Contract shall include the statement, "This project is funded under a grant contract with the State of Tennessee." All notices by the Grantee in relation to this Grant Contract shall be approved by the State.
6. Records: The Grantee and any approved subcontractor shall maintain documentation for all charges under this Grant Contract. The books, records, and documents of the Grantee and any approved subcontractor, insofar as they relate to work performed or money received under this Grant Contract, shall be maintained in accordance with applicable Tennessee law. In no case shall the records be maintained for a period of less than five (5) full years from the date of the final payment. The Grantee's records shall be subject to audit at any reasonable time and upon reasonable notice by the Grantor State Agency, the Comptroller of the Treasury, or their duly appointed representatives.

The records shall be maintained in accordance with Governmental Accounting Standards Board (GASB) Accounting Standards or the Financial Accounting Standards Board (FASB) Accounting Standards Codification, as applicable, and any related AICPA Industry Audit and Accounting guides.

In addition, documentation of grant applications, budgets, reports, awards, and expenditures will be maintained in accordance with U.S. Office of Management and Budget's Uniform Administrative Requirements, Cost Principles, and Audit Requirements for Federal Awards.

Grant expenditures shall be made in accordance with local government purchasing policies and procedures and purchasing procedures for local governments authorized under state law.

The Grantee shall also comply with any recordkeeping and reporting requirements prescribed by the Tennessee Comptroller of the Treasury.

The Grantee shall establish a system of internal controls that utilize the COSO Internal Control - Integrated Framework model as the basic foundation for the internal control system. The Grantee shall incorporate any additional Comptroller of the Treasury directives into its internal control system.

Any other required records or reports which are not contemplated in the above standards shall follow the format designated by the head of the Grantor State Agency, the Central Procurement Office, or the Commissioner of Finance and Administration of the State of Tennessee.

**Grantee's Authorized Representative:
(USUALLY MAYOR)**

Signature

Robert Brotherton

Print Name

Mayor

Title

Date

CONTRACTOR: _____

Signature

Print Name

Title

Date

NOTICE

THIS ENTITY IS A RECIPIENT OF **STATE AND FEDERAL** FUNDS. IF YOU HAVE KNOWLEDGE OF ANY ACTIVITY WHICH YOU CONSIDER TO BE ILLEGAL, IMPROPER, OR WASTEFUL, PLEASE CALL THE STATE COMPTROLLER'S TOLL-FREE HOTLINE:

1-800-232-5454



STATE WATER INFRASTRUCTURE GRANTS

IDENTIFICATION SIGN

All plans and specifications for each project approved shall contain provisions for requiring the general contractor to provide identification signs. The signs shall conform to the following basic features:

1. The following diagram shall be used as a design:

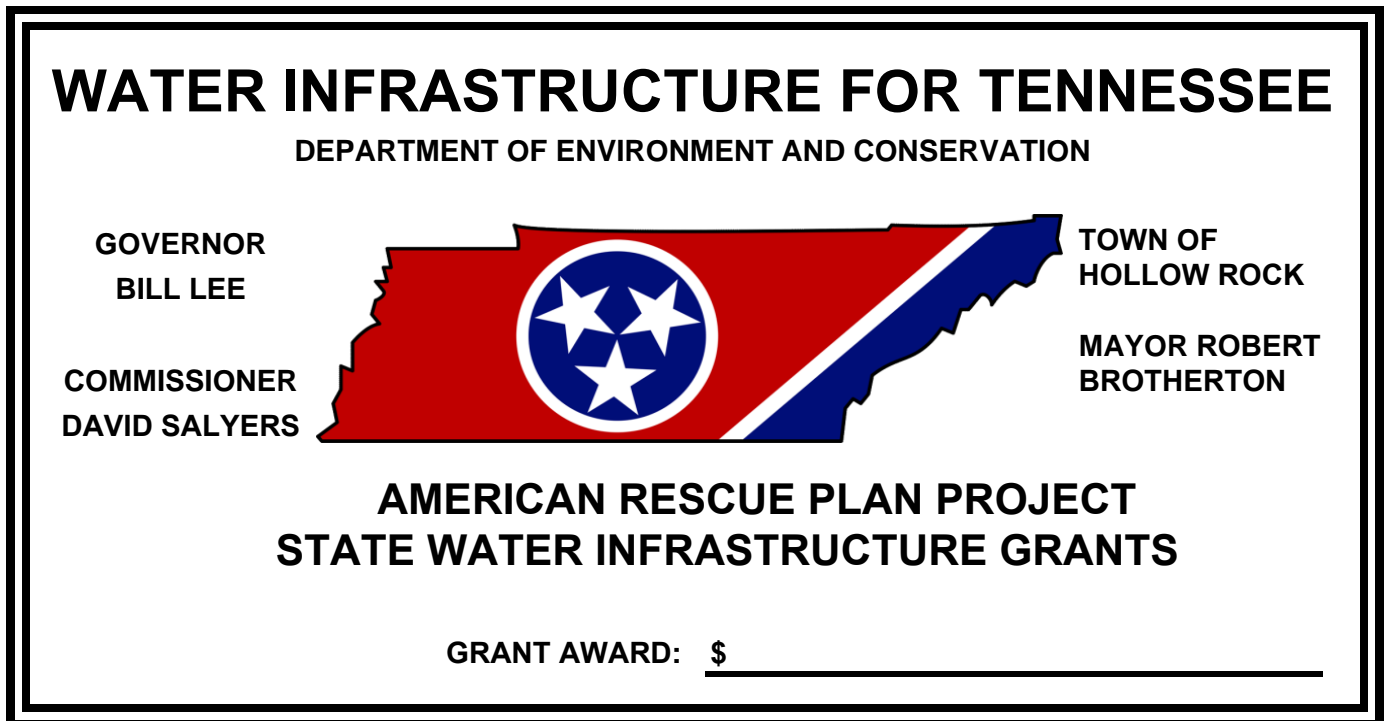

2. The sign shall be a 4'0" X 8'0" sheet of exterior grade plywood and shall be built so as to remain erected during the entire construction phase of the project.
3. The background of both sides shall be white. The lettering shall be black and shall be large enough to take advantage of the full size of the plywood. The stars shall be white set on a blue field and surrounded by a white ring placed inside a state map in red with a stripe of white and blue on the right side. The sign shall be bordered by a one-inch blue stripe.

SECTION 00 51 00- NOTICE OF AWARD

TO: _____

PROJECT DESCRIPTION: | Town of Hollow Rock Seminary Street Service Line Replacement

The Owner has considered the Bid submitted by you for the above-described Project in response to its Advertisement for Bid dated May 22, 2024, and Information for Bidders.

You are hereby notified that your Bid has been accepted for items in the amount of: \$_____,
_____.

You are required by the Information for Bidders to execute the Agreement and furnish the required Contractor's Performance Bond, Payment Bond, and Certificates of Insurance within ten (10) calendar days from the date of this Notice to you. Failure to execute said Agreement and/or to furnish said Bonds in the time allotted will entitle the Owner to consider all your rights arising out of the Owner's acceptance of your Bid as abandoned and as a forfeiture of your Bid Bond. The Owner will be entitled to such other rights as may be granted by law.

You are required to return an acknowledged copy of this Notice of Award to the Owner dated this _____ day of _____.

Owner: _____ Town of Hollow Rock _____

Signed: _____

By: _____ Robert Brotherton _____

Title: _____ Mayor _____

Issuance of a contract is contingent upon concurrence by any State and/or Federal funding agency. Should concurrence not be received this Notice of Award shall be withdrawn and no construction contract issued.

| | |
|---|-------|
| ACCEPTANCE OF NOTICE | |
| Receipt of the above Notice of Award is hereby acknowledged by: | |
| this, the _____ day of _____ | _____ |
| By: | _____ |
| Title: | _____ |

SECTION 00 52 00 - AGREEMENT

THIS AGREEMENT, made the _____ day of _____, 20____, by and between the Town of Hollow Rock, hereinafter called "OWNER" and _____, doing business as (an individual), or (a partnership), or (a corporation) hereinafter called "CONTRACTOR."

WITNESSETH: That for and in consideration of the payments and agreements hereinafter mentioned:

1. The CONTRACTOR will commence and complete the construction of the Town of Hollow Rock Seminary Street Service Line Replacement.
2. The CONTRACTOR will furnish all of the material, supplies, tools, equipment, labor, and other services necessary for the construction and completion of the PROJECT described herein.
3. The CONTRACTOR will commence the work required by the CONTRACT DOCUMENTS within 10 calendar days after the date of the NOTICE TO PROCEED and will complete the same within 90 calendar days unless the period for completion is extended otherwise by the CONTRACT DOCUMENTS.
4. The CONTRACTOR agrees to perform all of the WORK described in the CONTRACT DOCUMENTS and comply with the terms therein for the sum of _____
_____ (\$ _____) or as shown in the BID schedule.
5. The term "CONTRACT DOCUMENTS" means and includes the following:
 - a. Advertisement for Bids
 - b. Information for Bidders
 - c. Bid
 - d. Bid Bond
 - e. Agreement
 - f. General Conditions
 - g. Supplemental General Conditions
 - h. Payment Bond
 - i. Performance Bond
 - j. Notice of Award
 - k. Notice to Proceed
 - l. Change Order
 - m. Drawings prepared by _____, numbered _____ through _____, and dated _____.
 - n. Specifications prepared or issued by _____ and dated _____.
 - o. Addenda:
 - No. _____, dated _____, 20____
 - No. _____, dated _____, 20____
 - No. _____, dated _____, 20____

- 6. The OWNER will pay to the CONTRACTOR in the manner and at such times as set forth in the General Conditions such amounts as required by the CONTRACT DOCUMENTS.
- 7. This AGREEMENT shall be binding upon all parties hereto and their respective heirs, executors, administrators, successors, and assigns.

IN WITNESS WHEREOF, the parties hereto have executed, or caused to be executed by their duly authorized officials, this Agreement in quadruplicate (4 copies), each of which shall be deemed an original on the date first above written.

(SEAL)

CONTRACTOR:

ATTEST:

By:

Name:

Name:

(Please Type)

(Please Type)

(SEAL)

OWNER:

Town of Hollow Rock

ATTEST:

By:

Name:

Name:

Robert Brotherton, Mayor

END OF SECTION 00 52 00

SECTION 00 55 00 – NOTICE TO PROCEED

TO: _____

DATE: _____

PROJECT NAME: | Town of Hollow Rock Seminary Street
| Service Line Replacement

TLM PROJECT NO. J-6746D

You are hereby notified to commence work in accordance with the Agreement dated _____,
on or before _____, and you are to complete the work within 90 consecutive
calendar days thereafter.

The date of completion for all work, including clean-up, is therefore, _____.

Owner: _____ Town of Hollow Rock

Signed: _____

By: _____ Robert Brotherton

Title: _____ Mayor

ACCEPTANCE OF NOTICE

Receipt of the above NOTICE TO PROCEED is hereby
acknowledged by:

this, the _____ day of _____, 20

By: _____

Title: _____

SECTION 00 61 13.13- PERFORMANCE BOND

KNOW ALL MEN BY THESE PRESENTS: that

(Name of Contractor)

(Address of Contractor)

a (corporation / partnership / individual), hereinafter called PRINCIPAL, and

(Name of Surety)

(Address of Surety)

hereinafter called SURETY, are held and firmly bound unto:

Town of Hollow Rock
(Name of Owner)

27960 Broad St, Hollow Rock, TN 38342
(Address of Owner)

hereinafter called OWNER, in the penal sum of _____
(\$ _____) in lawful money of the United States, for the payment of which sum well and truly to be made, we bind ourselves, successors, and assigns, jointly and severally, firmly by these presents.

THE CONDITION OF THIS OBLIGATION is such that whereas, the Principal entered into a certain contract with the Owner, dated the _____ day of _____, 20___, a copy of which is hereto attached and made a part hereof for the construction of the Hollow Rock Seminary Street Service Line Replacement.

NOW, THEREFORE, if the Principal shall well, truly and faithfully perform its duties, all the undertakings, covenants, terms, conditions, and agreements of said contract during the original term thereof, and any extensions thereof which may be granted by the Owner, with or without notice to the Surety and during the one-year guaranty period, and if he shall satisfy all claims and demands incurred under such contract, and shall fully indemnify and save harmless the Owner from all costs and damages which it may suffer by reason of failure to do so, and shall reimburse and repay the Owner all outlay and expense which the Owner may incur in making good any default, then this obligation shall be void; otherwise to remain in full force and effect.

PROVIDED, FURTHER, that the said Surety, for value received hereby stipulates and agrees that no

change, extension of time, alteration or addition to the terms of the contract or to work to be performed thereunder or the Specifications accompanying the same shall in any wise affect its obligation on this Bond, and it does hereby waive notice of any such change, extension of time, alteration or addition to the terms of the Contract or to the work or to the Specifications.

PROVIDED, FURTHER, that no final settlement between the Owner and the Contractor shall abridge the right of any beneficiary hereunder, whose claim may be unsatisfied.

IN WITNESS WHEREOF, this instrument is executed in five (5) counterparts, each one of which shall be deemed an original, this the _____ day of _____, 20__.

ATTEST:

Principal

(Principal) Secretary

By: _____

(SEAL)

Address: _____

Witness as to Principal

Address

Surety

ATTEST:

By: _____

Surety (Secretary)

Attorney-in-Fact

(SEAL)

Address: _____

(Witness as to Surety)

Address

NOTE: Date of Bond must not be prior to date of Contract.

If Contractor is partnership, all partners should execute Bond.

IMPORTANT: Surety Company's executing Bonds must appear on the Treasury Department's most current list (Circular 570 as amended) and be authorized to transact business in the state where the Project is located.

END OF SECTION 00 61 13.13

SECTION 00 61 13.16- PAYMENT BOND

KNOW ALL MEN BY THESE PRESENTS: that

(Name of Contractor)

(Address of Contractor)

a (corporation / partnership / individual), hereinafter called PRINCIPAL, and

(Name of Surety)

(Address of Surety)

hereinafter called SURETY, are held and firmly bound unto:

Town of Hollow Rock
(Name of Owner)

27960 Broad St, Hollow Rock, TN 38342
(Address of Owner)

hereinafter called OWNER, in the penal sum of _____
(\$ _____) in lawful money of the United States, for the payment of which sum well and truly to be made, we bind ourselves, successors, and assigns, jointly and severally, firmly by these presents.

THE CONDITION OF THIS OBLIGATION is such that whereas, the Principal entered into a certain contract with the Owner, dated the _____ day of _____, 20__, a copy of which is hereto attached and made a part hereof for the Hollow Rock Seminary Street Service Line Replacement.

NOW, THEREFORE, if the Principal shall promptly make payment to all persons, firms, subcontractors, and corporations furnishing materials for or performing labor in the prosecution of the work provided for in such Contract, and any authorized extension or modification thereof, including all amounts due for materials, lubricants, oil, gasoline, coal and coke, repairs on machinery, equipment and tools, consumed or used in connection with the work whether by subcontractor or otherwise, then this obligation shall be void; otherwise to remain in full force and effect.

PROVIDED, FURTHER, that the said Surety, for value received hereby stipulates and agrees that no change, extension of time, alteration or addition to the terms of the contract or to work to be performed thereunder or the Specifications accompanying the same shall in any wise affect its obligation on this Bond, and it does hereby waive notice of any such change, extension of time, alteration or addition to the terms of the Contract or to the work or to the Specifications.

PROVIDED, FURTHER, that no final settlement between the Owner and the Contractor shall abridge the right of any beneficiary hereunder, whose claim may be unsatisfied.

IN WITNESS WHEREOF, this instrument is executed in five (5) counterparts, each one of which shall be deemed an original, this the _____ day of _____, 20__.

ATTEST:

| | |
|--------------------------------|-------------------------|
| _____ | _____ |
| <i>(Principal) Secretary</i> | <i>Principal</i> |
| (SEAL) | By: _____ |
| _____ | Address: _____ |
| <i>Witness as to Principal</i> | _____ |
| _____ | _____ |
| <i>Address</i> | <i>Surety</i> |
| _____ | By: _____ |
| ATTEST: | <i>Attorney-in-Fact</i> |
| _____ | Address: _____ |
| <i>Surety (Secretary)</i> | _____ |
| (SEAL) | _____ |
| _____ | _____ |
| <i>(Witness as to Surety)</i> | |
| _____ | |
| <i>Address</i> | |
| _____ | |

NOTE: Date of BOND must not be prior to date of Contract.

If Contractor is partnership, all partners should execute BOND.

IMPORTANT: Surety Company's executing BONDS must appear on the Treasury Department's most current list (Circular 570 as amended) and be authorized to transact business in the state where the Project is located.

SECTION 00 61 00- BONDS AND CERTIFICATES

INSURANCE CERTIFICATES

- This Attachment sets forth bonding and insurance requirements for grants. No other bonding and insurance requirements shall be imposed other than those normally required by the grantee.
- Except as otherwise required by law, a grant that requires the contracting (or subcontracting) for construction or facility improvements shall provide for the grantee to follow its own requirements relating to bid guarantees, performance bonds, and payment bonds unless the construction contract or subcontract exceeds \$150,000 (See 2 CFR 200.88). For those contracts or subcontracts exceeding \$150,000, the Federal agency may accept the bonding policy and requirements of the grantee provided the Federal agency has decided that the Government's interest is adequately protected. If such a determination has not been made, the minimum requirements shall be as follows:
 - A bid guarantee from each bidder equivalent to five percent of the bid price. The "bid guarantee" shall consist of a firm commitment such as a bid bond, certified check, or other negotiable instrument accompanying a bid as assurance that the bidder will, upon acceptance of his bid, execute such contractual documents as may be required within the time specified.
 - A performance bond on the part of the contractor for 100 percent of the contract price. A "performance bond" is one executed in connection with a contract to secure fulfillment of all the contractor's obligations under such contract.
 - A payment bond on the part of the contractor for 100 percent of the contract price. A "payment bond" is one executed in connection with a contract to assure payment as required by law of all persons supplying labor and material in the execution of the work provided for in the contract.
- Where the Federal Government guarantees or insures the repayment of money borrowed by the grantee, the Federal agency, at its discretion, may require adequate bonding and insurance if the bonding and insurance requirements of the grantee are not deemed adequate to protect the interest of the Federal Government.
- Where bonds are required in the situations described above, the bonds shall be obtained from companies holding certificates of authority as acceptable sureties (31 CFR 223).
- Contractor shall submit insurance certificates as applicable.
- Insurance shall list Owner and Engineer as additionally insured.

NOTE: AIA Document A311 is acceptable for use as Performance and Payment Bonds.

SECTION 00 72 00 – GENERAL CONDITIONS

The "General Conditions of the Contract for Construction," Document EJCDC C-700, prepared by the Engineer's Joint Contract Documents Committee, dated 2013, Articles 1 through 18, Pages 1 through 67, is hereby made a part of the specification.

This document has important legal consequences; consultation with an attorney is encouraged with respect to its use or modification. This document should be adapted to the particular circumstances of the contemplated Project and the controlling Laws and Regulations.

STANDARD GENERAL CONDITIONS OF THE CONSTRUCTION CONTRACT

Prepared by



Issued and Published Jointly by



Endorsed by



These General Conditions have been prepared for use with the Agreement Between Owner and Contractor for Construction Contract (EJCDC® C-520, Stipulated Sum, or C-525, Cost-Plus, 2013 Editions). Their provisions are interrelated and a change in one may necessitate a change in the other.

To prepare supplementary conditions that are coordinated with the General Conditions, use EJCDC's Guide to the Preparation of Supplementary Conditions (EJCDC® C-800, 2013 Edition). The full EJCDC Construction series of documents is discussed in the Commentary on the 2013 EJCDC Construction Documents (EJCDC® C-001, 2013 Edition).

Copyright © 2013:

National Society of Professional Engineers
1420 King Street, Alexandria, VA 22314-2794
(703) 684-2882
www.nspe.org

American Council of Engineering Companies
1015 15th Street N.W., Washington, DC 20005
(202) 347-7474
www.acec.org

American Society of Civil Engineers
1801 Alexander Bell Drive, Reston, VA 20191-4400
(800) 548-2723
www.asce.org

The copyright for this document is owned jointly by the three sponsoring organizations listed above. The National Society of Professional Engineers is the Copyright Administrator for the EJCDC documents; please direct all inquiries regarding EJCDC copyrights to NSPE.

NOTE: EJCDC publications may be purchased at www.ejcdc.org, or from any of the sponsoring organizations above.

STANDARD GENERAL CONDITIONS OF THE CONSTRUCTION CONTRACT

TABLE OF CONTENTS

| | Page |
|--|-------------|
| Article 1 – Definitions and Terminology | 1 |
| 1.01 Defined Terms | 1 |
| 1.02 Terminology | 5 |
| Article 2 – Preliminary Matters | 6 |
| 2.01 Delivery of Bonds and Evidence of Insurance | 6 |
| 2.02 Copies of Documents | 6 |
| 2.03 Before Starting Construction | 6 |
| 2.04 Preconstruction Conference; Designation of Authorized Representatives | 7 |
| 2.05 Initial Acceptance of Schedules | 7 |
| 2.06 Electronic Transmittals | 7 |
| Article 3 – Documents: Intent, Requirements, Reuse | 8 |
| 3.01 Intent | 8 |
| 3.02 Reference Standards | 8 |
| 3.03 Reporting and Resolving Discrepancies | 8 |
| 3.04 Requirements of the Contract Documents | 9 |
| 3.05 Reuse of Documents | 10 |
| Article 4 – Commencement and Progress of the Work | 10 |
| 4.01 Commencement of Contract Times; Notice to Proceed | 10 |
| 4.02 Starting the Work | 10 |
| 4.03 Reference Points | 10 |
| 4.04 Progress Schedule | 10 |
| 4.05 Delays in Contractor’s Progress | 11 |
| Article 5 – Availability of Lands; Subsurface and Physical Conditions; Hazardous Environmental Conditions | 12 |
| 5.01 Availability of Lands | 12 |
| 5.02 Use of Site and Other Areas | 12 |
| 5.03 Subsurface and Physical Conditions | 13 |
| 5.04 Differing Subsurface or Physical Conditions | 14 |
| 5.05 Underground Facilities | 15 |

| | | |
|---|--|----|
| 5.06 | Hazardous Environmental Conditions at Site | 17 |
| Article 6 – Bonds and Insurance | | 19 |
| 6.01 | Performance, Payment, and Other Bonds | 19 |
| 6.02 | Insurance—General Provisions | 19 |
| 6.03 | Contractor’s Insurance | 20 |
| 6.04 | Owner’s Liability Insurance | 23 |
| 6.05 | Property Insurance | 23 |
| 6.06 | Waiver of Rights | 25 |
| 6.07 | Receipt and Application of Property Insurance Proceeds | 25 |
| Article 7 – Contractor’s Responsibilities | | 26 |
| 7.01 | Supervision and Superintendence | 26 |
| 7.02 | Labor; Working Hours | 26 |
| 7.03 | Services, Materials, and Equipment..... | 26 |
| 7.04 | “Or Equals” | 27 |
| 7.05 | Substitutes | 28 |
| 7.06 | Concerning Subcontractors, Suppliers, and Others | 29 |
| 7.07 | Patent Fees and Royalties | 31 |
| 7.08 | Permits | 31 |
| 7.09 | Taxes | 32 |
| 7.10 | Laws and Regulations..... | 32 |
| 7.11 | Record Documents | 32 |
| 7.12 | Safety and Protection..... | 32 |
| 7.13 | Safety Representative | 33 |
| 7.14 | Hazard Communication Programs | 33 |
| 7.15 | Emergencies | 34 |
| 7.16 | Shop Drawings, Samples, and Other Submittals..... | 34 |
| 7.17 | Contractor’s General Warranty and Guarantee..... | 36 |
| 7.18 | Indemnification | 37 |
| 7.19 | Delegation of Professional Design Services | 37 |
| Article 8 – Other Work at the Site | | 38 |
| 8.01 | Other Work | 38 |
| 8.02 | Coordination | 39 |
| 8.03 | Legal Relationships..... | 39 |

| | |
|--|----|
| Article 9 – Owner’s Responsibilities..... | 40 |
| 9.01 Communications to Contractor..... | 40 |
| 9.02 Replacement of Engineer | 40 |
| 9.03 Furnish Data | 40 |
| 9.04 Pay When Due..... | 40 |
| 9.05 Lands and Easements; Reports, Tests, and Drawings | 40 |
| 9.06 Insurance | 40 |
| 9.07 Change Orders..... | 40 |
| 9.08 Inspections, Tests, and Approvals..... | 41 |
| 9.09 Limitations on Owner’s Responsibilities | 41 |
| 9.10 Undisclosed Hazardous Environmental Condition..... | 41 |
| 9.11 Evidence of Financial Arrangements..... | 41 |
| 9.12 Safety Programs | 41 |
| Article 10 – Engineer’s Status During Construction..... | 41 |
| 10.01 Owner’s Representative..... | 41 |
| 10.02 Visits to Site..... | 41 |
| 10.03 Project Representative..... | 42 |
| 10.04 Rejecting Defective Work..... | 42 |
| 10.05 Shop Drawings, Change Orders and Payments..... | 42 |
| 10.06 Determinations for Unit Price Work | 42 |
| 10.07 Decisions on Requirements of Contract Documents and Acceptability of Work | 42 |
| 10.08 Limitations on Engineer’s Authority and Responsibilities..... | 42 |
| 10.09 Compliance with Safety Program..... | 43 |
| Article 11 – Amending the Contract Documents; Changes in the Work | 43 |
| 11.01 Amending and Supplementing Contract Documents | 43 |
| 11.02 Owner-Authorized Changes in the Work | 44 |
| 11.03 Unauthorized Changes in the Work | 44 |
| 11.04 Change of Contract Price | 44 |
| 11.05 Change of Contract Times | 45 |
| 11.06 Change Proposals | 45 |
| 11.07 Execution of Change Orders..... | 46 |
| 11.08 Notification to Surety..... | 47 |
| Article 12 – Claims..... | 47 |

| | | |
|--------------|---|----|
| 12.01 | Claims | 47 |
| Article 13 – | Cost of the Work; Allowances; Unit Price Work..... | 48 |
| 13.01 | Cost of the Work | 48 |
| 13.02 | Allowances | 50 |
| 13.03 | Unit Price Work | 51 |
| Article 14 – | Tests and Inspections; Correction, Removal or Acceptance of Defective Work..... | 52 |
| 14.01 | Access to Work..... | 52 |
| 14.02 | Tests, Inspections, and Approvals..... | 52 |
| 14.03 | Defective Work..... | 53 |
| 14.04 | Acceptance of Defective Work..... | 53 |
| 14.05 | Uncovering Work | 53 |
| 14.06 | Owner May Stop the Work | 54 |
| 14.07 | Owner May Correct Defective Work..... | 54 |
| Article 15 – | Payments to Contractor; Set-Offs; Completion; Correction Period | 55 |
| 15.01 | Progress Payments..... | 55 |
| 15.02 | Contractor’s Warranty of Title | 58 |
| 15.03 | Substantial Completion..... | 58 |
| 15.04 | Partial Use or Occupancy | 59 |
| 15.05 | Final Inspection | 59 |
| 15.06 | Final Payment..... | 59 |
| 15.07 | Waiver of Claims | 61 |
| 15.08 | Correction Period | 61 |
| Article 16 – | Suspension of Work and Termination | 62 |
| 16.01 | Owner May Suspend Work | 62 |
| 16.02 | Owner May Terminate for Cause | 62 |
| 16.03 | Owner May Terminate For Convenience | 63 |
| 16.04 | Contractor May Stop Work or Terminate | 63 |
| Article 17 – | Final Resolution of Disputes | 64 |
| 17.01 | Methods and Procedures..... | 64 |
| Article 18 – | Miscellaneous | 64 |
| 18.01 | Giving Notice | 64 |
| 18.02 | Computation of Times..... | 64 |
| 18.03 | Cumulative Remedies | 64 |

| | | |
|-------|-------------------------------|----|
| 18.04 | Limitation of Damages | 65 |
| 18.05 | No Waiver | 65 |
| 18.06 | Survival of Obligations | 65 |
| 18.07 | Controlling Law | 65 |
| 18.08 | Headings..... | 65 |

ARTICLE 1 – DEFINITIONS AND TERMINOLOGY

1.01 *Defined Terms*

- A. Wherever used in the Bidding Requirements or Contract Documents, a term printed with initial capital letters, including the term's singular and plural forms, will have the meaning indicated in the definitions below. In addition to terms specifically defined, terms with initial capital letters in the Contract Documents include references to identified articles and paragraphs, and the titles of other documents or forms.
1. *Addenda*—Written or graphic instruments issued prior to the opening of Bids which clarify, correct, or change the Bidding Requirements or the proposed Contract Documents.
 2. *Agreement*—The written instrument, executed by Owner and Contractor, that sets forth the Contract Price and Contract Times, identifies the parties and the Engineer, and designates the specific items that are Contract Documents.
 3. *Application for Payment*—The form acceptable to Engineer which is to be used by Contractor during the course of the Work in requesting progress or final payments and which is to be accompanied by such supporting documentation as is required by the Contract Documents.
 4. *Bid*—The offer of a Bidder submitted on the prescribed form setting forth the prices for the Work to be performed.
 5. *Bidder*—An individual or entity that submits a Bid to Owner.
 6. *Bidding Documents*—The Bidding Requirements, the proposed Contract Documents, and all Addenda.
 7. *Bidding Requirements*—The advertisement or invitation to bid, Instructions to Bidders, Bid Bond or other Bid security, if any, the Bid Form, and the Bid with any attachments.
 8. *Change Order*—A document which is signed by Contractor and Owner and authorizes an addition, deletion, or revision in the Work or an adjustment in the Contract Price or the Contract Times, or other revision to the Contract, issued on or after the Effective Date of the Contract.
 9. *Change Proposal*—A written request by Contractor, duly submitted in compliance with the procedural requirements set forth herein, seeking an adjustment in Contract Price or Contract Times, or both; contesting an initial decision by Engineer concerning the requirements of the Contract Documents or the acceptability of Work under the Contract Documents; challenging a set-off against payments due; or seeking other relief with respect to the terms of the Contract.
 10. *Claim*—(a) A demand or assertion by Owner directly to Contractor, duly submitted in compliance with the procedural requirements set forth herein: seeking an adjustment of Contract Price or Contract Times, or both; contesting an initial decision by Engineer concerning the requirements of the Contract Documents or the acceptability of Work under the Contract Documents; contesting Engineer's decision regarding a Change Proposal; seeking resolution of a contractual issue that Engineer has declined to address; or seeking other relief with respect to the terms of the Contract; or (b) a demand or assertion by Contractor directly to Owner, duly submitted in compliance with the procedural requirements set forth herein, contesting Engineer's decision regarding a Change Proposal; or seeking resolution of a contractual issue that Engineer

has declined to address. A demand for money or services by a third party is not a Claim.

11. *Constituent of Concern*—Asbestos, petroleum, radioactive materials, polychlorinated biphenyls (PCBs), hazardous waste, and any substance, product, waste, or other material of any nature whatsoever that is or becomes listed, regulated, or addressed pursuant to (a) the Comprehensive Environmental Response, Compensation and Liability Act, 42 U.S.C. §§9601 et seq. (“CERCLA”); (b) the Hazardous Materials Transportation Act, 49 U.S.C. §§5101 et seq.; (c) the Resource Conservation and Recovery Act, 42 U.S.C. §§6901 et seq. (“RCRA”); (d) the Toxic Substances Control Act, 15 U.S.C. §§2601 et seq.; (e) the Clean Water Act, 33 U.S.C. §§1251 et seq.; (f) the Clean Air Act, 42 U.S.C. §§7401 et seq.; or (g) any other federal, state, or local statute, law, rule, regulation, ordinance, resolution, code, order, or decree regulating, relating to, or imposing liability or standards of conduct concerning, any hazardous, toxic, or dangerous waste, substance, or material.
12. *Contract*—The entire and integrated written contract between the Owner and Contractor concerning the Work.
13. *Contract Documents*—Those items so designated in the Agreement, and which together comprise the Contract.
14. *Contract Price*—The money that Owner has agreed to pay Contractor for completion of the Work in accordance with the Contract Documents. .
15. *Contract Times*—The number of days or the dates by which Contractor shall: (a) achieve Milestones, if any; (b) achieve Substantial Completion; and (c) complete the Work.
16. *Contractor*—The individual or entity with which Owner has contracted for performance of the Work.
17. *Cost of the Work*—See Paragraph 13.01 for definition.
18. *Drawings*—The part of the Contract that graphically shows the scope, extent, and character of the Work to be performed by Contractor.
19. *Effective Date of the Contract*—The date, indicated in the Agreement, on which the Contract becomes effective.
20. *Engineer*—The individual or entity named as such in the Agreement.
21. *Field Order*—A written order issued by Engineer which requires minor changes in the Work but does not change the Contract Price or the Contract Times.
22. *Hazardous Environmental Condition*—The presence at the Site of Constituents of Concern in such quantities or circumstances that may present a danger to persons or property exposed thereto. The presence at the Site of materials that are necessary for the execution of the Work, or that are to be incorporated in the Work, and that are controlled and contained pursuant to industry practices, Laws and Regulations, and the requirements of the Contract, does not establish a Hazardous Environmental Condition.
23. *Laws and Regulations; Laws or Regulations*—Any and all applicable laws, statutes, rules, regulations, ordinances, codes, and orders of any and all governmental bodies, agencies, authorities, and courts having jurisdiction.

24. *Liens*—Charges, security interests, or encumbrances upon Contract-related funds, real property, or personal property.
25. *Milestone*—A principal event in the performance of the Work that the Contract requires Contractor to achieve by an intermediate completion date or by a time prior to Substantial Completion of all the Work.
26. *Notice of Award*—The written notice by Owner to a Bidder of Owner’s acceptance of the Bid.
27. *Notice to Proceed*—A written notice by Owner to Contractor fixing the date on which the Contract Times will commence to run and on which Contractor shall start to perform the Work.
28. *Owner*—The individual or entity with which Contractor has contracted regarding the Work, and which has agreed to pay Contractor for the performance of the Work, pursuant to the terms of the Contract.
29. *Progress Schedule*—A schedule, prepared and maintained by Contractor, describing the sequence and duration of the activities comprising the Contractor’s plan to accomplish the Work within the Contract Times.
30. *Project*—The total undertaking to be accomplished for Owner by engineers, contractors, and others, including planning, study, design, construction, testing, commissioning, and start-up, and of which the Work to be performed under the Contract Documents is a part.
31. *Project Manual*—The written documents prepared for, or made available for, procuring and constructing the Work, including but not limited to the Bidding Documents or other construction procurement documents, geotechnical and existing conditions information, the Agreement, bond forms, General Conditions, Supplementary Conditions, and Specifications. The contents of the Project Manual may be bound in one or more volumes.
32. *Resident Project Representative*—The authorized representative of Engineer assigned to assist Engineer at the Site. As used herein, the term Resident Project Representative or “RPR” includes any assistants or field staff of Resident Project Representative.
33. *Samples*—Physical examples of materials, equipment, or workmanship that are representative of some portion of the Work and that establish the standards by which such portion of the Work will be judged.
34. *Schedule of Submittals*—A schedule, prepared and maintained by Contractor, of required submittals and the time requirements for Engineer’s review of the submittals and the performance of related construction activities.
35. *Schedule of Values*—A schedule, prepared and maintained by Contractor, allocating portions of the Contract Price to various portions of the Work and used as the basis for reviewing Contractor’s Applications for Payment.
36. *Shop Drawings*—All drawings, diagrams, illustrations, schedules, and other data or information that are specifically prepared or assembled by or for Contractor and submitted by Contractor to illustrate some portion of the Work. Shop Drawings, whether approved or not, are not Drawings and are not Contract Documents.

37. *Site*—Lands or areas indicated in the Contract Documents as being furnished by Owner upon which the Work is to be performed, including rights-of-way and easements, and such other lands furnished by Owner which are designated for the use of Contractor.
38. *Specifications*—The part of the Contract that consists of written requirements for materials, equipment, systems, standards, and workmanship as applied to the Work, and certain administrative requirements and procedural matters applicable to the Work.
39. *Subcontractor*—An individual or entity having a direct contract with Contractor or with any other Subcontractor for the performance of a part of the Work.
40. *Substantial Completion*—The time at which the Work (or a specified part thereof) has progressed to the point where, in the opinion of Engineer, the Work (or a specified part thereof) is sufficiently complete, in accordance with the Contract Documents, so that the Work (or a specified part thereof) can be utilized for the purposes for which it is intended. The terms “substantially complete” and “substantially completed” as applied to all or part of the Work refer to Substantial Completion thereof.
41. *Successful Bidder*—The Bidder whose Bid the Owner accepts, and to which the Owner makes an award of contract, subject to stated conditions.
42. *Supplementary Conditions*—The part of the Contract that amends or supplements these General Conditions.
43. *Supplier*—A manufacturer, fabricator, supplier, distributor, materialman, or vendor having a direct contract with Contractor or with any Subcontractor to furnish materials or equipment to be incorporated in the Work by Contractor or a Subcontractor.
44. *Technical Data*—Those items expressly identified as Technical Data in the Supplementary Conditions, with respect to either (a) subsurface conditions at the Site, or physical conditions relating to existing surface or subsurface structures at the Site (except Underground Facilities) or (b) Hazardous Environmental Conditions at the Site. If no such express identifications of Technical Data have been made with respect to conditions at the Site, then the data contained in boring logs, recorded measurements of subsurface water levels, laboratory test results, and other factual, objective information regarding conditions at the Site that are set forth in any geotechnical or environmental report prepared for the Project and made available to Contractor are hereby defined as Technical Data with respect to conditions at the Site under Paragraphs 5.03, 5.04, and 5.06.
45. *Underground Facilities*—All underground pipelines, conduits, ducts, cables, wires, manholes, vaults, tanks, tunnels, or other such facilities or attachments, and any encasements containing such facilities, including but not limited to those that convey electricity, gases, steam, liquid petroleum products, telephone or other communications, fiber optic transmissions, cable television, water, wastewater, storm water, other liquids or chemicals, or traffic or other control systems.
46. *Unit Price Work*—Work to be paid for on the basis of unit prices.
47. *Work*—The entire construction or the various separately identifiable parts thereof required to be provided under the Contract Documents. Work includes and is the result of performing or providing all labor, services, and documentation necessary to produce such construction; furnishing, installing, and incorporating all materials and equipment into such construction; and may include related services such as testing, start-up, and commissioning, all as required by the Contract Documents.

48. *Work Change Directive*—A written directive to Contractor issued on or after the Effective Date of the Contract, signed by Owner and recommended by Engineer, ordering an addition, deletion, or revision in the Work.

1.02 Terminology

- A. The words and terms discussed in the following paragraphs are not defined but, when used in the Bidding Requirements or Contract Documents, have the indicated meaning.
- B. *Intent of Certain Terms or Adjectives:*
1. The Contract Documents include the terms “as allowed,” “as approved,” “as ordered,” “as directed” or terms of like effect or import to authorize an exercise of professional judgment by Engineer. In addition, the adjectives “reasonable,” “suitable,” “acceptable,” “proper,” “satisfactory,” or adjectives of like effect or import are used to describe an action or determination of Engineer as to the Work. It is intended that such exercise of professional judgment, action, or determination will be solely to evaluate, in general, the Work for compliance with the information in the Contract Documents and with the design concept of the Project as a functioning whole as shown or indicated in the Contract Documents (unless there is a specific statement indicating otherwise). The use of any such term or adjective is not intended to and shall not be effective to assign to Engineer any duty or authority to supervise or direct the performance of the Work, or any duty or authority to undertake responsibility contrary to the provisions of Article 10 or any other provision of the Contract Documents.
- C. *Day:*
1. The word “day” means a calendar day of 24 hours measured from midnight to the next midnight.
- D. *Defective:*
1. The word “defective,” when modifying the word “Work,” refers to Work that is unsatisfactory, faulty, or deficient in that it:
 - a. does not conform to the Contract Documents; or
 - b. does not meet the requirements of any applicable inspection, reference standard, test, or approval referred to in the Contract Documents; or
 - c. has been damaged prior to Engineer’s recommendation of final payment (unless responsibility for the protection thereof has been assumed by Owner at Substantial Completion in accordance with Paragraph 15.03 or 15.04).
- E. *Furnish, Install, Perform, Provide:*
1. The word “furnish,” when used in connection with services, materials, or equipment, shall mean to supply and deliver said services, materials, or equipment to the Site (or some other specified location) ready for use or installation and in usable or operable condition.
 2. The word “install,” when used in connection with services, materials, or equipment, shall mean to put into use or place in final position said services, materials, or equipment complete and ready for intended use.

3. The words “perform” or “provide,” when used in connection with services, materials, or equipment, shall mean to furnish and install said services, materials, or equipment complete and ready for intended use.
 4. If the Contract Documents establish an obligation of Contractor with respect to specific services, materials, or equipment, but do not expressly use any of the four words “furnish,” “install,” “perform,” or “provide,” then Contractor shall furnish and install said services, materials, or equipment complete and ready for intended use.
- F. Unless stated otherwise in the Contract Documents, words or phrases that have a well-known technical or construction industry or trade meaning are used in the Contract Documents in accordance with such recognized meaning.

ARTICLE 2 – PRELIMINARY MATTERS

2.01 *Delivery of Bonds and Evidence of Insurance*

- A. *Bonds*: When Contractor delivers the executed counterparts of the Agreement to Owner, Contractor shall also deliver to Owner such bonds as Contractor may be required to furnish.
- B. *Evidence of Contractor’s Insurance*: When Contractor delivers the executed counterparts of the Agreement to Owner, Contractor shall also deliver to Owner, with copies to each named insured and additional insured (as identified in the Supplementary Conditions or elsewhere in the Contract), the certificates and other evidence of insurance required to be provided by Contractor in accordance with Article 6.
- C. *Evidence of Owner’s Insurance*: After receipt of the executed counterparts of the Agreement and all required bonds and insurance documentation, Owner shall promptly deliver to Contractor, with copies to each named insured and additional insured (as identified in the Supplementary Conditions or otherwise), the certificates and other evidence of insurance required to be provided by Owner under Article 6.

2.02 *Copies of Documents*

- A. Owner shall furnish to Contractor four printed copies of the Contract (including one fully executed counterpart of the Agreement), and one copy in electronic portable document format (PDF). Additional printed copies will be furnished upon request at the cost of reproduction.
- B. Owner shall maintain and safeguard at least one original printed record version of the Contract, including Drawings and Specifications signed and sealed by Engineer and other design professionals. Owner shall make such original printed record version of the Contract available to Contractor for review. Owner may delegate the responsibilities under this provision to Engineer.

2.03 *Before Starting Construction*

- A. *Preliminary Schedules*: Within 10 days after the Effective Date of the Contract (or as otherwise specifically required by the Contract Documents), Contractor shall submit to Engineer for timely review:
 1. a preliminary Progress Schedule indicating the times (numbers of days or dates) for starting and completing the various stages of the Work, including any Milestones specified in the Contract;
 2. a preliminary Schedule of Submittals; and

3. a preliminary Schedule of Values for all of the Work which includes quantities and prices of items which when added together equal the Contract Price and subdivides the Work into component parts in sufficient detail to serve as the basis for progress payments during performance of the Work. Such prices will include an appropriate amount of overhead and profit applicable to each item of Work.

2.04 *Preconstruction Conference; Designation of Authorized Representatives*

- A. Before any Work at the Site is started, a conference attended by Owner, Contractor, Engineer, and others as appropriate will be held to establish a working understanding among the parties as to the Work and to discuss the schedules referred to in Paragraph 2.03.A, procedures for handling Shop Drawings, Samples, and other submittals, processing Applications for Payment, electronic or digital transmittals, and maintaining required records.
- B. At this conference Owner and Contractor each shall designate, in writing, a specific individual to act as its authorized representative with respect to the services and responsibilities under the Contract. Such individuals shall have the authority to transmit and receive information, render decisions relative to the Contract, and otherwise act on behalf of each respective party.

2.05 *Initial Acceptance of Schedules*

- A. At least 10 days before submission of the first Application for Payment a conference, attended by Contractor, Engineer, and others as appropriate, will be held to review for acceptability to Engineer as provided below the schedules submitted in accordance with Paragraph 2.03.A. Contractor shall have an additional 10 days to make corrections and adjustments and to complete and resubmit the schedules. No progress payment shall be made to Contractor until acceptable schedules are submitted to Engineer.
 1. The Progress Schedule will be acceptable to Engineer if it provides an orderly progression of the Work to completion within the Contract Times. Such acceptance will not impose on Engineer responsibility for the Progress Schedule, for sequencing, scheduling, or progress of the Work, nor interfere with or relieve Contractor from Contractor's full responsibility therefor.
 2. Contractor's Schedule of Submittals will be acceptable to Engineer if it provides a workable arrangement for reviewing and processing the required submittals.
 3. Contractor's Schedule of Values will be acceptable to Engineer as to form and substance if it provides a reasonable allocation of the Contract Price to the component parts of the Work.

2.06 *Electronic Transmittals*

- A. Except as otherwise stated elsewhere in the Contract, the Owner, Engineer, and Contractor may transmit, and shall accept, Project-related correspondence, text, data, documents, drawings, information, and graphics, including but not limited to Shop Drawings and other submittals, in electronic media or digital format, either directly, or through access to a secure Project website.
- B. If the Contract does not establish protocols for electronic or digital transmittals, then Owner, Engineer, and Contractor shall jointly develop such protocols.
- C. When transmitting items in electronic media or digital format, the transmitting party makes no representations as to long term compatibility, usability, or readability of the items resulting from the recipient's use of software application packages, operating systems, or

computer hardware differing from those used in the drafting or transmittal of the items, or from those established in applicable transmittal protocols.

ARTICLE 3 – DOCUMENTS: INTENT, REQUIREMENTS, REUSE

3.01 *Intent*

- A. The Contract Documents are complementary; what is required by one is as binding as if required by all.
- B. It is the intent of the Contract Documents to describe a functionally complete project (or part thereof) to be constructed in accordance with the Contract Documents.
- C. Unless otherwise stated in the Contract Documents, if there is a discrepancy between the electronic or digital versions of the Contract Documents (including any printed copies derived from such electronic or digital versions) and the printed record version, the printed record version shall govern.
- D. The Contract supersedes prior negotiations, representations, and agreements, whether written or oral.
- E. Engineer will issue clarifications and interpretations of the Contract Documents as provided herein.

3.02 *Reference Standards*

- A. Standards Specifications, Codes, Laws and Regulations
 - 1. Reference in the Contract Documents to standard specifications, manuals, reference standards, or codes of any technical society, organization, or association, or to Laws or Regulations, whether such reference be specific or by implication, shall mean the standard specification, manual, reference standard, code, or Laws or Regulations in effect at the time of opening of Bids (or on the Effective Date of the Contract if there were no Bids), except as may be otherwise specifically stated in the Contract Documents.
 - 2. No provision of any such standard specification, manual, reference standard, or code, or any instruction of a Supplier, shall be effective to change the duties or responsibilities of Owner, Contractor, or Engineer, or any of their subcontractors, consultants, agents, or employees, from those set forth in the part of the Contract Documents prepared by or for Engineer. No such provision or instruction shall be effective to assign to Owner, Engineer, or any of their officers, directors, members, partners, employees, agents, consultants, or subcontractors, any duty or authority to supervise or direct the performance of the Work or any duty or authority to undertake responsibility inconsistent with the provisions of the part of the Contract Documents prepared by or for Engineer.

3.03 *Reporting and Resolving Discrepancies*

- A. *Reporting Discrepancies:*
 - 1. *Contractor's Verification of Figures and Field Measurements:* Before undertaking each part of the Work, Contractor shall carefully study the Contract Documents, and check and verify pertinent figures and dimensions therein, particularly with respect to applicable field measurements. Contractor shall promptly report in writing to Engineer any conflict, error, ambiguity, or discrepancy that Contractor discovers, or has actual knowledge of, and shall not proceed with any Work affected thereby until the conflict,

error, ambiguity, or discrepancy is resolved, by a clarification or interpretation by Engineer, or by an amendment or supplement to the Contract Documents issued pursuant to Paragraph 11.01.

2. *Contractor's Review of Contract Documents:* If, before or during the performance of the Work, Contractor discovers any conflict, error, ambiguity, or discrepancy within the Contract Documents, or between the Contract Documents and (a) any applicable Law or Regulation, (b) actual field conditions, (c) any standard specification, manual, reference standard, or code, or (d) any instruction of any Supplier, then Contractor shall promptly report it to Engineer in writing. Contractor shall not proceed with the Work affected thereby (except in an emergency as required by Paragraph 7.15) until the conflict, error, ambiguity, or discrepancy is resolved, by a clarification or interpretation by Engineer, or by an amendment or supplement to the Contract Documents issued pursuant to Paragraph 11.01.
3. Contractor shall not be liable to Owner or Engineer for failure to report any conflict, error, ambiguity, or discrepancy in the Contract Documents unless Contractor had actual knowledge thereof.

B. *Resolving Discrepancies:*

1. Except as may be otherwise specifically stated in the Contract Documents, the provisions of the part of the Contract Documents prepared by or for Engineer shall take precedence in resolving any conflict, error, ambiguity, or discrepancy between such provisions of the Contract Documents and:
 - a. the provisions of any standard specification, manual, reference standard, or code, or the instruction of any Supplier (whether or not specifically incorporated by reference as a Contract Document); or
 - b. the provisions of any Laws or Regulations applicable to the performance of the Work (unless such an interpretation of the provisions of the Contract Documents would result in violation of such Law or Regulation).

3.04 *Requirements of the Contract Documents*

- A. During the performance of the Work and until final payment, Contractor and Owner shall submit to the Engineer all matters in question concerning the requirements of the Contract Documents (sometimes referred to as requests for information or interpretation—RFIs), or relating to the acceptability of the Work under the Contract Documents, as soon as possible after such matters arise. Engineer will be the initial interpreter of the requirements of the Contract Documents, and judge of the acceptability of the Work thereunder.
- B. Engineer will, with reasonable promptness, render a written clarification, interpretation, or decision on the issue submitted, or initiate an amendment or supplement to the Contract Documents. Engineer's written clarification, interpretation, or decision will be final and binding on Contractor, unless it appeals by submitting a Change Proposal, and on Owner, unless it appeals by filing a Claim.
- C. If a submitted matter in question concerns terms and conditions of the Contract Documents that do not involve (1) the performance or acceptability of the Work under the Contract Documents, (2) the design (as set forth in the Drawings, Specifications, or otherwise), or (3) other engineering or technical matters, then Engineer will promptly give written notice to Owner and Contractor that Engineer is unable to provide a decision or interpretation. If Owner and Contractor are unable to agree on resolution of such a matter in question, either party may pursue resolution as provided in Article 12.

3.05 *Reuse of Documents*

- A. Contractor and its Subcontractors and Suppliers shall not:
 - 1. have or acquire any title to or ownership rights in any of the Drawings, Specifications, or other documents (or copies of any thereof) prepared by or bearing the seal of Engineer or its consultants, including electronic media editions, or reuse any such Drawings, Specifications, other documents, or copies thereof on extensions of the Project or any other project without written consent of Owner and Engineer and specific written verification or adaptation by Engineer; or
 - 2. have or acquire any title or ownership rights in any other Contract Documents, reuse any such Contract Documents for any purpose without Owner's express written consent, or violate any copyrights pertaining to such Contract Documents.
- B. The prohibitions of this Paragraph 3.05 will survive final payment, or termination of the Contract. Nothing herein shall preclude Contractor from retaining copies of the Contract Documents for record purposes.

ARTICLE 4 – COMMENCEMENT AND PROGRESS OF THE WORK

4.01 *Commencement of Contract Times; Notice to Proceed*

- A. The Contract Times will commence to run on the thirtieth day after the Effective Date of the Contract or, if a Notice to Proceed is given, on the day indicated in the Notice to Proceed. A Notice to Proceed may be given at any time within 30 days after the Effective Date of the Contract. In no event will the Contract Times commence to run later than the sixtieth day after the day of Bid opening or the thirtieth day after the Effective Date of the Contract, whichever date is earlier.

4.02 *Starting the Work*

- A. Contractor shall start to perform the Work on the date when the Contract Times commence to run. No Work shall be done at the Site prior to such date.

4.03 *Reference Points*

- A. Owner shall provide engineering surveys to establish reference points for construction which in Engineer's judgment are necessary to enable Contractor to proceed with the Work. Contractor shall be responsible for laying out the Work, shall protect and preserve the established reference points and property monuments, and shall make no changes or relocations without the prior written approval of Owner. Contractor shall report to Engineer whenever any reference point or property monument is lost or destroyed or requires relocation because of necessary changes in grades or locations, and shall be responsible for the accurate replacement or relocation of such reference points or property monuments by professionally qualified personnel.

4.04 *Progress Schedule*

- A. Contractor shall adhere to the Progress Schedule established in accordance with Paragraph 2.05 as it may be adjusted from time to time as provided below.
 - 1. Contractor shall submit to Engineer for acceptance (to the extent indicated in Paragraph 2.05) proposed adjustments in the Progress Schedule that will not result in changing the Contract Times.

2. Proposed adjustments in the Progress Schedule that will change the Contract Times shall be submitted in accordance with the requirements of Article 11.
- B. Contractor shall carry on the Work and adhere to the Progress Schedule during all disputes or disagreements with Owner. No Work shall be delayed or postponed pending resolution of any disputes or disagreements, or during any appeal process, except as permitted by Paragraph 16.04, or as Owner and Contractor may otherwise agree in writing.

4.05 *Delays in Contractor's Progress*

- A. If Owner, Engineer, or anyone for whom Owner is responsible, delays, disrupts, or interferes with the performance or progress of the Work, then Contractor shall be entitled to an equitable adjustment in the Contract Times and Contract Price. Contractor's entitlement to an adjustment of the Contract Times is conditioned on such adjustment being essential to Contractor's ability to complete the Work within the Contract Times.
- B. Contractor shall not be entitled to an adjustment in Contract Price or Contract Times for delay, disruption, or interference caused by or within the control of Contractor. Delay, disruption, and interference attributable to and within the control of a Subcontractor or Supplier shall be deemed to be within the control of Contractor.
- C. If Contractor's performance or progress is delayed, disrupted, or interfered with by unanticipated causes not the fault of and beyond the control of Owner, Contractor, and those for which they are responsible, then Contractor shall be entitled to an equitable adjustment in Contract Times. Contractor's entitlement to an adjustment of the Contract Times is conditioned on such adjustment being essential to Contractor's ability to complete the Work within the Contract Times. Such an adjustment shall be Contractor's sole and exclusive remedy for the delays, disruption, and interference described in this paragraph. Causes of delay, disruption, or interference that may give rise to an adjustment in Contract Times under this paragraph include but are not limited to the following:
1. severe and unavoidable natural catastrophes such as fires, floods, epidemics, and earthquakes;
 2. abnormal weather conditions;
 3. acts or failures to act of utility owners (other than those performing other work at or adjacent to the Site by arrangement with the Owner, as contemplated in Article 8); and
 4. acts of war or terrorism.
- D. Delays, disruption, and interference to the performance or progress of the Work resulting from the existence of a differing subsurface or physical condition, an Underground Facility that was not shown or indicated by the Contract Documents, or not shown or indicated with reasonable accuracy, and those resulting from Hazardous Environmental Conditions, are governed by Article 5.
- E. Paragraph 8.03 governs delays, disruption, and interference to the performance or progress of the Work resulting from the performance of certain other work at or adjacent to the Site.
- F. Contractor shall not be entitled to an adjustment in Contract Price or Contract Times for any delay, disruption, or interference if such delay is concurrent with a delay, disruption, or interference caused by or within the control of Contractor.

- G. Contractor must submit any Change Proposal seeking an adjustment in Contract Price or Contract Times under this paragraph within 30 days of the commencement of the delaying, disrupting, or interfering event.

ARTICLE 5 – AVAILABILITY OF LANDS; SUBSURFACE AND PHYSICAL CONDITIONS; HAZARDOUS ENVIRONMENTAL CONDITIONS

5.01 *Availability of Lands*

- A. Owner shall furnish the Site. Owner shall notify Contractor of any encumbrances or restrictions not of general application but specifically related to use of the Site with which Contractor must comply in performing the Work.
- B. Upon reasonable written request, Owner shall furnish Contractor with a current statement of record legal title and legal description of the lands upon which permanent improvements are to be made and Owner's interest therein as necessary for giving notice of or filing a mechanic's or construction lien against such lands in accordance with applicable Laws and Regulations.
- C. Contractor shall provide for all additional lands and access thereto that may be required for temporary construction facilities or storage of materials and equipment.

5.02 *Use of Site and Other Areas*

- A. *Limitation on Use of Site and Other Areas:*
 - 1. Contractor shall confine construction equipment, temporary construction facilities, the storage of materials and equipment, and the operations of workers to the Site, adjacent areas that Contractor has arranged to use through construction easements or otherwise, and other adjacent areas permitted by Laws and Regulations, and shall not unreasonably encumber the Site and such other adjacent areas with construction equipment or other materials or equipment. Contractor shall assume full responsibility for (a) damage to the Site; (b) damage to any such other adjacent areas used for Contractor's operations; (c) damage to any other adjacent land or areas; and (d) for injuries and losses sustained by the owners or occupants of any such land or areas; provided that such damage or injuries result from the performance of the Work or from other actions or conduct of the Contractor or those for which Contractor is responsible.
 - 2. If a damage or injury claim is made by the owner or occupant of any such land or area because of the performance of the Work, or because of other actions or conduct of the Contractor or those for which Contractor is responsible, Contractor shall (a) take immediate corrective or remedial action as required by Paragraph 7.12, or otherwise; (b) promptly attempt to settle the claim as to all parties through negotiations with such owner or occupant, or otherwise resolve the claim by arbitration or other dispute resolution proceeding, or at law; and (c) to the fullest extent permitted by Laws and Regulations, indemnify and hold harmless Owner and Engineer, and the officers, directors, members, partners, employees, agents, consultants and subcontractors of each and any of them from and against any such claim, and against all costs, losses, and damages (including but not limited to all fees and charges of engineers, architects, attorneys, and other professionals and all court or arbitration or other dispute resolution costs) arising out of or relating to any claim or action, legal or equitable, brought by any such owner or occupant against Owner, Engineer, or any other party indemnified hereunder to the extent caused directly or indirectly, in whole or in part

by, or based upon, Contractor's performance of the Work, or because of other actions or conduct of the Contractor or those for which Contractor is responsible.

- B. *Removal of Debris During Performance of the Work:* During the progress of the Work the Contractor shall keep the Site and other adjacent areas free from accumulations of waste materials, rubbish, and other debris. Removal and disposal of such waste materials, rubbish, and other debris shall conform to applicable Laws and Regulations.
- C. *Cleaning:* Prior to Substantial Completion of the Work Contractor shall clean the Site and the Work and make it ready for utilization by Owner. At the completion of the Work Contractor shall remove from the Site and adjacent areas all tools, appliances, construction equipment and machinery, and surplus materials and shall restore to original condition all property not designated for alteration by the Contract Documents.
- D. *Loading of Structures:* Contractor shall not load nor permit any part of any structure to be loaded in any manner that will endanger the structure, nor shall Contractor subject any part of the Work or adjacent structures or land to stresses or pressures that will endanger them.

5.03 *Subsurface and Physical Conditions*

- A. *Reports and Drawings:* The Supplementary Conditions identify:
 - 1. those reports known to Owner of explorations and tests of subsurface conditions at or adjacent to the Site;
 - 2. those drawings known to Owner of physical conditions relating to existing surface or subsurface structures at the Site (except Underground Facilities); and
 - 3. Technical Data contained in such reports and drawings.
- B. *Reliance by Contractor on Technical Data Authorized:* Contractor may rely upon the accuracy of the Technical Data expressly identified in the Supplementary Conditions with respect to such reports and drawings, but such reports and drawings are not Contract Documents. If no such express identification has been made, then Contractor may rely upon the accuracy of the Technical Data (as defined in Article 1) contained in any geotechnical or environmental report prepared for the Project and made available to Contractor. Except for such reliance on Technical Data, Contractor may not rely upon or make any claim against Owner or Engineer, or any of their officers, directors, members, partners, employees, agents, consultants, or subcontractors, with respect to:
 - 1. the completeness of such reports and drawings for Contractor's purposes, including, but not limited to, any aspects of the means, methods, techniques, sequences, and procedures of construction to be employed by Contractor, and safety precautions and programs incident thereto; or
 - 2. other data, interpretations, opinions, and information contained in such reports or shown or indicated in such drawings; or
 - 3. any Contractor interpretation of or conclusion drawn from any Technical Data or any such other data, interpretations, opinions, or information.

5.04 *Differing Subsurface or Physical Conditions*

- A. *Notice by Contractor:* If Contractor believes that any subsurface or physical condition that is uncovered or revealed at the Site either:
1. is of such a nature as to establish that any Technical Data on which Contractor is entitled to rely as provided in Paragraph 5.03 is materially inaccurate; or
 2. is of such a nature as to require a change in the Drawings or Specifications; or
 3. differs materially from that shown or indicated in the Contract Documents; or
 4. is of an unusual nature, and differs materially from conditions ordinarily encountered and generally recognized as inherent in work of the character provided for in the Contract Documents;

then Contractor shall, promptly after becoming aware thereof and before further disturbing the subsurface or physical conditions or performing any Work in connection therewith (except in an emergency as required by Paragraph 7.15), notify Owner and Engineer in writing about such condition. Contractor shall not further disturb such condition or perform any Work in connection therewith (except with respect to an emergency) until receipt of a written statement permitting Contractor to do so.

- B. *Engineer's Review:* After receipt of written notice as required by the preceding paragraph, Engineer will promptly review the subsurface or physical condition in question; determine the necessity of Owner's obtaining additional exploration or tests with respect to the condition; conclude whether the condition falls within any one or more of the differing site condition categories in Paragraph 5.04.A above; obtain any pertinent cost or schedule information from Contractor; prepare recommendations to Owner regarding the Contractor's resumption of Work in connection with the subsurface or physical condition in question and the need for any change in the Drawings or Specifications; and advise Owner in writing of Engineer's findings, conclusions, and recommendations.
- C. *Owner's Statement to Contractor Regarding Site Condition:* After receipt of Engineer's written findings, conclusions, and recommendations, Owner shall issue a written statement to Contractor (with a copy to Engineer) regarding the subsurface or physical condition in question, addressing the resumption of Work in connection with such condition, indicating whether any change in the Drawings or Specifications will be made, and adopting or rejecting Engineer's written findings, conclusions, and recommendations, in whole or in part.
- D. *Possible Price and Times Adjustments:*
1. Contractor shall be entitled to an equitable adjustment in Contract Price or Contract Times, or both, to the extent that the existence of a differing subsurface or physical condition, or any related delay, disruption, or interference, causes an increase or decrease in Contractor's cost of, or time required for, performance of the Work; subject, however, to the following:
 - a. such condition must fall within any one or more of the categories described in Paragraph 5.04.A;
 - b. with respect to Work that is paid for on a unit price basis, any adjustment in Contract Price will be subject to the provisions of Paragraph 13.03; and,

- c. Contractor's entitlement to an adjustment of the Contract Times is conditioned on such adjustment being essential to Contractor's ability to complete the Work within the Contract Times.
2. Contractor shall not be entitled to any adjustment in the Contract Price or Contract Times with respect to a subsurface or physical condition if:
 - a. Contractor knew of the existence of such condition at the time Contractor made a commitment to Owner with respect to Contract Price and Contract Times by the submission of a Bid or becoming bound under a negotiated contract, or otherwise; or
 - b. the existence of such condition reasonably could have been discovered or revealed as a result of any examination, investigation, exploration, test, or study of the Site and contiguous areas expressly required by the Bidding Requirements or Contract Documents to be conducted by or for Contractor prior to Contractor's making such commitment; or
 - c. Contractor failed to give the written notice as required by Paragraph 5.04.A.
3. If Owner and Contractor agree regarding Contractor's entitlement to and the amount or extent of any adjustment in the Contract Price or Contract Times, or both, then any such adjustment shall be set forth in a Change Order.
4. Contractor may submit a Change Proposal regarding its entitlement to or the amount or extent of any adjustment in the Contract Price or Contract Times, or both, no later than 30 days after Owner's issuance of the Owner's written statement to Contractor regarding the subsurface or physical condition in question.

5.05 *Underground Facilities*

- A. *Contractor's Responsibilities:* The information and data shown or indicated in the Contract Documents with respect to existing Underground Facilities at or adjacent to the Site is based on information and data furnished to Owner or Engineer by the owners of such Underground Facilities, including Owner, or by others. Unless it is otherwise expressly provided in the Supplementary Conditions:
 1. Owner and Engineer do not warrant or guarantee the accuracy or completeness of any such information or data provided by others; and
 2. the cost of all of the following will be included in the Contract Price, and Contractor shall have full responsibility for:
 - a. reviewing and checking all information and data regarding existing Underground Facilities at the Site;
 - b. locating all Underground Facilities shown or indicated in the Contract Documents as being at the Site;
 - c. coordination of the Work with the owners (including Owner) of such Underground Facilities, during construction; and
 - d. the safety and protection of all existing Underground Facilities at the Site, and repairing any damage thereto resulting from the Work.
- B. *Notice by Contractor:* If Contractor believes that an Underground Facility that is uncovered or revealed at the Site was not shown or indicated in the Contract Documents, or was not shown or indicated with reasonable accuracy, then Contractor shall, promptly after

becoming aware thereof and before further disturbing conditions affected thereby or performing any Work in connection therewith (except in an emergency as required by Paragraph 7.15), identify the owner of such Underground Facility and give written notice to that owner and to Owner and Engineer.

- C. *Engineer's Review:* Engineer will promptly review the Underground Facility and conclude whether such Underground Facility was not shown or indicated in the Contract Documents, or was not shown or indicated with reasonable accuracy; obtain any pertinent cost or schedule information from Contractor; prepare recommendations to Owner regarding the Contractor's resumption of Work in connection with the Underground Facility in question; determine the extent, if any, to which a change is required in the Drawings or Specifications to reflect and document the consequences of the existence or location of the Underground Facility; and advise Owner in writing of Engineer's findings, conclusions, and recommendations. During such time, Contractor shall be responsible for the safety and protection of such Underground Facility.
- D. *Owner's Statement to Contractor Regarding Underground Facility:* After receipt of Engineer's written findings, conclusions, and recommendations, Owner shall issue a written statement to Contractor (with a copy to Engineer) regarding the Underground Facility in question, addressing the resumption of Work in connection with such Underground Facility, indicating whether any change in the Drawings or Specifications will be made, and adopting or rejecting Engineer's written findings, conclusions, and recommendations in whole or in part.
- E. *Possible Price and Times Adjustments:*
 - 1. Contractor shall be entitled to an equitable adjustment in the Contract Price or Contract Times, or both, to the extent that any existing Underground Facility at the Site that was not shown or indicated in the Contract Documents, or was not shown or indicated with reasonable accuracy, or any related delay, disruption, or interference, causes an increase or decrease in Contractor's cost of, or time required for, performance of the Work; subject, however, to the following:
 - a. Contractor did not know of and could not reasonably have been expected to be aware of or to have anticipated the existence or actual location of the Underground Facility in question;
 - b. With respect to Work that is paid for on a unit price basis, any adjustment in Contract Price will be subject to the provisions of Paragraph 13.03;
 - c. Contractor's entitlement to an adjustment of the Contract Times is conditioned on such adjustment being essential to Contractor's ability to complete the Work within the Contract Times; and
 - d. Contractor gave the notice required in Paragraph 5.05.B.
 - 2. If Owner and Contractor agree regarding Contractor's entitlement to and the amount or extent of any adjustment in the Contract Price or Contract Times, or both, then any such adjustment shall be set forth in a Change Order.
 - 3. Contractor may submit a Change Proposal regarding its entitlement to or the amount or extent of any adjustment in the Contract Price or Contract Times, or both, no later than 30 days after Owner's issuance of the Owner's written statement to Contractor regarding the Underground Facility in question.

5.06 *Hazardous Environmental Conditions at Site*

- A. *Reports and Drawings*: The Supplementary Conditions identify:
1. those reports and drawings known to Owner relating to Hazardous Environmental Conditions that have been identified at or adjacent to the Site; and
 2. Technical Data contained in such reports and drawings.
- B. *Reliance by Contractor on Technical Data Authorized*: Contractor may rely upon the accuracy of the Technical Data expressly identified in the Supplementary Conditions with respect to such reports and drawings, but such reports and drawings are not Contract Documents. If no such express identification has been made, then Contractor may rely on the accuracy of the Technical Data (as defined in Article 1) contained in any geotechnical or environmental report prepared for the Project and made available to Contractor. Except for such reliance on Technical Data, Contractor may not rely upon or make any claim against Owner or Engineer, or any of their officers, directors, members, partners, employees, agents, consultants, or subcontractors with respect to:
1. the completeness of such reports and drawings for Contractor's purposes, including, but not limited to, any aspects of the means, methods, techniques, sequences and procedures of construction to be employed by Contractor and safety precautions and programs incident thereto; or
 2. other data, interpretations, opinions and information contained in such reports or shown or indicated in such drawings; or
 3. any Contractor interpretation of or conclusion drawn from any Technical Data or any such other data, interpretations, opinions or information.
- C. Contractor shall not be responsible for removing or remediating any Hazardous Environmental Condition encountered, uncovered, or revealed at the Site unless such removal or remediation is expressly identified in the Contract Documents to be within the scope of the Work.
- D. Contractor shall be responsible for controlling, containing, and duly removing all Constituents of Concern brought to the Site by Contractor, Subcontractors, Suppliers, or anyone else for whom Contractor is responsible, and for any associated costs; and for the costs of removing and remediating any Hazardous Environmental Condition created by the presence of any such Constituents of Concern.
- E. If Contractor encounters, uncovers, or reveals a Hazardous Environmental Condition whose removal or remediation is not expressly identified in the Contract Documents as being within the scope of the Work, or if Contractor or anyone for whom Contractor is responsible creates a Hazardous Environmental Condition, then Contractor shall immediately: (1) secure or otherwise isolate such condition; (2) stop all Work in connection with such condition and in any area affected thereby (except in an emergency as required by Paragraph 7.15); and (3) notify Owner and Engineer (and promptly thereafter confirm such notice in writing). Owner shall promptly consult with Engineer concerning the necessity for Owner to retain a qualified expert to evaluate such condition or take corrective action, if any. Promptly after consulting with Engineer, Owner shall take such actions as are necessary to permit Owner to timely obtain required permits and provide Contractor the written notice required by Paragraph 5.06.F. If Contractor or anyone for whom Contractor is responsible created the Hazardous Environmental Condition in question, then Owner may remove and remediate the Hazardous Environmental Condition, and impose a set-off against payments to account for the associated costs.

- F. Contractor shall not resume Work in connection with such Hazardous Environmental Condition or in any affected area until after Owner has obtained any required permits related thereto, and delivered written notice to Contractor either (1) specifying that such condition and any affected area is or has been rendered safe for the resumption of Work, or (2) specifying any special conditions under which such Work may be resumed safely.
- G. If Owner and Contractor cannot agree as to entitlement to or on the amount or extent, if any, of any adjustment in Contract Price or Contract Times, or both, as a result of such Work stoppage or such special conditions under which Work is agreed to be resumed by Contractor, then within 30 days of Owner's written notice regarding the resumption of Work, Contractor may submit a Change Proposal, or Owner may impose a set-off.
- H. If after receipt of such written notice Contractor does not agree to resume such Work based on a reasonable belief it is unsafe, or does not agree to resume such Work under such special conditions, then Owner may order the portion of the Work that is in the area affected by such condition to be deleted from the Work, following the contractual change procedures in Article 11. Owner may have such deleted portion of the Work performed by Owner's own forces or others in accordance with Article 8.
- I. To the fullest extent permitted by Laws and Regulations, Owner shall indemnify and hold harmless Contractor, Subcontractors, and Engineer, and the officers, directors, members, partners, employees, agents, consultants, and subcontractors of each and any of them from and against all claims, costs, losses, and damages (including but not limited to all fees and charges of engineers, architects, attorneys, and other professionals and all court or arbitration or other dispute resolution costs) arising out of or relating to a Hazardous Environmental Condition, provided that such Hazardous Environmental Condition (1) was not shown or indicated in the Drawings, Specifications, or other Contract Documents, identified as Technical Data entitled to limited reliance pursuant to Paragraph 5.06.B, or identified in the Contract Documents to be included within the scope of the Work, and (2) was not created by Contractor or by anyone for whom Contractor is responsible. Nothing in this Paragraph 5.06.I shall obligate Owner to indemnify any individual or entity from and against the consequences of that individual's or entity's own negligence.
- J. To the fullest extent permitted by Laws and Regulations, Contractor shall indemnify and hold harmless Owner and Engineer, and the officers, directors, members, partners, employees, agents, consultants, and subcontractors of each and any of them from and against all claims, costs, losses, and damages (including but not limited to all fees and charges of engineers, architects, attorneys, and other professionals and all court or arbitration or other dispute resolution costs) arising out of or relating to the failure to control, contain, or remove a Constituent of Concern brought to the Site by Contractor or by anyone for whom Contractor is responsible, or to a Hazardous Environmental Condition created by Contractor or by anyone for whom Contractor is responsible. Nothing in this Paragraph 5.06.J shall obligate Contractor to indemnify any individual or entity from and against the consequences of that individual's or entity's own negligence.
- K. The provisions of Paragraphs 5.03, 5.04, and 5.05 do not apply to the presence of Constituents of Concern or to a Hazardous Environmental Condition uncovered or revealed at the Site.

ARTICLE 6 – BONDS AND INSURANCE

6.01 *Performance, Payment, and Other Bonds*

- A. Contractor shall furnish a performance bond and a payment bond, each in an amount at least equal to the Contract Price, as security for the faithful performance and payment of all of Contractor's obligations under the Contract. These bonds shall remain in effect until one year after the date when final payment becomes due or until completion of the correction period specified in Paragraph 15.08, whichever is later, except as provided otherwise by Laws or Regulations, the Supplementary Conditions, or other specific provisions of the Contract. Contractor shall also furnish such other bonds as are required by the Supplementary Conditions or other specific provisions of the Contract.
- B. All bonds shall be in the form prescribed by the Contract except as provided otherwise by Laws or Regulations, and shall be executed by such sureties as are named in "Companies Holding Certificates of Authority as Acceptable Sureties on Federal Bonds and as Acceptable Reinsuring Companies" as published in Circular 570 (as amended and supplemented) by the Financial Management Service, Surety Bond Branch, U.S. Department of the Treasury. A bond signed by an agent or attorney-in-fact must be accompanied by a certified copy of that individual's authority to bind the surety. The evidence of authority shall show that it is effective on the date the agent or attorney-in-fact signed the accompanying bond.
- C. Contractor shall obtain the required bonds from surety companies that are duly licensed or authorized in the jurisdiction in which the Project is located to issue bonds in the required amounts.
- D. If the surety on a bond furnished by Contractor is declared bankrupt or becomes insolvent, or its right to do business is terminated in any state or jurisdiction where any part of the Project is located, or the surety ceases to meet the requirements above, then Contractor shall promptly notify Owner and Engineer and shall, within 20 days after the event giving rise to such notification, provide another bond and surety, both of which shall comply with the bond and surety requirements above.
- E. If Contractor has failed to obtain a required bond, Owner may exclude the Contractor from the Site and exercise Owner's termination rights under Article 16.
- F. Upon request, Owner shall provide a copy of the payment bond to any Subcontractor, Supplier, or other person or entity claiming to have furnished labor or materials used in the performance of the Work.

6.02 *Insurance—General Provisions*

- A. Owner and Contractor shall obtain and maintain insurance as required in this Article and in the Supplementary Conditions.
- B. All insurance required by the Contract to be purchased and maintained by Owner or Contractor shall be obtained from insurance companies that are duly licensed or authorized, in the state or jurisdiction in which the Project is located, to issue insurance policies for the required limits and coverages. Unless a different standard is indicated in the Supplementary Conditions, all companies that provide insurance policies required under this Contract shall have an A.M. Best rating of A-VII or better.
- C. Contractor shall deliver to Owner, with copies to each named insured and additional insured (as identified in this Article, in the Supplementary Conditions, or elsewhere in the Contract), certificates of insurance establishing that Contractor has obtained and is

maintaining the policies, coverages, and endorsements required by the Contract. Upon request by Owner or any other insured, Contractor shall also furnish other evidence of such required insurance, including but not limited to copies of policies and endorsements, and documentation of applicable self-insured retentions and deductibles. Contractor may block out (redact) any confidential premium or pricing information contained in any policy or endorsement furnished under this provision.

- D. Owner shall deliver to Contractor, with copies to each named insured and additional insured (as identified in this Article, the Supplementary Conditions, or elsewhere in the Contract), certificates of insurance establishing that Owner has obtained and is maintaining the policies, coverages, and endorsements required of Owner by the Contract (if any). Upon request by Contractor or any other insured, Owner shall also provide other evidence of such required insurance (if any), including but not limited to copies of policies and endorsements, and documentation of applicable self-insured retentions and deductibles. Owner may block out (redact) any confidential premium or pricing information contained in any policy or endorsement furnished under this provision.
- E. Failure of Owner or Contractor to demand such certificates or other evidence of the other party's full compliance with these insurance requirements, or failure of Owner or Contractor to identify a deficiency in compliance from the evidence provided, shall not be construed as a waiver of the other party's obligation to obtain and maintain such insurance.
- F. If either party does not purchase or maintain all of the insurance required of such party by the Contract, such party shall notify the other party in writing of such failure to purchase prior to the start of the Work, or of such failure to maintain prior to any change in the required coverage.
- G. If Contractor has failed to obtain and maintain required insurance, Owner may exclude the Contractor from the Site, impose an appropriate set-off against payment, and exercise Owner's termination rights under Article 16.
- H. Without prejudice to any other right or remedy, if a party has failed to obtain required insurance, the other party may elect to obtain equivalent insurance to protect such other party's interests at the expense of the party who was required to provide such coverage, and the Contract Price shall be adjusted accordingly.
- I. Owner does not represent that insurance coverage and limits established in this Contract necessarily will be adequate to protect Contractor or Contractor's interests.
- J. The insurance and insurance limits required herein shall not be deemed as a limitation on Contractor's liability under the indemnities granted to Owner and other individuals and entities in the Contract.

6.03 *Contractor's Insurance*

- A. *Workers' Compensation:* Contractor shall purchase and maintain workers' compensation and employer's liability insurance for:
 - 1. claims under workers' compensation, disability benefits, and other similar employee benefit acts.
 - 2. United States Longshoreman and Harbor Workers' Compensation Act and Jones Act coverage (if applicable).
 - 3. claims for damages because of bodily injury, occupational sickness or disease, or death of Contractor's employees (by stop-gap endorsement in monopolist worker's compensation states).

4. Foreign voluntary worker compensation (if applicable).
- B. *Commercial General Liability—Claims Covered:* Contractor shall purchase and maintain commercial general liability insurance, covering all operations by or on behalf of Contractor, on an occurrence basis, against:
1. claims for damages because of bodily injury, sickness or disease, or death of any person other than Contractor's employees.
 2. claims for damages insured by reasonably available personal injury liability coverage.
 3. claims for damages, other than to the Work itself, because of injury to or destruction of tangible property wherever located, including loss of use resulting therefrom.
- C. *Commercial General Liability—Form and Content:* Contractor's commercial liability policy shall be written on a 1996 (or later) ISO commercial general liability form (occurrence form) and include the following coverages and endorsements:
1. Products and completed operations coverage:
 - a. Such insurance shall be maintained for three years after final payment.
 - b. Contractor shall furnish Owner and each other additional insured (as identified in the Supplementary Conditions or elsewhere in the Contract) evidence of continuation of such insurance at final payment and three years thereafter.
 2. Blanket contractual liability coverage, to the extent permitted by law, including but not limited to coverage of Contractor's contractual indemnity obligations in Paragraph 7.18.
 3. Broad form property damage coverage.
 4. Severability of interest.
 5. Underground, explosion, and collapse coverage.
 6. Personal injury coverage.
 7. Additional insured endorsements that include both ongoing operations and products and completed operations coverage through ISO Endorsements CG 20 10 10 01 and CG 20 37 10 01 (together); or CG 20 10 07 04 and CG 20 37 07 04 (together); or their equivalent.
 8. For design professional additional insureds, ISO Endorsement CG 20 32 07 04, "Additional Insured—Engineers, Architects or Surveyors Not Engaged by the Named Insured" or its equivalent.
- D. *Automobile liability:* Contractor shall purchase and maintain automobile liability insurance against claims for damages because of bodily injury or death of any person or property damage arising out of the ownership, maintenance, or use of any motor vehicle. The automobile liability policy shall be written on an occurrence basis.
- E. *Umbrella or excess liability:* Contractor shall purchase and maintain umbrella or excess liability insurance written over the underlying employer's liability, commercial general liability, and automobile liability insurance described in the paragraphs above. Subject to industry-standard exclusions, the coverage afforded shall follow form as to each and every one of the underlying policies.
- F. *Contractor's pollution liability insurance:* Contractor shall purchase and maintain a policy covering third-party injury and property damage claims, including clean-up costs, as a result

of pollution conditions arising from Contractor's operations and completed operations. This insurance shall be maintained for no less than three years after final completion.

- G. *Additional insureds*: The Contractor's commercial general liability, automobile liability, umbrella or excess, and pollution liability policies shall include and list as additional insureds Owner and Engineer, and any individuals or entities identified in the Supplementary Conditions; include coverage for the respective officers, directors, members, partners, employees, agents, consultants, and subcontractors of each and any of all such additional insureds; and the insurance afforded to these additional insureds shall provide primary coverage for all claims covered thereby (including as applicable those arising from both ongoing and completed operations) on a non-contributory basis. Contractor shall obtain all necessary endorsements to support these requirements.
- H. *Contractor's professional liability insurance*: If Contractor will provide or furnish professional services under this Contract, through a delegation of professional design services or otherwise, then Contractor shall be responsible for purchasing and maintaining applicable professional liability insurance. This insurance shall provide protection against claims arising out of performance of professional design or related services, and caused by a negligent error, omission, or act for which the insured party is legally liable. It shall be maintained throughout the duration of the Contract and for a minimum of two years after Substantial Completion. If such professional design services are performed by a Subcontractor, and not by Contractor itself, then the requirements of this paragraph may be satisfied through the purchasing and maintenance of such insurance by such Subcontractor.
- I. *General provisions*: The policies of insurance required by this Paragraph 6.03 shall:
1. include at least the specific coverages provided in this Article.
 2. be written for not less than the limits of liability provided in this Article and in the Supplementary Conditions, or required by Laws or Regulations, whichever is greater.
 3. contain a provision or endorsement that the coverage afforded will not be canceled, materially changed, or renewal refused until at least 10 days prior written notice has been given to Contractor. Within three days of receipt of any such written notice, Contractor shall provide a copy of the notice to Owner, Engineer, and each other insured under the policy.
 4. remain in effect at least until final payment (and longer if expressly required in this Article) and at all times thereafter when Contractor may be correcting, removing, or replacing defective Work as a warranty or correction obligation, or otherwise, or returning to the Site to conduct other tasks arising from the Contract Documents.
 5. be appropriate for the Work being performed and provide protection from claims that may arise out of or result from Contractor's performance of the Work and Contractor's other obligations under the Contract Documents, whether it is to be performed by Contractor, any Subcontractor or Supplier, or by anyone directly or indirectly employed by any of them to perform any of the Work, or by anyone for whose acts any of them may be liable.
- J. The coverage requirements for specific policies of insurance must be met by such policies, and not by reference to excess or umbrella insurance provided in other policies.

6.04 *Owner's Liability Insurance*

- A. In addition to the insurance required to be provided by Contractor under Paragraph 6.03, Owner, at Owner's option, may purchase and maintain at Owner's expense Owner's own liability insurance as will protect Owner against claims which may arise from operations under the Contract Documents.
- B. Owner's liability policies, if any, operate separately and independently from policies required to be provided by Contractor, and Contractor cannot rely upon Owner's liability policies for any of Contractor's obligations to the Owner, Engineer, or third parties.

6.05 *Property Insurance*

- A. *Builder's Risk*: Unless otherwise provided in the Supplementary Conditions, Contractor shall purchase and maintain builder's risk insurance upon the Work on a completed value basis, in the amount of the full insurable replacement cost thereof (subject to such deductible amounts as may be provided in the Supplementary Conditions or required by Laws and Regulations). This insurance shall:
 - 1. include the Owner and Contractor as named insureds, and all Subcontractors, and any individuals or entities required by the Supplementary Conditions to be insured under such builder's risk policy, as insureds or named insureds. For purposes of the remainder of this Paragraph 6.05, Paragraphs 6.06 and 6.07, and any corresponding Supplementary Conditions, the parties required to be insured shall collectively be referred to as "insureds."
 - 2. be written on a builder's risk "all risk" policy form that shall at least include insurance for physical loss or damage to the Work, temporary buildings, falsework, and materials and equipment in transit, and shall insure against at least the following perils or causes of loss: fire; lightning; windstorm; riot; civil commotion; terrorism; vehicle impact; aircraft; smoke; theft; vandalism and malicious mischief; mechanical breakdown, boiler explosion, and artificially generated electric current; earthquake; volcanic activity, and other earth movement; flood; collapse; explosion; debris removal; demolition occasioned by enforcement of Laws and Regulations; water damage (other than that caused by flood); and such other perils or causes of loss as may be specifically required by the Supplementary Conditions. If insurance against mechanical breakdown, boiler explosion, and artificially generated electric current; earthquake; volcanic activity, and other earth movement; or flood, are not commercially available under builder's risk policies, by endorsement or otherwise, such insurance may be provided through other insurance policies acceptable to Owner and Contractor.
 - 3. cover, as insured property, at least the following: (a) the Work and all materials, supplies, machinery, apparatus, equipment, fixtures, and other property of a similar nature that are to be incorporated into or used in the preparation, fabrication, construction, erection, or completion of the Work, including Owner-furnished or assigned property; (b) spare parts inventory required within the scope of the Contract; and (c) temporary works which are not intended to form part of the permanent constructed Work but which are intended to provide working access to the Site, or to the Work under construction, or which are intended to provide temporary support for the Work under construction, including scaffolding, form work, fences, shoring, falsework, and temporary structures.
 - 4. cover expenses incurred in the repair or replacement of any insured property (including but not limited to fees and charges of engineers and architects).

5. extend to cover damage or loss to insured property while in temporary storage at the Site or in a storage location outside the Site (but not including property stored at the premises of a manufacturer or Supplier).
 6. extend to cover damage or loss to insured property while in transit.
 7. allow for partial occupation or use of the Work by Owner, such that those portions of the Work that are not yet occupied or used by Owner shall remain covered by the builder's risk insurance.
 8. allow for the waiver of the insurer's subrogation rights, as set forth below.
 9. provide primary coverage for all losses and damages caused by the perils or causes of loss covered.
 10. not include a co-insurance clause.
 11. include an exception for ensuing losses from physical damage or loss with respect to any defective workmanship, design, or materials exclusions.
 12. include performance/hot testing and start-up.
 13. be maintained in effect, subject to the provisions herein regarding Substantial Completion and partial occupancy or use of the Work by Owner, until the Work is complete.
- B. *Notice of Cancellation or Change:* All the policies of insurance (and the certificates or other evidence thereof) required to be purchased and maintained in accordance with this Paragraph 6.05 will contain a provision or endorsement that the coverage afforded will not be canceled or materially changed or renewal refused until at least 10 days prior written notice has been given to the purchasing policyholder. Within three days of receipt of any such written notice, the purchasing policyholder shall provide a copy of the notice to each other insured.
- C. *Deductibles:* The purchaser of any required builder's risk or property insurance shall pay for costs not covered because of the application of a policy deductible.
- D. *Partial Occupancy or Use by Owner:* If Owner will occupy or use a portion or portions of the Work prior to Substantial Completion of all the Work as provided in Paragraph 15.04, then Owner (directly, if it is the purchaser of the builder's risk policy, or through Contractor) will provide notice of such occupancy or use to the builder's risk insurer. The builder's risk insurance shall not be canceled or permitted to lapse on account of any such partial use or occupancy; rather, those portions of the Work that are occupied or used by Owner may come off the builder's risk policy, while those portions of the Work not yet occupied or used by Owner shall remain covered by the builder's risk insurance.
- E. *Additional Insurance:* If Contractor elects to obtain other special insurance to be included in or supplement the builder's risk or property insurance policies provided under this Paragraph 6.05, it may do so at Contractor's expense.
- F. *Insurance of Other Property:* If the express insurance provisions of the Contract do not require or address the insurance of a property item or interest, such as tools, construction equipment, or other personal property owned by Contractor, a Subcontractor, or an employee of Contractor or a Subcontractor, then the entity or individual owning such property item will be responsible for deciding whether to insure it, and if so in what amount.

6.06 *Waiver of Rights*

- A. All policies purchased in accordance with Paragraph 6.05, expressly including the builder's risk policy, shall contain provisions to the effect that in the event of payment of any loss or damage the insurers will have no rights of recovery against any insureds thereunder, or against Engineer or its consultants, or their officers, directors, members, partners, employees, agents, consultants, or subcontractors. Owner and Contractor waive all rights against each other and the respective officers, directors, members, partners, employees, agents, consultants, and subcontractors of each and any of them, for all losses and damages caused by, arising out of, or resulting from any of the perils or causes of loss covered by such policies and any other property insurance applicable to the Work; and, in addition, waive all such rights against Engineer, its consultants, all Subcontractors, all individuals or entities identified in the Supplementary Conditions as insureds, and the officers, directors, members, partners, employees, agents, consultants, and subcontractors of each and any of them, under such policies for losses and damages so caused. None of the above waivers shall extend to the rights that any party making such waiver may have to the proceeds of insurance held by Owner or Contractor as trustee or fiduciary, or otherwise payable under any policy so issued.
- B. Owner waives all rights against Contractor, Subcontractors, and Engineer, and the officers, directors, members, partners, employees, agents, consultants and subcontractors of each and any of them, for:
 - 1. loss due to business interruption, loss of use, or other consequential loss extending beyond direct physical loss or damage to Owner's property or the Work caused by, arising out of, or resulting from fire or other perils whether or not insured by Owner; and
 - 2. loss or damage to the completed Project or part thereof caused by, arising out of, or resulting from fire or other insured peril or cause of loss covered by any property insurance maintained on the completed Project or part thereof by Owner during partial occupancy or use pursuant to Paragraph 15.04, after Substantial Completion pursuant to Paragraph 15.03, or after final payment pursuant to Paragraph 15.06.
- C. Any insurance policy maintained by Owner covering any loss, damage or consequential loss referred to in Paragraph 6.06.B shall contain provisions to the effect that in the event of payment of any such loss, damage, or consequential loss, the insurers will have no rights of recovery against Contractor, Subcontractors, or Engineer, or the officers, directors, members, partners, employees, agents, consultants, or subcontractors of each and any of them.
- D. Contractor shall be responsible for assuring that the agreement under which a Subcontractor performs a portion of the Work contains provisions whereby the Subcontractor waives all rights against Owner, Contractor, all individuals or entities identified in the Supplementary Conditions as insureds, the Engineer and its consultants, and the officers, directors, members, partners, employees, agents, consultants, and subcontractors of each and any of them, for all losses and damages caused by, arising out of, relating to, or resulting from any of the perils or causes of loss covered by builder's risk insurance and any other property insurance applicable to the Work.

6.07 *Receipt and Application of Property Insurance Proceeds*

- A. Any insured loss under the builder's risk and other policies of insurance required by Paragraph 6.05 will be adjusted and settled with the named insured that purchased the

policy. Such named insured shall act as fiduciary for the other insureds, and give notice to such other insureds that adjustment and settlement of a claim is in progress. Any other insured may state its position regarding a claim for insured loss in writing within 15 days after notice of such claim.

- B. Proceeds for such insured losses may be made payable by the insurer either jointly to multiple insureds, or to the named insured that purchased the policy in its own right and as fiduciary for other insureds, subject to the requirements of any applicable mortgage clause. A named insured receiving insurance proceeds under the builder's risk and other policies of insurance required by Paragraph 6.05 shall distribute such proceeds in accordance with such agreement as the parties in interest may reach, or as otherwise required under the dispute resolution provisions of this Contract or applicable Laws and Regulations.
- C. If no other special agreement is reached, the damaged Work shall be repaired or replaced, the money so received applied on account thereof, and the Work and the cost thereof covered by Change Order, if needed.

ARTICLE 7 – CONTRACTOR'S RESPONSIBILITIES

7.01 *Supervision and Superintendence*

- A. Contractor shall supervise, inspect, and direct the Work competently and efficiently, devoting such attention thereto and applying such skills and expertise as may be necessary to perform the Work in accordance with the Contract Documents. Contractor shall be solely responsible for the means, methods, techniques, sequences, and procedures of construction.
- B. At all times during the progress of the Work, Contractor shall assign a competent resident superintendent who shall not be replaced without written notice to Owner and Engineer except under extraordinary circumstances.

7.02 *Labor; Working Hours*

- A. Contractor shall provide competent, suitably qualified personnel to survey and lay out the Work and perform construction as required by the Contract Documents. Contractor shall at all times maintain good discipline and order at the Site.
- B. Except as otherwise required for the safety or protection of persons or the Work or property at the Site or adjacent thereto, and except as otherwise stated in the Contract Documents, all Work at the Site shall be performed during regular working hours, Monday through Friday. Contractor will not perform Work on a Saturday, Sunday, or any legal holiday. Contractor may perform Work outside regular working hours or on Saturdays, Sundays, or legal holidays only with Owner's written consent, which will not be unreasonably withheld.

7.03 *Services, Materials, and Equipment*

- A. Unless otherwise specified in the Contract Documents, Contractor shall provide and assume full responsibility for all services, materials, equipment, labor, transportation, construction equipment and machinery, tools, appliances, fuel, power, light, heat, telephone, water, sanitary facilities, temporary facilities, and all other facilities and incidentals necessary for the performance, testing, start up, and completion of the Work, whether or not such items are specifically called for in the Contract Documents.
- B. All materials and equipment incorporated into the Work shall be of good quality and new, except as otherwise provided in the Contract Documents. All special warranties and

guarantees required by the Specifications shall expressly run to the benefit of Owner. If required by Engineer, Contractor shall furnish satisfactory evidence (including reports of required tests) as to the source, kind, and quality of materials and equipment.

- C. All materials and equipment shall be stored, applied, installed, connected, erected, protected, used, cleaned, and conditioned in accordance with instructions of the applicable Supplier, except as otherwise may be provided in the Contract Documents.

7.04 "Or Equals"

- A. Whenever an item of material or equipment is specified or described in the Contract Documents by using the name of a proprietary item or the name of a particular Supplier, the Contract Price has been based upon Contractor furnishing such item as specified. The specification or description of such an item is intended to establish the type, function, appearance, and quality required. Unless the specification or description contains or is followed by words reading that no like, equivalent, or "or equal" item is permitted, Contractor may request that Engineer authorize the use of other items of material or equipment, or items from other proposed suppliers under the circumstances described below.
 - 1. If Engineer in its sole discretion determines that an item of material or equipment proposed by Contractor is functionally equal to that named and sufficiently similar so that no change in related Work will be required, Engineer shall deem it an "or equal" item. For the purposes of this paragraph, a proposed item of material or equipment will be considered functionally equal to an item so named if:
 - a. in the exercise of reasonable judgment Engineer determines that:
 - 1) it is at least equal in materials of construction, quality, durability, appearance, strength, and design characteristics;
 - 2) it will reliably perform at least equally well the function and achieve the results imposed by the design concept of the completed Project as a functioning whole;
 - 3) it has a proven record of performance and availability of responsive service; and
 - 4) it is not objectionable to Owner.
 - b. Contractor certifies that, if approved and incorporated into the Work:
 - 1) there will be no increase in cost to the Owner or increase in Contract Times; and
 - 2) it will conform substantially to the detailed requirements of the item named in the Contract Documents.
- B. *Contractor's Expense:* Contractor shall provide all data in support of any proposed "or equal" item at Contractor's expense.
- C. *Engineer's Evaluation and Determination:* Engineer will be allowed a reasonable time to evaluate each "or-equal" request. Engineer may require Contractor to furnish additional data about the proposed "or-equal" item. Engineer will be the sole judge of acceptability. No "or-equal" item will be ordered, furnished, installed, or utilized until Engineer's review is complete and Engineer determines that the proposed item is an "or-equal", which will be evidenced by an approved Shop Drawing or other written communication. Engineer will advise Contractor in writing of any negative determination.

- D. *Effect of Engineer's Determination:* Neither approval nor denial of an "or-equal" request shall result in any change in Contract Price. The Engineer's denial of an "or-equal" request shall be final and binding, and may not be reversed through an appeal under any provision of the Contract Documents.
- E. *Treatment as a Substitution Request:* If Engineer determines that an item of material or equipment proposed by Contractor does not qualify as an "or-equal" item, Contractor may request that Engineer considered the proposed item as a substitute pursuant to Paragraph 7.05.

7.05 *Substitutes*

- A. Unless the specification or description of an item of material or equipment required to be furnished under the Contract Documents contains or is followed by words reading that no substitution is permitted, Contractor may request that Engineer authorize the use of other items of material or equipment under the circumstances described below. To the extent possible such requests shall be made before commencement of related construction at the Site.
 - 1. Contractor shall submit sufficient information as provided below to allow Engineer to determine if the item of material or equipment proposed is functionally equivalent to that named and an acceptable substitute therefor. Engineer will not accept requests for review of proposed substitute items of material or equipment from anyone other than Contractor.
 - 2. The requirements for review by Engineer will be as set forth in Paragraph 7.05.B, as supplemented by the Specifications, and as Engineer may decide is appropriate under the circumstances.
 - 3. Contractor shall make written application to Engineer for review of a proposed substitute item of material or equipment that Contractor seeks to furnish or use. The application:
 - a. shall certify that the proposed substitute item will:
 - 1) perform adequately the functions and achieve the results called for by the general design,
 - 2) be similar in substance to that specified, and
 - 3) be suited to the same use as that specified.
 - b. will state:
 - 1) the extent, if any, to which the use of the proposed substitute item will necessitate a change in Contract Times,
 - 2) whether use of the proposed substitute item in the Work will require a change in any of the Contract Documents (or in the provisions of any other direct contract with Owner for other work on the Project) to adapt the design to the proposed substitute item, and
 - 3) whether incorporation or use of the proposed substitute item in connection with the Work is subject to payment of any license fee or royalty.
 - c. will identify:
 - 1) all variations of the proposed substitute item from that specified, and

- 2) available engineering, sales, maintenance, repair, and replacement services.
 - d. shall contain an itemized estimate of all costs or credits that will result directly or indirectly from use of such substitute item, including but not limited to changes in Contract Price, shared savings, costs of redesign, and claims of other contractors affected by any resulting change.
- B. *Engineer's Evaluation and Determination:* Engineer will be allowed a reasonable time to evaluate each substitute request, and to obtain comments and direction from Owner. Engineer may require Contractor to furnish additional data about the proposed substitute item. Engineer will be the sole judge of acceptability. No substitute will be ordered, furnished, installed, or utilized until Engineer's review is complete and Engineer determines that the proposed item is an acceptable substitute. Engineer's determination will be evidenced by a Field Order or a proposed Change Order accounting for the substitution itself and all related impacts, including changes in Contract Price or Contract Times. Engineer will advise Contractor in writing of any negative determination.
 - C. *Special Guarantee:* Owner may require Contractor to furnish at Contractor's expense a special performance guarantee or other surety with respect to any substitute.
 - D. *Reimbursement of Engineer's Cost:* Engineer will record Engineer's costs in evaluating a substitute proposed or submitted by Contractor. Whether or not Engineer approves a substitute so proposed or submitted by Contractor, Contractor shall reimburse Owner for the reasonable charges of Engineer for evaluating each such proposed substitute. Contractor shall also reimburse Owner for the reasonable charges of Engineer for making changes in the Contract Documents (or in the provisions of any other direct contract with Owner) resulting from the acceptance of each proposed substitute.
 - E. *Contractor's Expense:* Contractor shall provide all data in support of any proposed substitute at Contractor's expense.
 - F. *Effect of Engineer's Determination:* If Engineer approves the substitution request, Contractor shall execute the proposed Change Order and proceed with the substitution. The Engineer's denial of a substitution request shall be final and binding, and may not be reversed through an appeal under any provision of the Contract Documents. Contractor may challenge the scope of reimbursement costs imposed under Paragraph 7.05.D, by timely submittal of a Change Proposal.

7.06 *Concerning Subcontractors, Suppliers, and Others*

- A. Contractor may retain Subcontractors and Suppliers for the performance of parts of the Work. Such Subcontractors and Suppliers must be acceptable to Owner.
- B. Contractor shall retain specific Subcontractors, Suppliers, or other individuals or entities for the performance of designated parts of the Work if required by the Contract to do so.
- C. Subsequent to the submittal of Contractor's Bid or final negotiation of the terms of the Contract, Owner may not require Contractor to retain any Subcontractor, Supplier, or other individual or entity to furnish or perform any of the Work against which Contractor has reasonable objection.
- D. Prior to entry into any binding subcontract or purchase order, Contractor shall submit to Owner the identity of the proposed Subcontractor or Supplier (unless Owner has already deemed such proposed Subcontractor or Supplier acceptable, during the bidding process or otherwise). Such proposed Subcontractor or Supplier shall be deemed acceptable to Owner unless Owner raises a substantive, reasonable objection within five days.

- E. Owner may require the replacement of any Subcontractor, Supplier, or other individual or entity retained by Contractor to perform any part of the Work. Owner also may require Contractor to retain specific replacements; provided, however, that Owner may not require a replacement to which Contractor has a reasonable objection. If Contractor has submitted the identity of certain Subcontractors, Suppliers, or other individuals or entities for acceptance by Owner, and Owner has accepted it (either in writing or by failing to make written objection thereto), then Owner may subsequently revoke the acceptance of any such Subcontractor, Supplier, or other individual or entity so identified solely on the basis of substantive, reasonable objection after due investigation. Contractor shall submit an acceptable replacement for the rejected Subcontractor, Supplier, or other individual or entity.
- F. If Owner requires the replacement of any Subcontractor, Supplier, or other individual or entity retained by Contractor to perform any part of the Work, then Contractor shall be entitled to an adjustment in Contract Price or Contract Times, or both, with respect to the replacement; and Contractor shall initiate a Change Proposal for such adjustment within 30 days of Owner's requirement of replacement.
- G. No acceptance by Owner of any such Subcontractor, Supplier, or other individual or entity, whether initially or as a replacement, shall constitute a waiver of the right of Owner to the completion of the Work in accordance with the Contract Documents.
- H. On a monthly basis Contractor shall submit to Engineer a complete list of all Subcontractors and Suppliers having a direct contract with Contractor, and of all other Subcontractors and Suppliers known to Contractor at the time of submittal.
- I. Contractor shall be fully responsible to Owner and Engineer for all acts and omissions of the Subcontractors, Suppliers, and other individuals or entities performing or furnishing any of the Work just as Contractor is responsible for Contractor's own acts and omissions.
- J. Contractor shall be solely responsible for scheduling and coordinating the work of Subcontractors, Suppliers, and all other individuals or entities performing or furnishing any of the Work.
- K. Contractor shall restrict all Subcontractors, Suppliers, and such other individuals or entities performing or furnishing any of the Work from communicating with Engineer or Owner, except through Contractor or in case of an emergency, or as otherwise expressly allowed herein.
- L. The divisions and sections of the Specifications and the identifications of any Drawings shall not control Contractor in dividing the Work among Subcontractors or Suppliers or delineating the Work to be performed by any specific trade.
- M. All Work performed for Contractor by a Subcontractor or Supplier shall be pursuant to an appropriate contractual agreement that specifically binds the Subcontractor or Supplier to the applicable terms and conditions of the Contract Documents for the benefit of Owner and Engineer.
- N. Owner may furnish to any Subcontractor or Supplier, to the extent practicable, information about amounts paid to Contractor on account of Work performed for Contractor by the particular Subcontractor or Supplier.

- O. Nothing in the Contract Documents:
1. shall create for the benefit of any such Subcontractor, Supplier, or other individual or entity any contractual relationship between Owner or Engineer and any such Subcontractor, Supplier, or other individual or entity; nor
 2. shall create any obligation on the part of Owner or Engineer to pay or to see to the payment of any money due any such Subcontractor, Supplier, or other individual or entity except as may otherwise be required by Laws and Regulations.

7.07 *Patent Fees and Royalties*

- A. Contractor shall pay all license fees and royalties and assume all costs incident to the use in the performance of the Work or the incorporation in the Work of any invention, design, process, product, or device which is the subject of patent rights or copyrights held by others. If a particular invention, design, process, product, or device is specified in the Contract Documents for use in the performance of the Work and if, to the actual knowledge of Owner or Engineer, its use is subject to patent rights or copyrights calling for the payment of any license fee or royalty to others, the existence of such rights shall be disclosed by Owner in the Contract Documents.
- B. To the fullest extent permitted by Laws and Regulations, Owner shall indemnify and hold harmless Contractor, and its officers, directors, members, partners, employees, agents, consultants, and subcontractors from and against all claims, costs, losses, and damages (including but not limited to all fees and charges of engineers, architects, attorneys, and other professionals, and all court or arbitration or other dispute resolution costs) arising out of or relating to any infringement of patent rights or copyrights incident to the use in the performance of the Work or resulting from the incorporation in the Work of any invention, design, process, product, or device specified in the Contract Documents, but not identified as being subject to payment of any license fee or royalty to others required by patent rights or copyrights.
- C. To the fullest extent permitted by Laws and Regulations, Contractor shall indemnify and hold harmless Owner and Engineer, and the officers, directors, members, partners, employees, agents, consultants and subcontractors of each and any of them from and against all claims, costs, losses, and damages (including but not limited to all fees and charges of engineers, architects, attorneys, and other professionals and all court or arbitration or other dispute resolution costs) arising out of or relating to any infringement of patent rights or copyrights incident to the use in the performance of the Work or resulting from the incorporation in the Work of any invention, design, process, product, or device not specified in the Contract Documents.

7.08 *Permits*

- A. Unless otherwise provided in the Contract Documents, Contractor shall obtain and pay for all construction permits and licenses. Owner shall assist Contractor, when necessary, in obtaining such permits and licenses. Contractor shall pay all governmental charges and inspection fees necessary for the prosecution of the Work which are applicable at the time of the submission of Contractor's Bid (or when Contractor became bound under a negotiated contract). Owner shall pay all charges of utility owners for connections for providing permanent service to the Work

7.09 *Taxes*

- A. Contractor shall pay all sales, consumer, use, and other similar taxes required to be paid by Contractor in accordance with the Laws and Regulations of the place of the Project which are applicable during the performance of the Work.

7.10 *Laws and Regulations*

- A. Contractor shall give all notices required by and shall comply with all Laws and Regulations applicable to the performance of the Work. Except where otherwise expressly required by applicable Laws and Regulations, neither Owner nor Engineer shall be responsible for monitoring Contractor's compliance with any Laws or Regulations.
- B. If Contractor performs any Work or takes any other action knowing or having reason to know that it is contrary to Laws or Regulations, Contractor shall bear all resulting costs and losses, and shall indemnify and hold harmless Owner and Engineer, and the officers, directors, members, partners, employees, agents, consultants, and subcontractors of each and any of them from and against all claims, costs, losses, and damages (including but not limited to all fees and charges of engineers, architects, attorneys, and other professionals and all court or arbitration or other dispute resolution costs) arising out of or relating to such Work or other action. It shall not be Contractor's responsibility to make certain that the Work described in the Contract Documents is in accordance with Laws and Regulations, but this shall not relieve Contractor of Contractor's obligations under Paragraph 3.03.
- C. Owner or Contractor may give notice to the other party of any changes after the submission of Contractor's Bid (or after the date when Contractor became bound under a negotiated contract) in Laws or Regulations having an effect on the cost or time of performance of the Work, including but not limited to changes in Laws or Regulations having an effect on procuring permits and on sales, use, value-added, consumption, and other similar taxes. If Owner and Contractor are unable to agree on entitlement to or on the amount or extent, if any, of any adjustment in Contract Price or Contract Times resulting from such changes, then within 30 days of such notice Contractor may submit a Change Proposal, or Owner may initiate a Claim.

7.11 *Record Documents*

- A. Contractor shall maintain in a safe place at the Site one printed record copy of all Drawings, Specifications, Addenda, Change Orders, Work Change Directives, Field Orders, written interpretations and clarifications, and approved Shop Drawings. Contractor shall keep such record documents in good order and annotate them to show changes made during construction. These record documents, together with all approved Samples, will be available to Engineer for reference. Upon completion of the Work, Contractor shall deliver these record documents to Engineer.

7.12 *Safety and Protection*

- A. Contractor shall be solely responsible for initiating, maintaining, and supervising all safety precautions and programs in connection with the Work. Such responsibility does not relieve Subcontractors of their responsibility for the safety of persons or property in the performance of their work, nor for compliance with applicable safety Laws and Regulations. Contractor shall take all necessary precautions for the safety of, and shall provide the necessary protection to prevent damage, injury, or loss to:
 - 1. all persons on the Site or who may be affected by the Work;

2. all the Work and materials and equipment to be incorporated therein, whether in storage on or off the Site; and
 3. other property at the Site or adjacent thereto, including trees, shrubs, lawns, walks, pavements, roadways, structures, other work in progress, utilities, and Underground Facilities not designated for removal, relocation, or replacement in the course of construction.
- B. Contractor shall comply with all applicable Laws and Regulations relating to the safety of persons or property, or to the protection of persons or property from damage, injury, or loss; and shall erect and maintain all necessary safeguards for such safety and protection. Contractor shall notify Owner; the owners of adjacent property, Underground Facilities, and other utilities; and other contractors and utility owners performing work at or adjacent to the Site, when prosecution of the Work may affect them, and shall cooperate with them in the protection, removal, relocation, and replacement of their property or work in progress.
 - C. Contractor shall comply with the applicable requirements of Owner's safety programs, if any. The Supplementary Conditions identify any Owner's safety programs that are applicable to the Work.
 - D. Contractor shall inform Owner and Engineer of the specific requirements of Contractor's safety program with which Owner's and Engineer's employees and representatives must comply while at the Site.
 - E. All damage, injury, or loss to any property referred to in Paragraph 7.12.A.2 or 7.12.A.3 caused, directly or indirectly, in whole or in part, by Contractor, any Subcontractor, Supplier, or any other individual or entity directly or indirectly employed by any of them to perform any of the Work, or anyone for whose acts any of them may be liable, shall be remedied by Contractor at its expense (except damage or loss attributable to the fault of Drawings or Specifications or to the acts or omissions of Owner or Engineer or anyone employed by any of them, or anyone for whose acts any of them may be liable, and not attributable, directly or indirectly, in whole or in part, to the fault or negligence of Contractor or any Subcontractor, Supplier, or other individual or entity directly or indirectly employed by any of them).
 - F. Contractor's duties and responsibilities for safety and protection shall continue until such time as all the Work is completed and Engineer has issued a notice to Owner and Contractor in accordance with Paragraph 15.06.B that the Work is acceptable (except as otherwise expressly provided in connection with Substantial Completion).
 - G. Contractor's duties and responsibilities for safety and protection shall resume whenever Contractor or any Subcontractor or Supplier returns to the Site to fulfill warranty or correction obligations, or to conduct other tasks arising from the Contract Documents.

7.13 *Safety Representative*

- A. Contractor shall designate a qualified and experienced safety representative at the Site whose duties and responsibilities shall be the prevention of accidents and the maintaining and supervising of safety precautions and programs.

7.14 *Hazard Communication Programs*

- A. Contractor shall be responsible for coordinating any exchange of material safety data sheets or other hazard communication information required to be made available to or

exchanged between or among employers at the Site in accordance with Laws or Regulations.

7.15 *Emergencies*

- A. In emergencies affecting the safety or protection of persons or the Work or property at the Site or adjacent thereto, Contractor is obligated to act to prevent threatened damage, injury, or loss. Contractor shall give Engineer prompt written notice if Contractor believes that any significant changes in the Work or variations from the Contract Documents have been caused thereby or are required as a result thereof. If Engineer determines that a change in the Contract Documents is required because of the action taken by Contractor in response to such an emergency, a Work Change Directive or Change Order will be issued.

7.16 *Shop Drawings, Samples, and Other Submittals*

A. *Shop Drawing and Sample Submittal Requirements:*

1. Before submitting a Shop Drawing or Sample, Contractor shall have:
 - a. reviewed and coordinated the Shop Drawing or Sample with other Shop Drawings and Samples and with the requirements of the Work and the Contract Documents;
 - b. determined and verified all field measurements, quantities, dimensions, specified performance and design criteria, installation requirements, materials, catalog numbers, and similar information with respect thereto;
 - c. determined and verified the suitability of all materials and equipment offered with respect to the indicated application, fabrication, shipping, handling, storage, assembly, and installation pertaining to the performance of the Work; and
 - d. determined and verified all information relative to Contractor's responsibilities for means, methods, techniques, sequences, and procedures of construction, and safety precautions and programs incident thereto.
2. Each submittal shall bear a stamp or specific written certification that Contractor has satisfied Contractor's obligations under the Contract Documents with respect to Contractor's review of that submittal, and that Contractor approves the submittal.
3. With each submittal, Contractor shall give Engineer specific written notice of any variations that the Shop Drawing or Sample may have from the requirements of the Contract Documents. This notice shall be set forth in a written communication separate from the Shop Drawings or Sample submittal; and, in addition, in the case of Shop Drawings by a specific notation made on each Shop Drawing submitted to Engineer for review and approval of each such variation.

- B. *Submittal Procedures for Shop Drawings and Samples:* Contractor shall submit Shop Drawings and Samples to Engineer for review and approval in accordance with the accepted Schedule of Submittals. Each submittal will be identified as Engineer may require.

1. *Shop Drawings:*

- a. Contractor shall submit the number of copies required in the Specifications.
- b. Data shown on the Shop Drawings will be complete with respect to quantities, dimensions, specified performance and design criteria, materials, and similar data to show Engineer the services, materials, and equipment Contractor proposes to

provide and to enable Engineer to review the information for the limited purposes required by Paragraph 7.16.D.

2. *Samples:*
 - a. Contractor shall submit the number of Samples required in the Specifications.
 - b. Contractor shall clearly identify each Sample as to material, Supplier, pertinent data such as catalog numbers, the use for which intended and other data as Engineer may require to enable Engineer to review the submittal for the limited purposes required by Paragraph 7.16.D.
 3. Where a Shop Drawing or Sample is required by the Contract Documents or the Schedule of Submittals, any related Work performed prior to Engineer's review and approval of the pertinent submittal will be at the sole expense and responsibility of Contractor.
- C. *Other Submittals:* Contractor shall submit other submittals to Engineer in accordance with the accepted Schedule of Submittals, and pursuant to the applicable terms of the Specifications.
- D. *Engineer's Review:*
1. Engineer will provide timely review of Shop Drawings and Samples in accordance with the Schedule of Submittals acceptable to Engineer. Engineer's review and approval will be only to determine if the items covered by the submittals will, after installation or incorporation in the Work, conform to the information given in the Contract Documents and be compatible with the design concept of the completed Project as a functioning whole as indicated by the Contract Documents.
 2. Engineer's review and approval will not extend to means, methods, techniques, sequences, or procedures of construction or to safety precautions or programs incident thereto.
 3. Engineer's review and approval of a separate item as such will not indicate approval of the assembly in which the item functions.
 4. Engineer's review and approval of a Shop Drawing or Sample shall not relieve Contractor from responsibility for any variation from the requirements of the Contract Documents unless Contractor has complied with the requirements of Paragraph 7.16.A.3 and Engineer has given written approval of each such variation by specific written notation thereof incorporated in or accompanying the Shop Drawing or Sample. Engineer will document any such approved variation from the requirements of the Contract Documents in a Field Order.
 5. Engineer's review and approval of a Shop Drawing or Sample shall not relieve Contractor from responsibility for complying with the requirements of Paragraph 7.16.A and B.
 6. Engineer's review and approval of a Shop Drawing or Sample, or of a variation from the requirements of the Contract Documents, shall not, under any circumstances, change the Contract Times or Contract Price, unless such changes are included in a Change Order.
 7. Neither Engineer's receipt, review, acceptance or approval of a Shop Drawing, Sample, or other submittal shall result in such item becoming a Contract Document.

8. Contractor shall perform the Work in compliance with the requirements and commitments set forth in approved Shop Drawings and Samples, subject to the provisions of Paragraph 7.16.D.4.

E. *Resubmittal Procedures:*

1. Contractor shall make corrections required by Engineer and shall return the required number of corrected copies of Shop Drawings and submit, as required, new Samples for review and approval. Contractor shall direct specific attention in writing to revisions other than the corrections called for by Engineer on previous submittals.
2. Contractor shall furnish required submittals with sufficient information and accuracy to obtain required approval of an item with no more than three submittals. Engineer will record Engineer's time for reviewing a fourth or subsequent submittal of a Shop Drawings, sample, or other item requiring approval, and Contractor shall be responsible for Engineer's charges to Owner for such time. Owner may impose a set-off against payments due to Contractor to secure reimbursement for such charges.
3. If Contractor requests a change of a previously approved submittal item, Contractor shall be responsible for Engineer's charges to Owner for its review time, and Owner may impose a set-off against payments due to Contractor to secure reimbursement for such charges, unless the need for such change is beyond the control of Contractor.

7.17 *Contractor's General Warranty and Guarantee*

- A. Contractor warrants and guarantees to Owner that all Work will be in accordance with the Contract Documents and will not be defective. Engineer and its officers, directors, members, partners, employees, agents, consultants, and subcontractors shall be entitled to rely on Contractor's warranty and guarantee.
- B. Contractor's warranty and guarantee hereunder excludes defects or damage caused by:
 1. abuse, modification, or improper maintenance or operation by persons other than Contractor, Subcontractors, Suppliers, or any other individual or entity for whom Contractor is responsible; or
 2. normal wear and tear under normal usage.
- C. Contractor's obligation to perform and complete the Work in accordance with the Contract Documents shall be absolute. None of the following will constitute an acceptance of Work that is not in accordance with the Contract Documents or a release of Contractor's obligation to perform the Work in accordance with the Contract Documents:
 1. observations by Engineer;
 2. recommendation by Engineer or payment by Owner of any progress or final payment;
 3. the issuance of a certificate of Substantial Completion by Engineer or any payment related thereto by Owner;
 4. use or occupancy of the Work or any part thereof by Owner;
 5. any review and approval of a Shop Drawing or Sample submittal;
 6. the issuance of a notice of acceptability by Engineer;
 7. any inspection, test, or approval by others; or
 8. any correction of defective Work by Owner.

- D. If the Contract requires the Contractor to accept the assignment of a contract entered into by Owner, then the specific warranties, guarantees, and correction obligations contained in the assigned contract shall govern with respect to Contractor's performance obligations to Owner for the Work described in the assigned contract.

7.18 *Indemnification*

- A. To the fullest extent permitted by Laws and Regulations, and in addition to any other obligations of Contractor under the Contract or otherwise, Contractor shall indemnify and hold harmless Owner and Engineer, and the officers, directors, members, partners, employees, agents, consultants and subcontractors of each and any of them from and against all claims, costs, losses, and damages (including but not limited to all fees and charges of engineers, architects, attorneys, and other professionals and all court or arbitration or other dispute resolution costs) arising out of or relating to the performance of the Work, provided that any such claim, cost, loss, or damage is attributable to bodily injury, sickness, disease, or death, or to injury to or destruction of tangible property (other than the Work itself), including the loss of use resulting therefrom but only to the extent caused by any negligent act or omission of Contractor, any Subcontractor, any Supplier, or any individual or entity directly or indirectly employed by any of them to perform any of the Work or anyone for whose acts any of them may be liable.
- B. In any and all claims against Owner or Engineer or any of their officers, directors, members, partners, employees, agents, consultants, or subcontractors by any employee (or the survivor or personal representative of such employee) of Contractor, any Subcontractor, any Supplier, or any individual or entity directly or indirectly employed by any of them to perform any of the Work, or anyone for whose acts any of them may be liable, the indemnification obligation under Paragraph 7.18.A shall not be limited in any way by any limitation on the amount or type of damages, compensation, or benefits payable by or for Contractor or any such Subcontractor, Supplier, or other individual or entity under workers' compensation acts, disability benefit acts, or other employee benefit acts.
- C. The indemnification obligations of Contractor under Paragraph 7.18.A shall not extend to the liability of Engineer and Engineer's officers, directors, members, partners, employees, agents, consultants and subcontractors arising out of:
 - 1. the preparation or approval of, or the failure to prepare or approve maps, Drawings, opinions, reports, surveys, Change Orders, designs, or Specifications; or
 - 2. giving directions or instructions, or failing to give them, if that is the primary cause of the injury or damage.

7.19 *Delegation of Professional Design Services*

- A. Contractor will not be required to provide professional design services unless such services are specifically required by the Contract Documents for a portion of the Work or unless such services are required to carry out Contractor's responsibilities for construction means, methods, techniques, sequences and procedures. Contractor shall not be required to provide professional services in violation of applicable Laws and Regulations.
- B. If professional design services or certifications by a design professional related to systems, materials, or equipment are specifically required of Contractor by the Contract Documents, Owner and Engineer will specify all performance and design criteria that such services must satisfy. Contractor shall cause such services or certifications to be provided by a properly licensed professional, whose signature and seal shall appear on all drawings, calculations, specifications, certifications, and other submittals prepared by such professional. Shop

Drawings and other submittals related to the Work designed or certified by such professional, if prepared by others, shall bear such professional's written approval when submitted to Engineer.

- C. Owner and Engineer shall be entitled to rely upon the adequacy, accuracy, and completeness of the services, certifications, or approvals performed by such design professionals, provided Owner and Engineer have specified to Contractor all performance and design criteria that such services must satisfy.
- D. Pursuant to this paragraph, Engineer's review and approval of design calculations and design drawings will be only for the limited purpose of checking for conformance with performance and design criteria given and the design concept expressed in the Contract Documents. Engineer's review and approval of Shop Drawings and other submittals (except design calculations and design drawings) will be only for the purpose stated in Paragraph 7.16.D.1.
- E. Contractor shall not be responsible for the adequacy of the performance or design criteria specified by Owner or Engineer.

ARTICLE 8 – OTHER WORK AT THE SITE

8.01 *Other Work*

- A. In addition to and apart from the Work under the Contract Documents, the Owner may perform other work at or adjacent to the Site. Such other work may be performed by Owner's employees, or through contracts between the Owner and third parties. Owner may also arrange to have third-party utility owners perform work on their utilities and facilities at or adjacent to the Site.
- B. If Owner performs other work at or adjacent to the Site with Owner's employees, or through contracts for such other work, then Owner shall give Contractor written notice thereof prior to starting any such other work. If Owner has advance information regarding the start of any utility work at or adjacent to the Site, Owner shall provide such information to Contractor.
- C. Contractor shall afford each other contractor that performs such other work, each utility owner performing other work, and Owner, if Owner is performing other work with Owner's employees, proper and safe access to the Site, and provide a reasonable opportunity for the introduction and storage of materials and equipment and the execution of such other work. Contractor shall do all cutting, fitting, and patching of the Work that may be required to properly connect or otherwise make its several parts come together and properly integrate with such other work. Contractor shall not endanger any work of others by cutting, excavating, or otherwise altering such work; provided, however, that Contractor may cut or alter others' work with the written consent of Engineer and the others whose work will be affected.
- D. If the proper execution or results of any part of Contractor's Work depends upon work performed by others under this Article 8, Contractor shall inspect such other work and promptly report to Engineer in writing any delays, defects, or deficiencies in such other work that render it unavailable or unsuitable for the proper execution and results of Contractor's Work. Contractor's failure to so report will constitute an acceptance of such other work as fit and proper for integration with Contractor's Work except for latent defects and deficiencies in such other work.

8.02 *Coordination*

- A. If Owner intends to contract with others for the performance of other work at or adjacent to the Site, to perform other work at or adjacent to the Site with Owner's employees, or to arrange to have utility owners perform work at or adjacent to the Site, the following will be set forth in the Supplementary Conditions or provided to Contractor prior to the start of any such other work:
 - 1. the identity of the individual or entity that will have authority and responsibility for coordination of the activities among the various contractors;
 - 2. an itemization of the specific matters to be covered by such authority and responsibility; and
 - 3. the extent of such authority and responsibilities.
- B. Unless otherwise provided in the Supplementary Conditions, Owner shall have sole authority and responsibility for such coordination.

8.03 *Legal Relationships*

- A. If, in the course of performing other work at or adjacent to the Site for Owner, the Owner's employees, any other contractor working for Owner, or any utility owner for whom the Owner is responsible causes damage to the Work or to the property of Contractor or its Subcontractors, or delays, disrupts, interferes with, or increases the scope or cost of the performance of the Work, through actions or inaction, then Contractor shall be entitled to an equitable adjustment in the Contract Price or the Contract Times, or both. Contractor must submit any Change Proposal seeking an equitable adjustment in the Contract Price or the Contract Times under this paragraph within 30 days of the damaging, delaying, disrupting, or interfering event. The entitlement to, and extent of, any such equitable adjustment shall take into account information (if any) regarding such other work that was provided to Contractor in the Contract Documents prior to the submittal of the Bid or the final negotiation of the terms of the Contract. When applicable, any such equitable adjustment in Contract Price shall be conditioned on Contractor assigning to Owner all Contractor's rights against such other contractor or utility owner with respect to the damage, delay, disruption, or interference that is the subject of the adjustment. Contractor's entitlement to an adjustment of the Contract Times is conditioned on such adjustment being essential to Contractor's ability to complete the Work within the Contract Times.
- B. Contractor shall take reasonable and customary measures to avoid damaging, delaying, disrupting, or interfering with the work of Owner, any other contractor, or any utility owner performing other work at or adjacent to the Site. If Contractor fails to take such measures and as a result damages, delays, disrupts, or interferes with the work of any such other contractor or utility owner, then Owner may impose a set-off against payments due to Contractor, and assign to such other contractor or utility owner the Owner's contractual rights against Contractor with respect to the breach of the obligations set forth in this paragraph.
- C. When Owner is performing other work at or adjacent to the Site with Owner's employees, Contractor shall be liable to Owner for damage to such other work, and for the reasonable direct delay, disruption, and interference costs incurred by Owner as a result of Contractor's failure to take reasonable and customary measures with respect to Owner's other work. In response to such damage, delay, disruption, or interference, Owner may impose a set-off against payments due to Contractor.

- D. If Contractor damages, delays, disrupts, or interferes with the work of any other contractor, or any utility owner performing other work at or adjacent to the Site, through Contractor's failure to take reasonable and customary measures to avoid such impacts, or if any claim arising out of Contractor's actions, inactions, or negligence in performance of the Work at or adjacent to the Site is made by any such other contractor or utility owner against Contractor, Owner, or Engineer, then Contractor shall (1) promptly attempt to settle the claim as to all parties through negotiations with such other contractor or utility owner, or otherwise resolve the claim by arbitration or other dispute resolution proceeding or at law, and (2) indemnify and hold harmless Owner and Engineer, and the officers, directors, members, partners, employees, agents, consultants and subcontractors of each and any of them from and against any such claims, and against all costs, losses, and damages (including but not limited to all fees and charges of engineers, architects, attorneys, and other professionals and all court or arbitration or other dispute resolution costs) arising out of or relating to such damage, delay, disruption, or interference.

ARTICLE 9 – OWNER'S RESPONSIBILITIES

9.01 *Communications to Contractor*

- A. Except as otherwise provided in these General Conditions, Owner shall issue all communications to Contractor through Engineer.

9.02 *Replacement of Engineer*

- A. Owner may at its discretion appoint an engineer to replace Engineer, provided Contractor makes no reasonable objection to the replacement engineer. The replacement engineer's status under the Contract Documents shall be that of the former Engineer.

9.03 *Furnish Data*

- A. Owner shall promptly furnish the data required of Owner under the Contract Documents.

9.04 *Pay When Due*

- A. Owner shall make payments to Contractor when they are due as provided in the Agreement.

9.05 *Lands and Easements; Reports, Tests, and Drawings*

- A. Owner's duties with respect to providing lands and easements are set forth in Paragraph 5.01.
- B. Owner's duties with respect to providing engineering surveys to establish reference points are set forth in Paragraph 4.03.
- C. Article 5 refers to Owner's identifying and making available to Contractor copies of reports of explorations and tests of conditions at the Site, and drawings of physical conditions relating to existing surface or subsurface structures at the Site.

9.06 *Insurance*

- A. Owner's responsibilities, if any, with respect to purchasing and maintaining liability and property insurance are set forth in Article 6.

9.07 *Change Orders*

- A. Owner's responsibilities with respect to Change Orders are set forth in Article 11.

9.08 *Inspections, Tests, and Approvals*

- A. Owner's responsibility with respect to certain inspections, tests, and approvals is set forth in Paragraph 14.02.B.

9.09 *Limitations on Owner's Responsibilities*

- A. The Owner shall not supervise, direct, or have control or authority over, nor be responsible for, Contractor's means, methods, techniques, sequences, or procedures of construction, or the safety precautions and programs incident thereto, or for any failure of Contractor to comply with Laws and Regulations applicable to the performance of the Work. Owner will not be responsible for Contractor's failure to perform the Work in accordance with the Contract Documents.

9.10 *Undisclosed Hazardous Environmental Condition*

- A. Owner's responsibility in respect to an undisclosed Hazardous Environmental Condition is set forth in Paragraph 5.06.

9.11 *Evidence of Financial Arrangements*

- A. Upon request of Contractor, Owner shall furnish Contractor reasonable evidence that financial arrangements have been made to satisfy Owner's obligations under the Contract Documents (including obligations under proposed changes in the Work).

9.12 *Safety Programs*

- A. While at the Site, Owner's employees and representatives shall comply with the specific applicable requirements of Contractor's safety programs of which Owner has been informed.
- B. Owner shall furnish copies of any applicable Owner safety programs to Contractor.

ARTICLE 10 – ENGINEER'S STATUS DURING CONSTRUCTION

10.01 *Owner's Representative*

- A. Engineer will be Owner's representative during the construction period. The duties and responsibilities and the limitations of authority of Engineer as Owner's representative during construction are set forth in the Contract.

10.02 *Visits to Site*

- A. Engineer will make visits to the Site at intervals appropriate to the various stages of construction as Engineer deems necessary in order to observe as an experienced and qualified design professional the progress that has been made and the quality of the various aspects of Contractor's executed Work. Based on information obtained during such visits and observations, Engineer, for the benefit of Owner, will determine, in general, if the Work is proceeding in accordance with the Contract Documents. Engineer will not be required to make exhaustive or continuous inspections on the Site to check the quality or quantity of the Work. Engineer's efforts will be directed toward providing for Owner a greater degree of confidence that the completed Work will conform generally to the Contract Documents. On the basis of such visits and observations, Engineer will keep Owner informed of the progress of the Work and will endeavor to guard Owner against defective Work.
- B. Engineer's visits and observations are subject to all the limitations on Engineer's authority and responsibility set forth in Paragraph 10.08. Particularly, but without limitation, during

or as a result of Engineer's visits or observations of Contractor's Work, Engineer will not supervise, direct, control, or have authority over or be responsible for Contractor's means, methods, techniques, sequences, or procedures of construction, or the safety precautions and programs incident thereto, or for any failure of Contractor to comply with Laws and Regulations applicable to the performance of the Work.

10.03 *Project Representative*

- A. If Owner and Engineer have agreed that Engineer will furnish a Resident Project Representative to represent Engineer at the Site and assist Engineer in observing the progress and quality of the Work, then the authority and responsibilities of any such Resident Project Representative will be as provided in the Supplementary Conditions, and limitations on the responsibilities thereof will be as provided in Paragraph 10.08. If Owner designates another representative or agent to represent Owner at the Site who is not Engineer's consultant, agent, or employee, the responsibilities and authority and limitations thereon of such other individual or entity will be as provided in the Supplementary Conditions.

10.04 *Rejecting Defective Work*

- A. Engineer has the authority to reject Work in accordance with Article 14.

10.05 *Shop Drawings, Change Orders and Payments*

- A. Engineer's authority, and limitations thereof, as to Shop Drawings and Samples, are set forth in Paragraph 7.16.
- B. Engineer's authority, and limitations thereof, as to design calculations and design drawings submitted in response to a delegation of professional design services, if any, are set forth in Paragraph 7.19.
- C. Engineer's authority as to Change Orders is set forth in Article 11.
- D. Engineer's authority as to Applications for Payment is set forth in Article 15.

10.06 *Determinations for Unit Price Work*

- A. Engineer will determine the actual quantities and classifications of Unit Price Work performed by Contractor as set forth in Paragraph 13.03.

10.07 *Decisions on Requirements of Contract Documents and Acceptability of Work*

- A. Engineer will render decisions regarding the requirements of the Contract Documents, and judge the acceptability of the Work, pursuant to the specific procedures set forth herein for initial interpretations, Change Proposals, and acceptance of the Work. In rendering such decisions and judgments, Engineer will not show partiality to Owner or Contractor, and will not be liable to Owner, Contractor, or others in connection with any proceedings, interpretations, decisions, or judgments conducted or rendered in good faith.

10.08 *Limitations on Engineer's Authority and Responsibilities*

- A. Neither Engineer's authority or responsibility under this Article 10 or under any other provision of the Contract, nor any decision made by Engineer in good faith either to exercise or not exercise such authority or responsibility or the undertaking, exercise, or performance of any authority or responsibility by Engineer, shall create, impose, or give rise to any duty in contract, tort, or otherwise owed by Engineer to Contractor, any Subcontractor, any Supplier, any other individual or entity, or to any surety for or employee or agent of any of them.

- B. Engineer will not supervise, direct, control, or have authority over or be responsible for Contractor's means, methods, techniques, sequences, or procedures of construction, or the safety precautions and programs incident thereto, or for any failure of Contractor to comply with Laws and Regulations applicable to the performance of the Work. Engineer will not be responsible for Contractor's failure to perform the Work in accordance with the Contract Documents.
- C. Engineer will not be responsible for the acts or omissions of Contractor or of any Subcontractor, any Supplier, or of any other individual or entity performing any of the Work.
- D. Engineer's review of the final Application for Payment and accompanying documentation and all maintenance and operating instructions, schedules, guarantees, bonds, certificates of inspection, tests and approvals, and other documentation required to be delivered by Paragraph 15.06.A will only be to determine generally that their content complies with the requirements of, and in the case of certificates of inspections, tests, and approvals, that the results certified indicate compliance with the Contract Documents.
- E. The limitations upon authority and responsibility set forth in this Paragraph 10.08 shall also apply to the Resident Project Representative, if any.

10.09 *Compliance with Safety Program*

- A. While at the Site, Engineer's employees and representatives will comply with the specific applicable requirements of Owner's and Contractor's safety programs (if any) of which Engineer has been informed.

ARTICLE 11 – AMENDING THE CONTRACT DOCUMENTS; CHANGES IN THE WORK

11.01 *Amending and Supplementing Contract Documents*

- A. The Contract Documents may be amended or supplemented by a Change Order, a Work Change Directive, or a Field Order.
 1. *Change Orders:*
 - a. If an amendment or supplement to the Contract Documents includes a change in the Contract Price or the Contract Times, such amendment or supplement must be set forth in a Change Order. A Change Order also may be used to establish amendments and supplements of the Contract Documents that do not affect the Contract Price or Contract Times.
 - b. Owner and Contractor may amend those terms and conditions of the Contract Documents that do not involve (1) the performance or acceptability of the Work, (2) the design (as set forth in the Drawings, Specifications, or otherwise), or (3) other engineering or technical matters, without the recommendation of the Engineer. Such an amendment shall be set forth in a Change Order.
 2. *Work Change Directives:* A Work Change Directive will not change the Contract Price or the Contract Times but is evidence that the parties expect that the modification ordered or documented by a Work Change Directive will be incorporated in a subsequently issued Change Order, following negotiations by the parties as to the Work Change Directive's effect, if any, on the Contract Price and Contract Times; or, if negotiations are unsuccessful, by a determination under the terms of the Contract Documents governing adjustments, expressly including Paragraph 11.04 regarding change of Contract Price. Contractor must submit any Change Proposal seeking an

adjustment of the Contract Price or the Contract Times, or both, no later than 30 days after the completion of the Work set out in the Work Change Directive. Owner must submit any Claim seeking an adjustment of the Contract Price or the Contract Times, or both, no later than 60 days after issuance of the Work Change Directive.

3. *Field Orders*: Engineer may authorize minor changes in the Work if the changes do not involve an adjustment in the Contract Price or the Contract Times and are compatible with the design concept of the completed Project as a functioning whole as indicated by the Contract Documents. Such changes will be accomplished by a Field Order and will be binding on Owner and also on Contractor, which shall perform the Work involved promptly. If Contractor believes that a Field Order justifies an adjustment in the Contract Price or Contract Times, or both, then before proceeding with the Work at issue, Contractor shall submit a Change Proposal as provided herein.

11.02 *Owner-Authorized Changes in the Work*

- A. Without invalidating the Contract and without notice to any surety, Owner may, at any time or from time to time, order additions, deletions, or revisions in the Work. Such changes shall be supported by Engineer's recommendation, to the extent the change involves the design (as set forth in the Drawings, Specifications, or otherwise), or other engineering or technical matters. Such changes may be accomplished by a Change Order, if Owner and Contractor have agreed as to the effect, if any, of the changes on Contract Times or Contract Price; or by a Work Change Directive. Upon receipt of any such document, Contractor shall promptly proceed with the Work involved; or, in the case of a deletion in the Work, promptly cease construction activities with respect to such deleted Work. Added or revised Work shall be performed under the applicable conditions of the Contract Documents. Nothing in this paragraph shall obligate Contractor to undertake work that Contractor reasonably concludes cannot be performed in a manner consistent with Contractor's safety obligations under the Contract Documents or Laws and Regulations.

11.03 *Unauthorized Changes in the Work*

- A. Contractor shall not be entitled to an increase in the Contract Price or an extension of the Contract Times with respect to any work performed that is not required by the Contract Documents, as amended, modified, or supplemented, except in the case of an emergency as provided in Paragraph 7.15 or in the case of uncovering Work as provided in Paragraph 14.05.

11.04 *Change of Contract Price*

- A. The Contract Price may only be changed by a Change Order. Any Change Proposal for an adjustment in the Contract Price shall comply with the provisions of Paragraph 11.06. Any Claim for an adjustment of Contract Price shall comply with the provisions of Article 12.
- B. An adjustment in the Contract Price will be determined as follows:
 1. where the Work involved is covered by unit prices contained in the Contract Documents, then by application of such unit prices to the quantities of the items involved (subject to the provisions of Paragraph 13.03); or
 2. where the Work involved is not covered by unit prices contained in the Contract Documents, then by a mutually agreed lump sum (which may include an allowance for overhead and profit not necessarily in accordance with Paragraph 11.04.C.2); or
 3. where the Work involved is not covered by unit prices contained in the Contract Documents and the parties do not reach mutual agreement to a lump sum, then on

the basis of the Cost of the Work (determined as provided in Paragraph 13.01) plus a Contractor's fee for overhead and profit (determined as provided in Paragraph 11.04.C).

- C. *Contractor's Fee*: When applicable, the Contractor's fee for overhead and profit shall be determined as follows:
1. a mutually acceptable fixed fee; or
 2. if a fixed fee is not agreed upon, then a fee based on the following percentages of the various portions of the Cost of the Work:
 - a. for costs incurred under Paragraphs 13.01.B.1 and 13.01.B.2, the Contractor's fee shall be 15 percent;
 - b. for costs incurred under Paragraph 13.01.B.3, the Contractor's fee shall be five percent;
 - c. where one or more tiers of subcontracts are on the basis of Cost of the Work plus a fee and no fixed fee is agreed upon, the intent of Paragraphs 11.04.C.2.a and 11.04.C.2.b is that the Contractor's fee shall be based on: (1) a fee of 15 percent of the costs incurred under Paragraphs 13.01.A.1 and 13.01.A.2 by the Subcontractor that actually performs the Work, at whatever tier, and (2) with respect to Contractor itself and to any Subcontractors of a tier higher than that of the Subcontractor that actually performs the Work, a fee of five percent of the amount (fee plus underlying costs incurred) attributable to the next lower tier Subcontractor; provided, however, that for any such subcontracted work the maximum total fee to be paid by Owner shall be no greater than 27 percent of the costs incurred by the Subcontractor that actually performs the work;
 - d. no fee shall be payable on the basis of costs itemized under Paragraphs 13.01.B.4, 13.01.B.5, and 13.01.C;
 - e. the amount of credit to be allowed by Contractor to Owner for any change which results in a net decrease in cost will be the amount of the actual net decrease in cost plus a deduction in Contractor's fee by an amount equal to five percent of such net decrease; and
 - f. when both additions and credits are involved in any one change, the adjustment in Contractor's fee shall be computed on the basis of the net change in accordance with Paragraphs 11.04.C.2.a through 11.04.C.2.e, inclusive.

11.05 *Change of Contract Times*

- A. The Contract Times may only be changed by a Change Order. Any Change Proposal for an adjustment in the Contract Times shall comply with the provisions of Paragraph 11.06. Any Claim for an adjustment in the Contract Times shall comply with the provisions of Article 12.
- B. An adjustment of the Contract Times shall be subject to the limitations set forth in Paragraph 4.05, concerning delays in Contractor's progress.

11.06 *Change Proposals*

- A. Contractor shall submit a Change Proposal to Engineer to request an adjustment in the Contract Times or Contract Price; appeal an initial decision by Engineer concerning the requirements of the Contract Documents or relating to the acceptability of the Work under the Contract Documents; contest a set-off against payment due; or seek other relief under

the Contract. The Change Proposal shall specify any proposed change in Contract Times or Contract Price, or both, or other proposed relief, and explain the reason for the proposed change, with citations to any governing or applicable provisions of the Contract Documents.

1. *Procedures:* Contractor shall submit each Change Proposal to Engineer promptly (but in no event later than 30 days) after the start of the event giving rise thereto, or after such initial decision. The Contractor shall submit supporting data, including the proposed change in Contract Price or Contract Time (if any), to the Engineer and Owner within 15 days after the submittal of the Change Proposal. The supporting data shall be accompanied by a written statement that the supporting data are accurate and complete, and that any requested time or price adjustment is the entire adjustment to which Contractor believes it is entitled as a result of said event. Engineer will advise Owner regarding the Change Proposal, and consider any comments or response from Owner regarding the Change Proposal.
 2. *Engineer's Action:* Engineer will review each Change Proposal and, within 30 days after receipt of the Contractor's supporting data, either deny the Change Proposal in whole, approve it in whole, or deny it in part and approve it in part. Such actions shall be in writing, with a copy provided to Owner and Contractor. If Engineer does not take action on the Change Proposal within 30 days, then either Owner or Contractor may at any time thereafter submit a letter to the other party indicating that as a result of Engineer's inaction the Change Proposal is deemed denied, thereby commencing the time for appeal of the denial under Article 12.
 3. *Binding Decision:* Engineer's decision will be final and binding upon Owner and Contractor, unless Owner or Contractor appeals the decision by filing a Claim under Article 12.
- B. *Resolution of Certain Change Proposals:* If the Change Proposal does not involve the design (as set forth in the Drawings, Specifications, or otherwise), the acceptability of the Work, or other engineering or technical matters, then Engineer will notify the parties that the Engineer is unable to resolve the Change Proposal. For purposes of further resolution of such a Change Proposal, such notice shall be deemed a denial, and Contractor may choose to seek resolution under the terms of Article 12.

11.07 Execution of Change Orders

- A. Owner and Contractor shall execute appropriate Change Orders covering:
1. changes in the Contract Price or Contract Times which are agreed to by the parties, including any undisputed sum or amount of time for Work actually performed in accordance with a Work Change Directive;
 2. changes in Contract Price resulting from an Owner set-off, unless Contractor has duly contested such set-off;
 3. changes in the Work which are: (a) ordered by Owner pursuant to Paragraph 11.02, (b) required because of Owner's acceptance of defective Work under Paragraph 14.04 or Owner's correction of defective Work under Paragraph 14.07, or (c) agreed to by the parties, subject to the need for Engineer's recommendation if the change in the Work involves the design (as set forth in the Drawings, Specifications, or otherwise), or other engineering or technical matters; and
 4. changes in the Contract Price or Contract Times, or other changes, which embody the substance of any final and binding results under Paragraph 11.06, or Article 12.

- B. If Owner or Contractor refuses to execute a Change Order that is required to be executed under the terms of this Paragraph 11.07, it shall be deemed to be of full force and effect, as if fully executed.

11.08 *Notification to Surety*

- A. If the provisions of any bond require notice to be given to a surety of any change affecting the general scope of the Work or the provisions of the Contract Documents (including, but not limited to, Contract Price or Contract Times), the giving of any such notice will be Contractor's responsibility. The amount of each applicable bond will be adjusted to reflect the effect of any such change.

ARTICLE 12 – CLAIMS

12.01 *Claims*

- A. *Claims Process:* The following disputes between Owner and Contractor shall be submitted to the Claims process set forth in this Article:
 - 1. Appeals by Owner or Contractor of Engineer's decisions regarding Change Proposals;
 - 2. Owner demands for adjustments in the Contract Price or Contract Times, or other relief under the Contract Documents; and
 - 3. Disputes that Engineer has been unable to address because they do not involve the design (as set forth in the Drawings, Specifications, or otherwise), the acceptability of the Work, or other engineering or technical matters.
- B. *Submittal of Claim:* The party submitting a Claim shall deliver it directly to the other party to the Contract promptly (but in no event later than 30 days) after the start of the event giving rise thereto; in the case of appeals regarding Change Proposals within 30 days of the decision under appeal. The party submitting the Claim shall also furnish a copy to the Engineer, for its information only. The responsibility to substantiate a Claim shall rest with the party making the Claim. In the case of a Claim by Contractor seeking an increase in the Contract Times or Contract Price, or both, Contractor shall certify that the Claim is made in good faith, that the supporting data are accurate and complete, and that to the best of Contractor's knowledge and belief the amount of time or money requested accurately reflects the full amount to which Contractor is entitled.
- C. *Review and Resolution:* The party receiving a Claim shall review it thoroughly, giving full consideration to its merits. The two parties shall seek to resolve the Claim through the exchange of information and direct negotiations. The parties may extend the time for resolving the Claim by mutual agreement. All actions taken on a Claim shall be stated in writing and submitted to the other party, with a copy to Engineer.
- D. *Mediation:*
 - 1. At any time after initiation of a Claim, Owner and Contractor may mutually agree to mediation of the underlying dispute. The agreement to mediate shall stay the Claim submittal and response process.
 - 2. If Owner and Contractor agree to mediation, then after 60 days from such agreement, either Owner or Contractor may unilaterally terminate the mediation process, and the Claim submittal and decision process shall resume as of the date of the termination. If the mediation proceeds but is unsuccessful in resolving the dispute, the Claim

submittal and decision process shall resume as of the date of the conclusion of the mediation, as determined by the mediator.

3. Owner and Contractor shall each pay one-half of the mediator's fees and costs.
- E. *Partial Approval*: If the party receiving a Claim approves the Claim in part and denies it in part, such action shall be final and binding unless within 30 days of such action the other party invokes the procedure set forth in Article 17 for final resolution of disputes.
- F. *Denial of Claim*: If efforts to resolve a Claim are not successful, the party receiving the Claim may deny it by giving written notice of denial to the other party. If the receiving party does not take action on the Claim within 90 days, then either Owner or Contractor may at any time thereafter submit a letter to the other party indicating that as a result of the inaction, the Claim is deemed denied, thereby commencing the time for appeal of the denial. A denial of the Claim shall be final and binding unless within 30 days of the denial the other party invokes the procedure set forth in Article 17 for the final resolution of disputes.
- G. *Final and Binding Results*: If the parties reach a mutual agreement regarding a Claim, whether through approval of the Claim, direct negotiations, mediation, or otherwise; or if a Claim is approved in part and denied in part, or denied in full, and such actions become final and binding; then the results of the agreement or action on the Claim shall be incorporated in a Change Order to the extent they affect the Contract, including the Work, the Contract Times, or the Contract Price.

ARTICLE 13 – COST OF THE WORK; ALLOWANCES; UNIT PRICE WORK

13.01 *Cost of the Work*

- A. *Purposes for Determination of Cost of the Work*: The term Cost of the Work means the sum of all costs necessary for the proper performance of the Work at issue, as further defined below. The provisions of this Paragraph 13.01 are used for two distinct purposes:
 1. To determine Cost of the Work when Cost of the Work is a component of the Contract Price, under cost-plus-fee, time-and-materials, or other cost-based terms; or
 2. To determine the value of a Change Order, Change Proposal, Claim, set-off, or other adjustment in Contract Price. When the value of any such adjustment is determined on the basis of Cost of the Work, Contractor is entitled only to those additional or incremental costs required because of the change in the Work or because of the event giving rise to the adjustment.
- B. *Costs Included*: Except as otherwise may be agreed to in writing by Owner, costs included in the Cost of the Work shall be in amounts no higher than those prevailing in the locality of the Project, shall not include any of the costs itemized in Paragraph 13.01.C, and shall include only the following items:
 1. Payroll costs for employees in the direct employ of Contractor in the performance of the Work under schedules of job classifications agreed upon by Owner and Contractor. Such employees shall include, without limitation, superintendents, foremen, and other personnel employed full time on the Work. Payroll costs for employees not employed full time on the Work shall be apportioned on the basis of their time spent on the Work. Payroll costs shall include, but not be limited to, salaries and wages plus the cost of fringe benefits, which shall include social security contributions, unemployment, excise, and payroll taxes, workers' compensation, health and retirement benefits, bonuses, sick leave, and vacation and holiday pay applicable

thereto. The expenses of performing Work outside of regular working hours, on Saturday, Sunday, or legal holidays, shall be included in the above to the extent authorized by Owner.

2. Cost of all materials and equipment furnished and incorporated in the Work, including costs of transportation and storage thereof, and Suppliers' field services required in connection therewith. All cash discounts shall accrue to Contractor unless Owner deposits funds with Contractor with which to make payments, in which case the cash discounts shall accrue to Owner. All trade discounts, rebates, and refunds and returns from sale of surplus materials and equipment shall accrue to Owner, and Contractor shall make provisions so that they may be obtained.
3. Payments made by Contractor to Subcontractors for Work performed by Subcontractors. If required by Owner, Contractor shall obtain competitive bids from subcontractors acceptable to Owner and Contractor and shall deliver such bids to Owner, who will then determine, with the advice of Engineer, which bids, if any, will be acceptable. If any subcontract provides that the Subcontractor is to be paid on the basis of Cost of the Work plus a fee, the Subcontractor's Cost of the Work and fee shall be determined in the same manner as Contractor's Cost of the Work and fee as provided in this Paragraph 13.01.
4. Costs of special consultants (including but not limited to engineers, architects, testing laboratories, surveyors, attorneys, and accountants) employed for services specifically related to the Work.
5. Supplemental costs including the following:
 - a. The proportion of necessary transportation, travel, and subsistence expenses of Contractor's employees incurred in discharge of duties connected with the Work.
 - b. Cost, including transportation and maintenance, of all materials, supplies, equipment, machinery, appliances, office, and temporary facilities at the Site, and hand tools not owned by the workers, which are consumed in the performance of the Work, and cost, less market value, of such items used but not consumed which remain the property of Contractor.
 - c. Rentals of all construction equipment and machinery, and the parts thereof, whether rented from Contractor or others in accordance with rental agreements approved by Owner with the advice of Engineer, and the costs of transportation, loading, unloading, assembly, dismantling, and removal thereof. All such costs shall be in accordance with the terms of said rental agreements. The rental of any such equipment, machinery, or parts shall cease when the use thereof is no longer necessary for the Work.
 - d. Sales, consumer, use, and other similar taxes related to the Work, and for which Contractor is liable, as imposed by Laws and Regulations.
 - e. Deposits lost for causes other than negligence of Contractor, any Subcontractor, or anyone directly or indirectly employed by any of them or for whose acts any of them may be liable, and royalty payments and fees for permits and licenses.
 - f. Losses and damages (and related expenses) caused by damage to the Work, not compensated by insurance or otherwise, sustained by Contractor in connection with the performance of the Work (except losses and damages within the deductible amounts of property insurance established in accordance with Paragraph 6.05), provided such losses and damages have resulted from causes

other than the negligence of Contractor, any Subcontractor, or anyone directly or indirectly employed by any of them or for whose acts any of them may be liable. Such losses shall include settlements made with the written consent and approval of Owner. No such losses, damages, and expenses shall be included in the Cost of the Work for the purpose of determining Contractor's fee.

- g. The cost of utilities, fuel, and sanitary facilities at the Site.
- h. Minor expenses such as communication service at the Site, express and courier services, and similar petty cash items in connection with the Work.
- i. The costs of premiums for all bonds and insurance that Contractor is required by the Contract Documents to purchase and maintain.

C. *Costs Excluded:* The term Cost of the Work shall not include any of the following items:

- 1. Payroll costs and other compensation of Contractor's officers, executives, principals (of partnerships and sole proprietorships), general managers, safety managers, engineers, architects, estimators, attorneys, auditors, accountants, purchasing and contracting agents, expeditors, timekeepers, clerks, and other personnel employed by Contractor, whether at the Site or in Contractor's principal or branch office for general administration of the Work and not specifically included in the agreed upon schedule of job classifications referred to in Paragraph 13.01.B.1 or specifically covered by Paragraph 13.01.B.4. The payroll costs and other compensation excluded here are to be considered administrative costs covered by the Contractor's fee.
- 2. Expenses of Contractor's principal and branch offices other than Contractor's office at the Site.
- 3. Any part of Contractor's capital expenses, including interest on Contractor's capital employed for the Work and charges against Contractor for delinquent payments.
- 4. Costs due to the negligence of Contractor, any Subcontractor, or anyone directly or indirectly employed by any of them or for whose acts any of them may be liable, including but not limited to, the correction of defective Work, disposal of materials or equipment wrongly supplied, and making good any damage to property.
- 5. Other overhead or general expense costs of any kind and the costs of any item not specifically and expressly included in Paragraph 13.01.B.

D. *Contractor's Fee:* When the Work as a whole is performed on the basis of cost-plus, Contractor's fee shall be determined as set forth in the Agreement. When the value of any Work covered by a Change Order, Change Proposal, Claim, set-off, or other adjustment in Contract Price is determined on the basis of Cost of the Work, Contractor's fee shall be determined as set forth in Paragraph 11.04.C.

E. *Documentation:* Whenever the Cost of the Work for any purpose is to be determined pursuant to this Article 13, Contractor will establish and maintain records thereof in accordance with generally accepted accounting practices and submit in a form acceptable to Engineer an itemized cost breakdown together with supporting data.

13.02 Allowances

- A. It is understood that Contractor has included in the Contract Price all allowances so named in the Contract Documents and shall cause the Work so covered to be performed for such sums and by such persons or entities as may be acceptable to Owner and Engineer.

- B. *Cash Allowances*: Contractor agrees that:
 - 1. the cash allowances include the cost to Contractor (less any applicable trade discounts) of materials and equipment required by the allowances to be delivered at the Site, and all applicable taxes; and
 - 2. Contractor's costs for unloading and handling on the Site, labor, installation, overhead, profit, and other expenses contemplated for the cash allowances have been included in the Contract Price and not in the allowances, and no demand for additional payment on account of any of the foregoing will be valid.
- C. *Contingency Allowance*: Contractor agrees that a contingency allowance, if any, is for the sole use of Owner to cover unanticipated costs.
- D. Prior to final payment, an appropriate Change Order will be issued as recommended by Engineer to reflect actual amounts due Contractor on account of Work covered by allowances, and the Contract Price shall be correspondingly adjusted.

13.03 *Unit Price Work*

- A. Where the Contract Documents provide that all or part of the Work is to be Unit Price Work, initially the Contract Price will be deemed to include for all Unit Price Work an amount equal to the sum of the unit price for each separately identified item of Unit Price Work times the estimated quantity of each item as indicated in the Agreement.
- B. The estimated quantities of items of Unit Price Work are not guaranteed and are solely for the purpose of comparison of Bids and determining an initial Contract Price. Payments to Contractor for Unit Price Work will be based on actual quantities.
- C. Each unit price will be deemed to include an amount considered by Contractor to be adequate to cover Contractor's overhead and profit for each separately identified item.
- D. Engineer will determine the actual quantities and classifications of Unit Price Work performed by Contractor. Engineer will review with Contractor the Engineer's preliminary determinations on such matters before rendering a written decision thereon (by recommendation of an Application for Payment or otherwise). Engineer's written decision thereon will be final and binding (except as modified by Engineer to reflect changed factual conditions or more accurate data) upon Owner and Contractor, subject to the provisions of the following paragraph.
- E. Within 30 days of Engineer's written decision under the preceding paragraph, Contractor may submit a Change Proposal, or Owner may file a Claim, seeking an adjustment in the Contract Price if:
 - 1. the quantity of any item of Unit Price Work performed by Contractor differs materially and significantly from the estimated quantity of such item indicated in the Agreement;
 - 2. there is no corresponding adjustment with respect to any other item of Work; and
 - 3. Contractor believes that it is entitled to an increase in Contract Price as a result of having incurred additional expense or Owner believes that Owner is entitled to a decrease in Contract Price, and the parties are unable to agree as to the amount of any such increase or decrease.

ARTICLE 14 – TESTS AND INSPECTIONS; CORRECTION, REMOVAL OR ACCEPTANCE OF DEFECTIVE WORK

14.01 Access to Work

- A. Owner, Engineer, their consultants and other representatives and personnel of Owner, independent testing laboratories, and authorities having jurisdiction will have access to the Site and the Work at reasonable times for their observation, inspection, and testing. Contractor shall provide them proper and safe conditions for such access and advise them of Contractor's safety procedures and programs so that they may comply therewith as applicable.

14.02 Tests, Inspections, and Approvals

- A. Contractor shall give Engineer timely notice of readiness of the Work (or specific parts thereof) for all required inspections and tests, and shall cooperate with inspection and testing personnel to facilitate required inspections and tests.
- B. Owner shall retain and pay for the services of an independent inspector, testing laboratory, or other qualified individual or entity to perform all inspections and tests expressly required by the Contract Documents to be furnished and paid for by Owner, except that costs incurred in connection with tests or inspections of covered Work shall be governed by the provisions of Paragraph 14.05.
- C. If Laws or Regulations of any public body having jurisdiction require any Work (or part thereof) specifically to be inspected, tested, or approved by an employee or other representative of such public body, Contractor shall assume full responsibility for arranging and obtaining such inspections, tests, or approvals, pay all costs in connection therewith, and furnish Engineer the required certificates of inspection or approval.
- D. Contractor shall be responsible for arranging, obtaining, and paying for all inspections and tests required:
 - 1. by the Contract Documents, unless the Contract Documents expressly allocate responsibility for a specific inspection or test to Owner;
 - 2. to attain Owner's and Engineer's acceptance of materials or equipment to be incorporated in the Work;
 - 3. by manufacturers of equipment furnished under the Contract Documents;
 - 4. for testing, adjusting, and balancing of mechanical, electrical, and other equipment to be incorporated into the Work; and
 - 5. for acceptance of materials, mix designs, or equipment submitted for approval prior to Contractor's purchase thereof for incorporation in the Work.

Such inspections and tests shall be performed by independent inspectors, testing laboratories, or other qualified individuals or entities acceptable to Owner and Engineer.

- E. If the Contract Documents require the Work (or part thereof) to be approved by Owner, Engineer, or another designated individual or entity, then Contractor shall assume full responsibility for arranging and obtaining such approvals.
- F. If any Work (or the work of others) that is to be inspected, tested, or approved is covered by Contractor without written concurrence of Engineer, Contractor shall, if requested by Engineer, uncover such Work for observation. Such uncovering shall be at Contractor's expense unless Contractor had given Engineer timely notice of Contractor's intention to

cover the same and Engineer had not acted with reasonable promptness in response to such notice.

14.03 *Defective Work*

- A. *Contractor's Obligation:* It is Contractor's obligation to assure that the Work is not defective.
- B. *Engineer's Authority:* Engineer has the authority to determine whether Work is defective, and to reject defective Work.
- C. *Notice of Defects:* Prompt notice of all defective Work of which Owner or Engineer has actual knowledge will be given to Contractor.
- D. *Correction, or Removal and Replacement:* Promptly after receipt of written notice of defective Work, Contractor shall correct all such defective Work, whether or not fabricated, installed, or completed, or, if Engineer has rejected the defective Work, remove it from the Project and replace it with Work that is not defective.
- E. *Preservation of Warranties:* When correcting defective Work, Contractor shall take no action that would void or otherwise impair Owner's special warranty and guarantee, if any, on said Work.
- F. *Costs and Damages:* In addition to its correction, removal, and replacement obligations with respect to defective Work, Contractor shall pay all claims, costs, losses, and damages arising out of or relating to defective Work, including but not limited to the cost of the inspection, testing, correction, removal, replacement, or reconstruction of such defective Work, fines levied against Owner by governmental authorities because the Work is defective, and the costs of repair or replacement of work of others resulting from defective Work. Prior to final payment, if Owner and Contractor are unable to agree as to the measure of such claims, costs, losses, and damages resulting from defective Work, then Owner may impose a reasonable set-off against payments due under Article 15.

14.04 *Acceptance of Defective Work*

- A. If, instead of requiring correction or removal and replacement of defective Work, Owner prefers to accept it, Owner may do so (subject, if such acceptance occurs prior to final payment, to Engineer's confirmation that such acceptance is in general accord with the design intent and applicable engineering principles, and will not endanger public safety). Contractor shall pay all claims, costs, losses, and damages attributable to Owner's evaluation of and determination to accept such defective Work (such costs to be approved by Engineer as to reasonableness), and for the diminished value of the Work to the extent not otherwise paid by Contractor. If any such acceptance occurs prior to final payment, the necessary revisions in the Contract Documents with respect to the Work shall be incorporated in a Change Order. If the parties are unable to agree as to the decrease in the Contract Price, reflecting the diminished value of Work so accepted, then Owner may impose a reasonable set-off against payments due under Article 15. If the acceptance of defective Work occurs after final payment, Contractor shall pay an appropriate amount to Owner.

14.05 *Uncovering Work*

- A. Engineer has the authority to require additional inspection or testing of the Work, whether or not the Work is fabricated, installed, or completed.

- B. If any Work is covered contrary to the written request of Engineer, then Contractor shall, if requested by Engineer, uncover such Work for Engineer's observation, and then replace the covering, all at Contractor's expense.
- C. If Engineer considers it necessary or advisable that covered Work be observed by Engineer or inspected or tested by others, then Contractor, at Engineer's request, shall uncover, expose, or otherwise make available for observation, inspection, or testing as Engineer may require, that portion of the Work in question, and provide all necessary labor, material, and equipment.
 - 1. If it is found that the uncovered Work is defective, Contractor shall be responsible for all claims, costs, losses, and damages arising out of or relating to such uncovering, exposure, observation, inspection, and testing, and of satisfactory replacement or reconstruction (including but not limited to all costs of repair or replacement of work of others); and pending Contractor's full discharge of this responsibility the Owner shall be entitled to impose a reasonable set-off against payments due under Article 15.
 - 2. If the uncovered Work is not found to be defective, Contractor shall be allowed an increase in the Contract Price or an extension of the Contract Times, or both, directly attributable to such uncovering, exposure, observation, inspection, testing, replacement, and reconstruction. If the parties are unable to agree as to the amount or extent thereof, then Contractor may submit a Change Proposal within 30 days of the determination that the Work is not defective.

14.06 *Owner May Stop the Work*

- A. If the Work is defective, or Contractor fails to supply sufficient skilled workers or suitable materials or equipment, or fails to perform the Work in such a way that the completed Work will conform to the Contract Documents, then Owner may order Contractor to stop the Work, or any portion thereof, until the cause for such order has been eliminated; however, this right of Owner to stop the Work shall not give rise to any duty on the part of Owner to exercise this right for the benefit of Contractor, any Subcontractor, any Supplier, any other individual or entity, or any surety for, or employee or agent of any of them.

14.07 *Owner May Correct Defective Work*

- A. If Contractor fails within a reasonable time after written notice from Engineer to correct defective Work, or to remove and replace rejected Work as required by Engineer, or if Contractor fails to perform the Work in accordance with the Contract Documents, or if Contractor fails to comply with any other provision of the Contract Documents, then Owner may, after seven days written notice to Contractor, correct or remedy any such deficiency.
- B. In exercising the rights and remedies under this Paragraph 14.07, Owner shall proceed expeditiously. In connection with such corrective or remedial action, Owner may exclude Contractor from all or part of the Site, take possession of all or part of the Work and suspend Contractor's services related thereto, and incorporate in the Work all materials and equipment stored at the Site or for which Owner has paid Contractor but which are stored elsewhere. Contractor shall allow Owner, Owner's representatives, agents and employees, Owner's other contractors, and Engineer and Engineer's consultants access to the Site to enable Owner to exercise the rights and remedies under this paragraph.
- C. All claims, costs, losses, and damages incurred or sustained by Owner in exercising the rights and remedies under this Paragraph 14.07 will be charged against Contractor as set-offs against payments due under Article 15. Such claims, costs, losses and damages will

include but not be limited to all costs of repair, or replacement of work of others destroyed or damaged by correction, removal, or replacement of Contractor's defective Work.

- D. Contractor shall not be allowed an extension of the Contract Times because of any delay in the performance of the Work attributable to the exercise by Owner of Owner's rights and remedies under this Paragraph 14.07.

ARTICLE 15 – PAYMENTS TO CONTRACTOR; SET-OFFS; COMPLETION; CORRECTION PERIOD

15.01 Progress Payments

- A. *Basis for Progress Payments:* The Schedule of Values established as provided in Article 2 will serve as the basis for progress payments and will be incorporated into a form of Application for Payment acceptable to Engineer. Progress payments on account of Unit Price Work will be based on the number of units completed during the pay period, as determined under the provisions of Paragraph 13.03. Progress payments for cost-based Work will be based on Cost of the Work completed by Contractor during the pay period.
- B. *Applications for Payments:*
1. At least 20 days before the date established in the Agreement for each progress payment (but not more often than once a month), Contractor shall submit to Engineer for review an Application for Payment filled out and signed by Contractor covering the Work completed as of the date of the Application and accompanied by such supporting documentation as is required by the Contract Documents. If payment is requested on the basis of materials and equipment not incorporated in the Work but delivered and suitably stored at the Site or at another location agreed to in writing, the Application for Payment shall also be accompanied by a bill of sale, invoice, or other documentation warranting that Owner has received the materials and equipment free and clear of all Liens, and evidence that the materials and equipment are covered by appropriate property insurance, a warehouse bond, or other arrangements to protect Owner's interest therein, all of which must be satisfactory to Owner.
 2. Beginning with the second Application for Payment, each Application shall include an affidavit of Contractor stating that all previous progress payments received on account of the Work have been applied on account to discharge Contractor's legitimate obligations associated with prior Applications for Payment.
 3. The amount of retainage with respect to progress payments will be as stipulated in the Agreement.
- C. *Review of Applications:*
1. Engineer will, within 10 days after receipt of each Application for Payment, including each resubmittal, either indicate in writing a recommendation of payment and present the Application to Owner, or return the Application to Contractor indicating in writing Engineer's reasons for refusing to recommend payment. In the latter case, Contractor may make the necessary corrections and resubmit the Application.
 2. Engineer's recommendation of any payment requested in an Application for Payment will constitute a representation by Engineer to Owner, based on Engineer's observations of the executed Work as an experienced and qualified design professional, and on Engineer's review of the Application for Payment and the accompanying data and schedules, that to the best of Engineer's knowledge, information and belief:

- a. the Work has progressed to the point indicated;
 - b. the quality of the Work is generally in accordance with the Contract Documents (subject to an evaluation of the Work as a functioning whole prior to or upon Substantial Completion, the results of any subsequent tests called for in the Contract Documents, a final determination of quantities and classifications for Unit Price Work under Paragraph 13.03, and any other qualifications stated in the recommendation); and
 - c. the conditions precedent to Contractor's being entitled to such payment appear to have been fulfilled in so far as it is Engineer's responsibility to observe the Work.
3. By recommending any such payment Engineer will not thereby be deemed to have represented that:
 - a. inspections made to check the quality or the quantity of the Work as it has been performed have been exhaustive, extended to every aspect of the Work in progress, or involved detailed inspections of the Work beyond the responsibilities specifically assigned to Engineer in the Contract; or
 - b. there may not be other matters or issues between the parties that might entitle Contractor to be paid additionally by Owner or entitle Owner to withhold payment to Contractor.
 4. Neither Engineer's review of Contractor's Work for the purposes of recommending payments nor Engineer's recommendation of any payment, including final payment, will impose responsibility on Engineer:
 - a. to supervise, direct, or control the Work, or
 - b. for the means, methods, techniques, sequences, or procedures of construction, or the safety precautions and programs incident thereto, or
 - c. for Contractor's failure to comply with Laws and Regulations applicable to Contractor's performance of the Work, or
 - d. to make any examination to ascertain how or for what purposes Contractor has used the money paid on account of the Contract Price, or
 - e. to determine that title to any of the Work, materials, or equipment has passed to Owner free and clear of any Liens.
 5. Engineer may refuse to recommend the whole or any part of any payment if, in Engineer's opinion, it would be incorrect to make the representations to Owner stated in Paragraph 15.01.C.2.
 6. Engineer will recommend reductions in payment (set-offs) necessary in Engineer's opinion to protect Owner from loss because:
 - a. the Work is defective, requiring correction or replacement;
 - b. the Contract Price has been reduced by Change Orders;
 - c. Owner has been required to correct defective Work in accordance with Paragraph 14.07, or has accepted defective Work pursuant to Paragraph 14.04;
 - d. Owner has been required to remove or remediate a Hazardous Environmental Condition for which Contractor is responsible; or

- e. Engineer has actual knowledge of the occurrence of any of the events that would constitute a default by Contractor and therefore justify termination for cause under the Contract Documents.

D. *Payment Becomes Due:*

- 1. Ten days after presentation of the Application for Payment to Owner with Engineer's recommendation, the amount recommended (subject to any Owner set-offs) will become due, and when due will be paid by Owner to Contractor.

E. *Reductions in Payment by Owner:*

- 1. In addition to any reductions in payment (set-offs) recommended by Engineer, Owner is entitled to impose a set-off against payment based on any of the following:
 - a. claims have been made against Owner on account of Contractor's conduct in the performance or furnishing of the Work, or Owner has incurred costs, losses, or damages on account of Contractor's conduct in the performance or furnishing of the Work, including but not limited to claims, costs, losses, or damages from workplace injuries, adjacent property damage, non-compliance with Laws and Regulations, and patent infringement;
 - b. Contractor has failed to take reasonable and customary measures to avoid damage, delay, disruption, and interference with other work at or adjacent to the Site;
 - c. Contractor has failed to provide and maintain required bonds or insurance;
 - d. Owner has been required to remove or remediate a Hazardous Environmental Condition for which Contractor is responsible;
 - e. Owner has incurred extra charges or engineering costs related to submittal reviews, evaluations of proposed substitutes, tests and inspections, or return visits to manufacturing or assembly facilities;
 - f. the Work is defective, requiring correction or replacement;
 - g. Owner has been required to correct defective Work in accordance with Paragraph 14.07, or has accepted defective Work pursuant to Paragraph 14.04;
 - h. the Contract Price has been reduced by Change Orders;
 - i. an event that would constitute a default by Contractor and therefore justify a termination for cause has occurred;
 - j. liquidated damages have accrued as a result of Contractor's failure to achieve Milestones, Substantial Completion, or final completion of the Work;
 - k. Liens have been filed in connection with the Work, except where Contractor has delivered a specific bond satisfactory to Owner to secure the satisfaction and discharge of such Liens;
 - l. there are other items entitling Owner to a set off against the amount recommended.
- 2. If Owner imposes any set-off against payment, whether based on its own knowledge or on the written recommendations of Engineer, Owner will give Contractor immediate written notice (with a copy to Engineer) stating the reasons for such action and the specific amount of the reduction, and promptly pay Contractor any amount

remaining after deduction of the amount so withheld. Owner shall promptly pay Contractor the amount so withheld, or any adjustment thereto agreed to by Owner and Contractor, if Contractor remedies the reasons for such action. The reduction imposed shall be binding on Contractor unless it duly submits a Change Proposal contesting the reduction.

3. Upon a subsequent determination that Owner's refusal of payment was not justified, the amount wrongfully withheld shall be treated as an amount due as determined by Paragraph 15.01.C.1 and subject to interest as provided in the Agreement.

15.02 *Contractor's Warranty of Title*

- A. Contractor warrants and guarantees that title to all Work, materials, and equipment furnished under the Contract will pass to Owner free and clear of (1) all Liens and other title defects, and (2) all patent, licensing, copyright, or royalty obligations, no later than seven days after the time of payment by Owner.

15.03 *Substantial Completion*

- A. When Contractor considers the entire Work ready for its intended use Contractor shall notify Owner and Engineer in writing that the entire Work is substantially complete and request that Engineer issue a certificate of Substantial Completion. Contractor shall at the same time submit to Owner and Engineer an initial draft of punch list items to be completed or corrected before final payment.
- B. Promptly after Contractor's notification, Owner, Contractor, and Engineer shall make an inspection of the Work to determine the status of completion. If Engineer does not consider the Work substantially complete, Engineer will notify Contractor in writing giving the reasons therefor.
- C. If Engineer considers the Work substantially complete, Engineer will deliver to Owner a preliminary certificate of Substantial Completion which shall fix the date of Substantial Completion. Engineer shall attach to the certificate a punch list of items to be completed or corrected before final payment. Owner shall have seven days after receipt of the preliminary certificate during which to make written objection to Engineer as to any provisions of the certificate or attached punch list. If, after considering the objections to the provisions of the preliminary certificate, Engineer concludes that the Work is not substantially complete, Engineer will, within 14 days after submission of the preliminary certificate to Owner, notify Contractor in writing that the Work is not substantially complete, stating the reasons therefor. If Owner does not object to the provisions of the certificate, or if despite consideration of Owner's objections Engineer concludes that the Work is substantially complete, then Engineer will, within said 14 days, execute and deliver to Owner and Contractor a final certificate of Substantial Completion (with a revised punch list of items to be completed or corrected) reflecting such changes from the preliminary certificate as Engineer believes justified after consideration of any objections from Owner.
- D. At the time of receipt of the preliminary certificate of Substantial Completion, Owner and Contractor will confer regarding Owner's use or occupancy of the Work following Substantial Completion, review the builder's risk insurance policy with respect to the end of the builder's risk coverage, and confirm the transition to coverage of the Work under a permanent property insurance policy held by Owner. Unless Owner and Contractor agree otherwise in writing, Owner shall bear responsibility for security, operation, protection of the Work, property insurance, maintenance, heat, and utilities upon Owner's use or occupancy of the Work.

- E. After Substantial Completion the Contractor shall promptly begin work on the punch list of items to be completed or corrected prior to final payment. In appropriate cases Contractor may submit monthly Applications for Payment for completed punch list items, following the progress payment procedures set forth above.
- F. Owner shall have the right to exclude Contractor from the Site after the date of Substantial Completion subject to allowing Contractor reasonable access to remove its property and complete or correct items on the punch list.

15.04 *Partial Use or Occupancy*

- A. Prior to Substantial Completion of all the Work, Owner may use or occupy any substantially completed part of the Work which has specifically been identified in the Contract Documents, or which Owner, Engineer, and Contractor agree constitutes a separately functioning and usable part of the Work that can be used by Owner for its intended purpose without significant interference with Contractor's performance of the remainder of the Work, subject to the following conditions:
 - 1. At any time Owner may request in writing that Contractor permit Owner to use or occupy any such part of the Work that Owner believes to be substantially complete. If and when Contractor agrees that such part of the Work is substantially complete, Contractor, Owner, and Engineer will follow the procedures of Paragraph 15.03.A through E for that part of the Work.
 - 2. At any time Contractor may notify Owner and Engineer in writing that Contractor considers any such part of the Work substantially complete and request Engineer to issue a certificate of Substantial Completion for that part of the Work.
 - 3. Within a reasonable time after either such request, Owner, Contractor, and Engineer shall make an inspection of that part of the Work to determine its status of completion. If Engineer does not consider that part of the Work to be substantially complete, Engineer will notify Owner and Contractor in writing giving the reasons therefor. If Engineer considers that part of the Work to be substantially complete, the provisions of Paragraph 15.03 will apply with respect to certification of Substantial Completion of that part of the Work and the division of responsibility in respect thereof and access thereto.
 - 4. No use or occupancy or separate operation of part of the Work may occur prior to compliance with the requirements of Paragraph 6.05 regarding builder's risk or other property insurance.

15.05 *Final Inspection*

- A. Upon written notice from Contractor that the entire Work or an agreed portion thereof is complete, Engineer will promptly make a final inspection with Owner and Contractor and will notify Contractor in writing of all particulars in which this inspection reveals that the Work, or agreed portion thereof, is incomplete or defective. Contractor shall immediately take such measures as are necessary to complete such Work or remedy such deficiencies.

15.06 *Final Payment*

- A. *Application for Payment:*
 - 1. After Contractor has, in the opinion of Engineer, satisfactorily completed all corrections identified during the final inspection and has delivered, in accordance with the Contract Documents, all maintenance and operating instructions, schedules, guarantees, bonds, certificates or other evidence of insurance, certificates of

inspection, annotated record documents (as provided in Paragraph 7.11), and other documents, Contractor may make application for final payment.

2. The final Application for Payment shall be accompanied (except as previously delivered) by:
 - a. all documentation called for in the Contract Documents;
 - b. consent of the surety, if any, to final payment;
 - c. satisfactory evidence that all title issues have been resolved such that title to all Work, materials, and equipment has passed to Owner free and clear of any Liens or other title defects, or will so pass upon final payment.
 - d. a list of all disputes that Contractor believes are unsettled; and
 - e. complete and legally effective releases or waivers (satisfactory to Owner) of all Lien rights arising out of the Work, and of Liens filed in connection with the Work.
3. In lieu of the releases or waivers of Liens specified in Paragraph 15.06.A.2 and as approved by Owner, Contractor may furnish receipts or releases in full and an affidavit of Contractor that: (a) the releases and receipts include all labor, services, material, and equipment for which a Lien could be filed; and (b) all payrolls, material and equipment bills, and other indebtedness connected with the Work for which Owner might in any way be responsible, or which might in any way result in liens or other burdens on Owner's property, have been paid or otherwise satisfied. If any Subcontractor or Supplier fails to furnish such a release or receipt in full, Contractor may furnish a bond or other collateral satisfactory to Owner to indemnify Owner against any Lien, or Owner at its option may issue joint checks payable to Contractor and specified Subcontractors and Suppliers.

B. *Engineer's Review of Application and Acceptance:*

1. If, on the basis of Engineer's observation of the Work during construction and final inspection, and Engineer's review of the final Application for Payment and accompanying documentation as required by the Contract Documents, Engineer is satisfied that the Work has been completed and Contractor's other obligations under the Contract have been fulfilled, Engineer will, within ten days after receipt of the final Application for Payment, indicate in writing Engineer's recommendation of final payment and present the Application for Payment to Owner for payment. Such recommendation shall account for any set-offs against payment that are necessary in Engineer's opinion to protect Owner from loss for the reasons stated above with respect to progress payments. At the same time Engineer will also give written notice to Owner and Contractor that the Work is acceptable, subject to the provisions of Paragraph 15.07. Otherwise, Engineer will return the Application for Payment to Contractor, indicating in writing the reasons for refusing to recommend final payment, in which case Contractor shall make the necessary corrections and resubmit the Application for Payment.

C. *Completion of Work:* The Work is complete (subject to surviving obligations) when it is ready for final payment as established by the Engineer's written recommendation of final payment.

D. *Payment Becomes Due:* Thirty days after the presentation to Owner of the final Application for Payment and accompanying documentation, the amount recommended by Engineer (less any further sum Owner is entitled to set off against Engineer's recommendation,

including but not limited to set-offs for liquidated damages and set-offs allowed under the provisions above with respect to progress payments) will become due and shall be paid by Owner to Contractor.

15.07 *Waiver of Claims*

- A. The making of final payment will not constitute a waiver by Owner of claims or rights against Contractor. Owner expressly reserves claims and rights arising from unsettled Liens, from defective Work appearing after final inspection pursuant to Paragraph 15.05, from Contractor's failure to comply with the Contract Documents or the terms of any special guarantees specified therein, from outstanding Claims by Owner, or from Contractor's continuing obligations under the Contract Documents.
- B. The acceptance of final payment by Contractor will constitute a waiver by Contractor of all claims and rights against Owner other than those pending matters that have been duly submitted or appealed under the provisions of Article 17.

15.08 *Correction Period*

- A. If within one year after the date of Substantial Completion (or such longer period of time as may be prescribed by the terms of any applicable special guarantee required by the Contract Documents, or by any specific provision of the Contract Documents), any Work is found to be defective, or if the repair of any damages to the Site, adjacent areas that Contractor has arranged to use through construction easements or otherwise, and other adjacent areas used by Contractor as permitted by Laws and Regulations, is found to be defective, then Contractor shall promptly, without cost to Owner and in accordance with Owner's written instructions:
 - 1. correct the defective repairs to the Site or such other adjacent areas;
 - 2. correct such defective Work;
 - 3. if the defective Work has been rejected by Owner, remove it from the Project and replace it with Work that is not defective, and
 - 4. satisfactorily correct or repair or remove and replace any damage to other Work, to the work of others, or to other land or areas resulting therefrom.
- B. If Contractor does not promptly comply with the terms of Owner's written instructions, or in an emergency where delay would cause serious risk of loss or damage, Owner may have the defective Work corrected or repaired or may have the rejected Work removed and replaced. Contractor shall pay all claims, costs, losses, and damages (including but not limited to all fees and charges of engineers, architects, attorneys, and other professionals and all court or arbitration or other dispute resolution costs) arising out of or relating to such correction or repair or such removal and replacement (including but not limited to all costs of repair or replacement of work of others).
- C. In special circumstances where a particular item of equipment is placed in continuous service before Substantial Completion of all the Work, the correction period for that item may start to run from an earlier date if so provided in the Specifications.
- D. Where defective Work (and damage to other Work resulting therefrom) has been corrected or removed and replaced under this paragraph, the correction period hereunder with respect to such Work will be extended for an additional period of one year after such correction or removal and replacement has been satisfactorily completed.

- E. Contractor's obligations under this paragraph are in addition to all other obligations and warranties. The provisions of this paragraph shall not be construed as a substitute for, or a waiver of, the provisions of any applicable statute of limitation or repose.

ARTICLE 16 – SUSPENSION OF WORK AND TERMINATION

16.01 *Owner May Suspend Work*

- A. At any time and without cause, Owner may suspend the Work or any portion thereof for a period of not more than 90 consecutive days by written notice to Contractor and Engineer. Such notice will fix the date on which Work will be resumed. Contractor shall resume the Work on the date so fixed. Contractor shall be entitled to an adjustment in the Contract Price or an extension of the Contract Times, or both, directly attributable to any such suspension. Any Change Proposal seeking such adjustments shall be submitted no later than 30 days after the date fixed for resumption of Work.

16.02 *Owner May Terminate for Cause*

- A. The occurrence of any one or more of the following events will constitute a default by Contractor and justify termination for cause:
 - 1. Contractor's persistent failure to perform the Work in accordance with the Contract Documents (including, but not limited to, failure to supply sufficient skilled workers or suitable materials or equipment or failure to adhere to the Progress Schedule);
 - 2. Failure of Contractor to perform or otherwise to comply with a material term of the Contract Documents;
 - 3. Contractor's disregard of Laws or Regulations of any public body having jurisdiction; or
 - 4. Contractor's repeated disregard of the authority of Owner or Engineer.
- B. If one or more of the events identified in Paragraph 16.02.A occurs, then after giving Contractor (and any surety) ten days written notice that Owner is considering a declaration that Contractor is in default and termination of the contract, Owner may proceed to:
 - 1. declare Contractor to be in default, and give Contractor (and any surety) notice that the Contract is terminated; and
 - 2. enforce the rights available to Owner under any applicable performance bond.
- C. Subject to the terms and operation of any applicable performance bond, if Owner has terminated the Contract for cause, Owner may exclude Contractor from the Site, take possession of the Work, incorporate in the Work all materials and equipment stored at the Site or for which Owner has paid Contractor but which are stored elsewhere, and complete the Work as Owner may deem expedient.
- D. Owner may not proceed with termination of the Contract under Paragraph 16.02.B if Contractor within seven days of receipt of notice of intent to terminate begins to correct its failure to perform and proceeds diligently to cure such failure.
- E. If Owner proceeds as provided in Paragraph 16.02.B, Contractor shall not be entitled to receive any further payment until the Work is completed. If the unpaid balance of the Contract Price exceeds the cost to complete the Work, including all related claims, costs, losses, and damages (including but not limited to all fees and charges of engineers, architects, attorneys, and other professionals) sustained by Owner, such excess will be paid to Contractor. If the cost to complete the Work including such related claims, costs, losses,

and damages exceeds such unpaid balance, Contractor shall pay the difference to Owner. Such claims, costs, losses, and damages incurred by Owner will be reviewed by Engineer as to their reasonableness and, when so approved by Engineer, incorporated in a Change Order. When exercising any rights or remedies under this paragraph, Owner shall not be required to obtain the lowest price for the Work performed.

- F. Where Contractor's services have been so terminated by Owner, the termination will not affect any rights or remedies of Owner against Contractor then existing or which may thereafter accrue, or any rights or remedies of Owner against Contractor or any surety under any payment bond or performance bond. Any retention or payment of money due Contractor by Owner will not release Contractor from liability.
- G. If and to the extent that Contractor has provided a performance bond under the provisions of Paragraph 6.01.A, the provisions of that bond shall govern over any inconsistent provisions of Paragraphs 16.02.B and 16.02.D.

16.03 *Owner May Terminate For Convenience*

- A. Upon seven days written notice to Contractor and Engineer, Owner may, without cause and without prejudice to any other right or remedy of Owner, terminate the Contract. In such case, Contractor shall be paid for (without duplication of any items):
 - 1. completed and acceptable Work executed in accordance with the Contract Documents prior to the effective date of termination, including fair and reasonable sums for overhead and profit on such Work;
 - 2. expenses sustained prior to the effective date of termination in performing services and furnishing labor, materials, or equipment as required by the Contract Documents in connection with uncompleted Work, plus fair and reasonable sums for overhead and profit on such expenses; and
 - 3. other reasonable expenses directly attributable to termination, including costs incurred to prepare a termination for convenience cost proposal.
- B. Contractor shall not be paid on account of loss of anticipated overhead, profits, or revenue, or other economic loss arising out of or resulting from such termination.

16.04 *Contractor May Stop Work or Terminate*

- A. If, through no act or fault of Contractor, (1) the Work is suspended for more than 90 consecutive days by Owner or under an order of court or other public authority, or (2) Engineer fails to act on any Application for Payment within 30 days after it is submitted, or (3) Owner fails for 30 days to pay Contractor any sum finally determined to be due, then Contractor may, upon seven days written notice to Owner and Engineer, and provided Owner or Engineer do not remedy such suspension or failure within that time, terminate the contract and recover from Owner payment on the same terms as provided in Paragraph 16.03.
- B. In lieu of terminating the Contract and without prejudice to any other right or remedy, if Engineer has failed to act on an Application for Payment within 30 days after it is submitted, or Owner has failed for 30 days to pay Contractor any sum finally determined to be due, Contractor may, seven days after written notice to Owner and Engineer, stop the Work until payment is made of all such amounts due Contractor, including interest thereon. The provisions of this paragraph are not intended to preclude Contractor from submitting a Change Proposal for an adjustment in Contract Price or Contract Times or otherwise for

expenses or damage directly attributable to Contractor's stopping the Work as permitted by this paragraph.

ARTICLE 17 – FINAL RESOLUTION OF DISPUTES

17.01 *Methods and Procedures*

- A. *Disputes Subject to Final Resolution:* The following disputed matters are subject to final resolution under the provisions of this Article:
1. A timely appeal of an approval in part and denial in part of a Claim, or of a denial in full; and
 2. Disputes between Owner and Contractor concerning the Work or obligations under the Contract Documents, and arising after final payment has been made.
- B. *Final Resolution of Disputes:* For any dispute subject to resolution under this Article, Owner or Contractor may:
1. elect in writing to invoke the dispute resolution process provided for in the Supplementary Conditions; or
 2. agree with the other party to submit the dispute to another dispute resolution process; or
 3. if no dispute resolution process is provided for in the Supplementary Conditions or mutually agreed to, give written notice to the other party of the intent to submit the dispute to a court of competent jurisdiction.

ARTICLE 18 – MISCELLANEOUS

18.01 *Giving Notice*

- A. Whenever any provision of the Contract Documents requires the giving of written notice, it will be deemed to have been validly given if:
1. delivered in person, by a commercial courier service or otherwise, to the individual or to a member of the firm or to an officer of the corporation for which it is intended; or
 2. delivered at or sent by registered or certified mail, postage prepaid, to the last business address known to the sender of the notice.

18.02 *Computation of Times*

- A. When any period of time is referred to in the Contract by days, it will be computed to exclude the first and include the last day of such period. If the last day of any such period falls on a Saturday or Sunday or on a day made a legal holiday by the law of the applicable jurisdiction, such day will be omitted from the computation.

18.03 *Cumulative Remedies*

- A. The duties and obligations imposed by these General Conditions and the rights and remedies available hereunder to the parties hereto are in addition to, and are not to be construed in any way as a limitation of, any rights and remedies available to any or all of them which are otherwise imposed or available by Laws or Regulations, by special warranty or guarantee, or by other provisions of the Contract. The provisions of this paragraph will be as effective as if repeated specifically in the Contract Documents in connection with each particular duty, obligation, right, and remedy to which they apply.

18.04 *Limitation of Damages*

- A. With respect to any and all Change Proposals, Claims, disputes subject to final resolution, and other matters at issue, neither Owner nor Engineer, nor any of their officers, directors, members, partners, employees, agents, consultants, or subcontractors, shall be liable to Contractor for any claims, costs, losses, or damages sustained by Contractor on or in connection with any other project or anticipated project.

18.05 *No Waiver*

- A. A party's non-enforcement of any provision shall not constitute a waiver of that provision, nor shall it affect the enforceability of that provision or of the remainder of this Contract.

18.06 *Survival of Obligations*

- A. All representations, indemnifications, warranties, and guarantees made in, required by, or given in accordance with the Contract, as well as all continuing obligations indicated in the Contract, will survive final payment, completion, and acceptance of the Work or termination or completion of the Contract or termination of the services of Contractor.

18.07 *Controlling Law*

- A. This Contract is to be governed by the law of the state in which the Project is located.

18.08 *Headings*

- A. Article and paragraph headings are inserted for convenience only and do not constitute parts of these General Conditions.

SECTION 00 72 10- SUPPLEMENTAL GENERAL CONDITIONS

PART 1 - GENERAL

1.1 COMPLIANCE WITH FEDERAL LAW, REGULATIONS AND EXECUTIVE ORDERS

- A. The recipient and its contractors are required to comply with all Federal laws, regulations, and executive orders. This is an acknowledgement that the Treasury ARP SLFRF financial assistance will be used to fund all or a portion of the contract. The contractor will comply with all applicable Federal law, regulations, executive orders, Treasury policies, procedures, and directives.

1.2 PAYMENT TO CONTRACTOR

- A. To insure the proper performance of this contract, the owner shall retain five percent (5%) of the amount of each estimate until final completion and acceptance of all work covered by this contract: Provided that the Contractor shall submit his estimate not later than the first day of the month: Provided further that on completion and acceptance of each separate building, public work, or other division of the contract, on which the price is stated separately in the contract, payment may be made in full, including retained percentages thereon, less authorized deductions.
- B. In preparing estimates the material delivered on the site and preparatory work done may be taken into consideration.
- C. All material and work covered by partial payments made shall thereupon become the sole property of the Owner, but this provision shall not be construed as relieving the Contractor from the sole responsibility for the care and protection of materials and work upon which payments have been made or the restoration of any damaged work, or as a waiver of the right of the Owner to require the fulfillment of all of the terms of the contract.
- D. Owner's Right to Withhold Certain Amounts and Make Application Thereof: The Contractor agrees that he will indemnify and save the Owner harmless from all claims growing out of the lawful demands of subcontractors, laborers, workers, mechanics, material men, and furnishers of machinery and parts thereof, equipment, power tools, and all supplies, including commissary, incurred in the furtherance of the performance of this contract. The Contractor shall, at the Owner's request, furnish satisfactory evidence that all obligations of the nature hereinabove designated have been paid, discharged, or waived. If the Contractor fails so to do, then the Owner may, after having served written notice on the said Contractor, either pay unpaid bills, of which the Owner has written notice, direct, or withhold from the Contractor's unpaid compensation a sum of money deemed reasonably sufficient to pay any and all such lawful claims until satisfactory evidence is furnished that all liabilities have been fully discharged whereupon payment to the Contractor shall be resumed, in accordance with the terms of this contract, but in no event shall the provisions of this sentence be construed to impose any obligations upon the Owner to either the Contractor or his Surety. In paying any unpaid bills of the Contractor, the Owner shall be deemed the agent of the Contractor, and

any payment so made by the Owner shall be considered as a payment made under the contract by the Owner to the Contractor and the Owner shall not be liable to the Contractor for any such payments made in good faith.

1.3 PAYMENT BY CONTRACTOR

- A. The Contractor shall pay: (a) for all transportation and utility services not later than the 20th day of the calendar month following that in which services are rendered, (b) for all materials, tools, and other expendable equipment to the extent of ninety-five percent (95%) of the cost thereof, not later than the 20th day of the calendar month following that in which such materials, tools, and equipment are delivered at the site of the project, and the balance of the cost thereof, not later than the 30th day following the completion of that equipment are part of the work in or on which such materials, tools, incorporated or used, and (c) to each of his subcontractors, not later than the 5th day following each payment to the Contractor, the respective amounts allowed the Contractor on account of the work performed by his subcontractors to the extent of each subcontractor's interest therein.
- B. Copeland Anti-Kickback Act
 - 1. Contractor. The contractor shall comply with 18 U.S.C. § 874, 40 U.S.C. § 3145, and the requirements of 29 C.F.R. pt. 3 as may be applicable, which are incorporated by reference into this contract.
 - 2. Subcontracts. The contractor or subcontractor shall insert in any subcontracts the clause above and a clause requiring the subcontractors to include these clauses in any lower tier subcontracts. The prime contractor shall be responsible for the compliance by any subcontractor or lower tier subcontractor with all of these contract clauses.
 - 3. Breach. A breach of the contract clauses above may be grounds for termination of the contract, and for debarment as a contractor and subcontractor as provided in 29 C.F.R. § 5.12.”
- C. Procurement of Recovered Materials
 - 1. In the performance of this contract, the Contractor shall make maximum use of products containing recovered materials that are EPA-designated items unless the product cannot be acquired competitively within a timeframe providing for compliance with the contract performance schedule; meeting contract performance requirements; or at a reasonable price.
 - 2. Information about this requirement, along with the list of EPA-designated items, is available at EPA’s Comprehensive Procurement Guidelines webpage: <https://www.epa.gov/smm/comprehensive-procurement-guideline-cpg-program>.
 - 3. The Contractor also agrees to comply with all other applicable requirements of Section 6002 of the Solid Waste Disposal Act.
- D. Domestic Preference for Procurement

1. As appropriate, and to the extent consistent with law, the contractor should, to the greatest extent practicable, provide a preference for the purchase, acquisition, or use of goods, products, or materials produced in the United States. This includes, but is not limited to iron, aluminum, steel, cement, and other manufactured products.
 - a. Produced in the United States means, for iron and steel products, that all manufacturing processes, from the initial melting stage through the application of coatings, occurred in the United States. Manufactured products mean items and construction materials composed in whole or in part of non-ferrous metals such as aluminum; plastics and polymer-based products such as polyvinyl chloride pipe; aggregates such as concrete; glass, including optical fiber; and lumber.

1.4 TIME FOR COMPLETION AND LIQUIDATED DAMAGES

- A. It is hereby understood and mutually agreed, by and between the Contractor and the Owner, that the date of beginning and the time for completion as specified in the contract of the work to be done hereunder are essential conditions of this contract; and it is further mutually understood and agreed that the work embraced in this contract shall be commenced on a date to be specified in the "Notice to Proceed."
- B. The Contractor agrees that said work shall be prosecuted regularly, diligently, and uninterruptedly at such rate of progress as will ensure full completion thereof within the time specified. It is expressly understood and agreed, by and between the Contractor and the Owner, that the time for the completion of the work described herein is a reasonable time for the completion of the same, taking into consideration the average climatic range and usual industrial conditions prevailing in this locality.
- C. If the said Contractor shall neglect, fail or reuse to complete the work within the time herein specified, or any proper extension thereof granted by the Owner, then the Contractor does hereby agree, as a part consideration for the awarding of this contract, not as a penalty but as liquidated damages for such breach of contract as hereinafter set forth, for each and every calendar day that the Contractor shall be in default after the time stipulated in the contract for completing the work.
- D. The said amount is fixed and agreed upon by and between the Contractor and the Owner because of the impracticability and extreme difficulty of fixing and ascertaining the actual damages the Owner would in such event sustain, and said amount is agreed to be the amount of damages which the Owner would sustain and said amount shall be retained from time to time by the Owner from current periodical estimates.
- E. It is further agreed that time is of the essence of each and every portion of this contract and of the specifications wherein a definite and certain length of time is fixed for the performance of any act whatsoever; and where under the contract an additional time is allowed for the completion of any work, the new time limit fixed by such extension shall be of the essence of this contract. Provided that the Contractor shall not be charged with liquidated damages or any excess cost when the Owner determines that the Contractor is without fault and the Contractor's reasons for the time extension are acceptable to the Owner; Provided further that the Contractor shall not be charged with liquidated damages or any excess cost when the delay in completion of the work is due:

1. To any preference, priority or allocation order duly issued by the Government.
2. To unforeseeable cause beyond the control and without the fault or negligence of the Contractor, including, but not restricted to, acts of God, or of the public enemy, acts of the Owner, acts of another Contractor in the performance of a contract with the Owner, fires, floods, epidemics, quarantine restrictions, strikes, freight embargoes, and severe weather: and
3. To any delays of Subcontractors or suppliers occasioned by any of the causes specified in subsections A and B of this article:
 - a. Provided further that the Contractor shall, within ten (10) days from the beginning of such delay, unless the Owner shall grant a further period of time prior to the date of final settlement of the contract, notify the Owner, in writing, of the delay and notify the Contractor within a reasonable time of its decision in the matter.

1.5 PROTECTION OF LIVES AND HEALTH

- A. The Contractor shall exercise proper precaution at all times for the protection of persons and property and shall be responsible for all damages to persons or property, either on or off the site, which occur as a result of his prosecution of the work. The safety provisions of applicable laws and building and construction codes, in addition to specific safety and health regulations described by Chapter XIII, Bureau of Labor Standards, Department of Labor, Part 1518, Safety and Health Regulations for Construction, as outlined in the Federal Register, Volume 36, No. 75, Saturday, April 17, 1971. Title 29 -LABOR, shall be observed and the Contractor shall take or cause to be taken, such additional safety and health measures as the Contracting Authority may determine to be reasonably necessary.
- B. Compliance with the Contract Work Hours and Safety Standards Act.
 1. Overtime requirements. No contractor or subcontractor contracting for any part of the contract work which may require or involve the employment of laborers or mechanics shall require or permit any such laborer or mechanic in any workweek in which he or she is employed on such work to work in excess of forty hours in such workweek unless such laborer or mechanic receives compensation at a rate not less than one and one-half times the basic rate of pay for all hours worked in excess of forty hours in such workweek.
 2. Violation; liability for unpaid wages; liquidated damages. In the event of any violation of the clause set forth in paragraph (b)(1) of this section the contractor and any subcontractor responsible therefore shall be liable for the unpaid wages. In addition, such contractor and subcontractor shall be liable to the United States (in the case of work done under contract for the District of Columbia or a territory, to such District or to such territory), for liquidated damages. Such liquidated damages shall be computed with respect to each individual laborer or mechanic, including watchmen and guards, employed in violation of the clause set forth in paragraph (b)(1) of this section, in the amount of \$27 for each calendar day on which such individual was required or permitted to work in excess of the standard workweek of forty hours without payment of the overtime wages required by the clause set forth in paragraph (b)(1) of this section.

3. Withholding for unpaid wages and liquidated damages. The (write in the name of the Federal agency or the loan or grant recipient) shall upon its own action or upon written request of an authorized representative of the Department of Labor withhold or cause to be withheld, from any moneys payable on account of work performed by the contractor or subcontractor under any such contract or any other Federal contract with the same prime contractor, or any other federally-assisted contract subject to the Contract Work Hours and Safety Standards Act, which is held by the same prime contractor, such sums as may be determined to be necessary to satisfy any liabilities of such contractor or subcontractor for unpaid wages and liquidated damages as provided in the clause set forth in paragraph (b)(2) of this section.
4. Subcontracts. The contractor or subcontractor shall insert in any subcontracts the clauses set forth in paragraphs (b)(1) through (4) of this section and also a clause requiring the subcontractors to include these clauses in any lower-tier subcontracts. The prime contractor shall be responsible for compliance by any subcontractor or lower-tier subcontractor with the clauses set forth in paragraphs (b)(1) through (4) of this section.

C. Clean Air Act

1. The contractor agrees to comply with all applicable standards, orders or regulations issued pursuant to the Clean Air Act, as amended, 42 U.S.C. § 7401 ets eq.
2. The contractor agrees to report each violation to the (name of subrecipient entering the contract) and understands and agrees that the (name of the subrecipient entering into the contract) will, in turn, report each violation as required to assure notification to Treasury, and the appropriate Environmental Protection Agency Regional Office.
3. The contractor agrees to include these requirements in each subcontract exceeding \$150,000.

D. Federal Water Pollution Control Act

1. The contractor agrees to comply with all applicable standards, orders, or regulations issued pursuant to the Federal Water Pollution Control Act, as amended, 33 U.S.C. 1251 ets eq.
2. The contractor agrees to report each violation to the (name of the subrecipient entering the contract) and understands and agrees that the (name of the subrecipient entering into the contract) will, in turn, report each violation as required to assure notification to the Treasury, and the appropriate Environmental Protection Agency Regional Office.
3. The contractor agrees to include these requirements in each subcontract exceeding \$150,000.

1.6 DEBARMENT AND SUSPENSION

- A. This contract is a covered transaction for purposes of 2 C.F.R. pt. 180 and 2 C.F.R. pt. 3000. As such, the contractor is required to verify that none of the contractor's principals (defined at 2 C.F.R. § 180.995) or its affiliates (defined at 2 C.F.R. § 180.905) are excluded (defined at 2 C.F.R. § 180.940) or disqualified (defined at 2 C.F.R. § 180.935).

- B. The contractor must comply with 2 C.F.R. pt. 180, subpart C and 2 C.F.R. pt. 3000, subpart C, and must include a requirement to comply with these regulations in any lower-tier transaction it enters into.
- C. This certification is a material representation of fact relied upon by (insert name of recipient/subrecipient/applicant). If it is later determined that the contractor did not comply with 2 C.F.R. pt. 180, subpart C and 2 C.F.R. pt. 3000, subpart C, in addition to remedies available to (insert name of recipient/subrecipient/applicant), the Federal Government may pursue available remedies, including but not limited to suspension and/or debarment.
- D. The bidder or proposer agrees to comply with the requirements of 2 C.F.R. pt. 180, subpart C and 2 C.F.R. pt. 3000, subpart C while this offer is valid and throughout the period of any contract that may arise from this offer. The bidder or proposer further agrees to include a provision requiring such compliance in its lower tier covered transactions.

1.7 OTHER PROHIBITED INTEREST

- A. No Official of the Owner who is authorized in such capacity and on behalf of the Owner to negotiate, make, accept or approve, or to take part in negotiating, making, accepting, and approving any architectural, engineering, inspection, construction or material supply contract or any subcontract in connection with the construction of the project, shall become directly or indirectly interested personally in this contract or in any part hereof. No officer, employee, architect, attorney, engineer or inspector of or for the Owner who is authorized in such capacity and on behalf of the Owner to exercise any legislative, executive, supervisory or other similar functions in connection with the construction of the project, shall become directly or indirectly interested personally in this contract or in any part thereof, any material supply contract, subcontract, insurance contract, or any other contract pertaining to the project.
- B. During the performance of this contract, the contractor agrees as follows:
 - 1. The contractor will not discriminate against any employee or applicant for employment because of race, color, religion, sex, sexual orientation, gender identity, or national origin. The contractor will take affirmative action to ensure that applicants are employed and that employees are treated during employment without regard to their race, color, religion, sex, sexual orientation, gender identity, or national origin. Such action shall include, but not be limited to the following: Employment, upgrading, demotion, or transfer; recruitment or recruitment advertising; layoff or termination; rates of pay or other forms of compensation; and selection for training, including apprenticeship. The contractor agrees to post in conspicuous places, available to employees and applicants for employment, notices to be provided setting forth the provisions of this nondiscrimination clause.
 - 2. The contractor will, in all solicitations or advertisements for employees placed by or on behalf of the contractor, state that all qualified applicants will receive consideration for employment without regard to race, color, religion, sex, sexual orientation, gender identity, or national origin.
 - 3. The contractor will not discharge or in any other manner discriminate against any employee or applicant for employment because such employee or applicant has inquired about, discussed, or disclosed the compensation of the employee or applicant

or another employee or applicant. This provision shall not apply to instances in which an employee who has access to the compensation information of other employees or applicants as a part of such employee's essential job functions discloses the compensation of such other employees or applicants to individuals who do not otherwise have access to such information, unless such disclosure is in response to a formal complaint or charge, in furtherance of an investigation, proceeding, hearing, or action, including an investigation conducted by the employer, or is consistent with the contractor's legal duty to furnish information.

4. The contractor will send to each labor union or representative of workers with which he has a collective bargaining agreement or other contract or understanding, a notice to be provided advising the said labor union or workers' representatives of the contractor's commitments under this section and shall post copies of the notice in conspicuous places available to employees and applicants for employment.
5. The contractor will comply with all provisions of Executive Order 11246 of September 24, 1965, and of the rules, regulations, and relevant orders of the Secretary of Labor.
6. The contractor will furnish all information and reports required by Executive Order 11246 of September 24, 1965, and by rules, regulations, and orders of the Secretary of Labor, or pursuant thereto, and will permit access to his books, records, and accounts by the administering agency and the Secretary of Labor for purposes of investigation to ascertain compliance with such rules, regulations, and orders.
7. In the event of the contractor's noncompliance with the nondiscrimination clauses of this contract or with any of the said rules, regulations, or orders, this contract may be canceled, terminated, or suspended in whole or in part and the contractor may be declared ineligible for further Government contracts or federally assisted construction contracts in accordance with procedures authorized in Executive Order 11246 of September 24, 1965, and such other sanctions may be imposed and remedies invoked as provided in Executive Order 11246 of September 24, 1965, or by rule, regulation, or order of the Secretary of Labor, or as otherwise provided by law. (8) The contractor will include the portion of the sentence immediately preceding paragraph (1) and the provisions of paragraphs (1) through.
8. In every subcontract or purchase order unless exempted by rules, regulations, or orders of the Secretary of Labor issued pursuant to section 204 of Executive Order 11246 of September 24, 1965, so that such provisions will be binding upon each subcontractor or vendor. The contractor will take such action with respect to any subcontract or purchase order as the administering agency may direct as a means of enforcing such provisions, including sanctions for noncompliance:
 - a. Provided, however, that in the event a contractor becomes involved in, or is threatened with, litigation with a subcontractor or vendor as a result of such direction by the administering agency, the contractor may request the United States to enter into such litigation to protect the interests of the United States.
 - b. The applicant further agrees that it will be bound by the above equal opportunity clause with respect to its own employment practices when it participates in federally assisted construction work: Provided, That if the applicant so participating is a State or local government, the above equal opportunity clause is not applicable to any agency, instrumentality or subdivision of such government which does not participate in work on or under the contract.
 - c. The applicant agrees that it will assist and cooperate actively with the administering agency and the Secretary of Labor in obtaining the compliance of

contractors and subcontractors with the equal opportunity clause and the rules, regulations, and relevant orders of the Secretary of Labor, that it will furnish the administering agency and the Secretary of Labor such information as they may require for the supervision of such compliance, and that it will otherwise assist the administering agency in the discharge of the agency's primary responsibility for securing compliance.

- d. The applicant further agrees that it will refrain from entering into any contract or contract modification subject to Executive Order 11246 of September 24, 1965, with a contractor debarred from, or who has not demonstrated eligibility for, Government contracts and federally assisted construction contracts pursuant to the Executive Order and will carry out such sanctions and penalties for violation of the equal opportunity clause as may be imposed upon contractors and subcontractors by the administering agency or the Secretary of Labor pursuant to Part II, Subpart D of the Executive Order. In addition, the applicant agrees that if it fails or refuses to comply with these undertakings, the administering agency may take any or all of the following actions: Cancel, terminate, or suspend in whole or in part this grant (contract, loan, insurance, guarantee); refrain from extending any further assistance to the applicant under the program with respect to which the failure or refund occurred until satisfactory assurance of future compliance has been received from such applicant; and refer the case to the Department of Justice for appropriate legal proceedings.

C. Byrd Anti-Lobbying Amendment

1. Contractors who apply or bid for an award of \$100,000 or more shall file the required certification. Each tier certifies to the tier above that it will not and has not used Federal appropriated funds to pay any person or organization for influencing or attempting to influence an officer or employee of any agency, a Member of Congress, officer or employee of Congress, or an employee of a Member of Congress in connection with obtaining any Federal contract, grant, or any other award covered by 31 U.S.C. § 1352. Each tier shall also disclose any lobbying with non-Federal funds that takes place in connection with obtaining any Federal award. Such disclosures are forwarded from tier to tier up to the recipient who in turn will forward the certification(s) to the awarding agency.

1.8 MISCELLANEOUS

A. Access to Records

1. The Contractor agrees to provide (insert name of state agency or local or Indian tribal government), (insert name of recipient), Treasury, the Comptroller General of the United States, or any of their authorized representatives access to any books, documents, papers, and records of the Contractor which are directly pertinent to this contract for the purposes of making audits, examinations, excerpts, and transcriptions.
2. The Contractor agrees to permit any of the foregoing parties to reproduce by any means whatsoever or to copy excerpts and transcriptions as reasonably needed.

3. The Contractor agrees to provide the Treasury or authorized representatives access to construction or other work sites pertaining to the work being completed under the contract.
- B. The Contractor acknowledges that 31 U.S.C. Chap. 38 (Administrative Remedies for False Claims and Statements) applies to the Contractor's actions pertaining to this contract.

1.9 USE AND OCCUPANCY PRIOR TO ACCEPTANCE BY OWNER

- A. The Contractor agrees to the use and occupancy of a portion or unit of the project before formal acceptance by the Owner, provided the Owner:
1. Secures written consent of the Contractor except in the event, in the opinion of the Architect/Engineer, the Contractor is chargeable with unwarranted delay in final clean-up of punch list items or other contract requirements.
 2. Secures endorsement from the insurance carrier and consent of the surety permitting occupancy of the building or use of the project during the remaining period of construction, or,
 3. When the project consists of more than one building, and one of the buildings is occupied, secures permanent fire and extended coverage insurance, including a permit to complete construction. Consent of the surety must also be obtained.

1.10 SUSPENSION OF WORK

- A. Should the Owner be prevented or enjoined from proceeding with work either before or after the start of construction by reason of any litigation or other reason beyond the control of the Owner, the Contractor shall not be entitled to make or assert claim for damage by reason of said delay; but time for completion of the work will be extended to such reasonable time as the Owner may determine will compensate for time lost by such delay with such determination to be set forth in writing.

1.11 MATERIAL INSURANCE

- A. The Contractor shall obtain an "Installation Floater" to protect project materials prior to installation. The amount shall be at least One Hundred Percent (100%) of the value of the materials.

1.12 CONTRACTOR'S AND SUBCONTRACTOR'S PUBLIC LIABILITY, VEHICLE LIABILITY, AND PROPERTY DAMAGE INSURANCE

- A. The Contractor agrees to comply with the provisions of the Workman's Compensation Laws of the State in which the work is performed and to require all subcontractors likewise to comply. The Contractor agrees that, prior to the beginning of any work by the Contractor or Subcontractors, as the case may be, the Contractor will furnish to the Owner for himself and for each subcontractor a certificate from insurance company showing issuance of workman's compensation coverage for the State or a certificate from the State Workman's Board showing proof of liability to pay compensation directly.

1.13 EMPLOYER'S PROTECTIVE LIABILITY

- A. Further, the Contractor shall maintain such other insurance (with limits as shown below) to protect the Contractor, the Owner, and the Architect/Engineer from any claims for property damage or personal injury, including death, which may arise out of operations under the Contract. The Contractor shall furnish the Owner certificates and policies of such insurance (as specified below) before the work begins.

- B. Below is listed the additional insurance coverage which shall be procured by the Contractor at his own expense:

1. The Contractor's Public Liability Insurance, Property Damage and Vehicle Liability Insurance shall be in an amount not less than \$1,000,000.00 combined single limits for injuries and property damage, for any one occurrence. There shall also be aggregate limits for injuries and property damage, for any one occurrence. There shall also be an aggregate limit of \$2,000,000.00 and a \$1,000,000.00 "umbrella".
2. Owners Contractors Protective (OCP) shall be provided in the name of the Owner and for a minimum of \$1,000,000.00.
3. The insurance as specified above shall contain a "per project endorsement" such that the above coverage shall apply to this specific project.

- C. ADDITIONAL NAMED INSURED

1. The owner and TLM Associates, Inc. shall be named as additional named insured parties on all contractor liability policies for the project.

1.14 BUILDER'S RISK INSURANCE

General Conditions Article 6.04 *Property Insurance* shall be deleted from the specifications in its entirety.

Builder's Risk is required as specified.

1.15 PERFORMANCE BOND AND PAYMENT BOND

- A. The Contractor shall furnish a Performance Bond and a Labor and Materials Payment Bond in an amount equal to 100% of the Contract Sum as security for the payment of all persons performing labor on the project under this contract and furnishing materials in connection with this contract. Bond shall be furnished through an agent domiciled and legally authorized to do business in the state in which the work is to be performed and delivered to the Owner no later than the date of execution of the contract. Surety Company shall be one acceptable to the Owner and Architect.

1.16 BUSINESS LICENSE

- A. The Contractor shall acquire, at no expense to the Owner, a City and/or County Business License as applicable.

1.17 BUILDING PERMIT

- A. Prior to initiating work, the Contractor shall acquire a permit from the Building Department as applicable.

PART 2 - PRODUCTS

N/A

PART 3 - EXECUTION

N/A

END OF SECTION 00 72 10 - SUPPLEMENTAL GENERAL CONDITIONS

SECTION 00 73 00 – SPECIAL CONDITIONS

1.1 SCOPE OF THE CONTRACT

- A. The work under this Contract includes the furnishing and paying for materials, labor, tools, equipment and other items necessary to construct Town of Hollow Rock Seminary Street Service Line Replacement as herein specified.
- B. Everything necessary for a complete and properly operating installation shall be furnished and installed under this Contract whether or not specifically indicated on the drawings and specified. This is not intended to cover major items of equipment or labor but is intended and will be interpreted to cover all miscellaneous labor, parts, devices, accessories, controls, and appurtenances which are required by all applicable codes, ordinances, laws, and regulations required to complete and place the system in satisfactory operation, and required for a first-class job which is complete in every respect.

1.2 GENERAL

- A. Each Bidder shall carefully examine the site of the work to acquaint himself with working conditions and all difficulties that may be involved and shall carefully examine all Contract Drawings, Specifications, and other contract Documents.
- B. The submission of a Proposal to the Owner shall be accepted as evidence that such examinations have been made, and that all difficulties encountered have been provided for in his Proposal or Bid. Later claims for extra compensation for labor, materials, and equipment which could have been foreseen will not be recognized by the Owner.

1.3 SPECIFICATIONS DIVISIONS AND SECTIONS

- A. Separation of this Specification into Divisions and Sections is for convenience only and is not intended to establish limits of work.
- B. These Special Conditions and the General Conditions shall apply to each and every Division and Section of the Specifications.

1.4 CONFLICTING SPECIFICATIONS

- A. If there is a conflict between specification sections, the order of governance shall be as follows: the Special Conditions shall govern over the Technical Specifications, the General Conditions, and the Supplemental General Conditions. The Supplemental General Conditions shall govern over the Technical Specifications and the General Conditions, and the General Conditions shall govern over the Technical Specifications.

1.5 CODES AND REQUIREMENTS

- A. The Contractor is hereby cautioned that all work on this project shall conform to all local codes that are applicable to this project.
- B. The Contractor is also hereby cautioned that all phases of this project, i.e., equipment, labor, tools, personnel, construction practices, etc., shall conform to the latest O.S.H.A. requirements.

1.6 DEBARRED CONTRACTORS

- A. No award of this Contract shall be made to any firm or individual that is currently debarred by the State of Tennessee or the Federal Highway Administration.

1.7 SUBCONTRACTORS

- A. No subcontractors shall be used on any phase of this project without the express written consent of the Owner and the Engineer.

1.8 ESTIMATED QUANTITIES

- A. Estimated quantities shown in the Plans for items which receive no specific unit price payment (included in other items or paid lump sum) are estimates only. The Contractor shall make his own takeoff of these items as no adjustment in price or payment will be made either up or down for actual quantities that differ from the estimated quantities for these items of work.

1.9 ADJUSTMENT OF UNIT PRICES

- A. No adjustment in Bidder's unit prices shall be made post bid as a result of changes in the cost of materials to the Contractor or an increase/decrease in the actual quantity installed versus the estimated quantity bid.

1.10 ADDITION OR DELETION OF QUANTITIES

- A. The Owner reserves the right to increase or decrease the scope of the project to any extent without causing a breach of contract. Scope changes which do not involve unit price items shall be negotiated to the mutual acceptance of all parties prior to the change taking place.

1.11 TIME FRAME, LIQUIDATED DAMAGES, AND INCENTIVES

- A. By the submission of his bid, the Contractor hereby agrees that "time is of the essence" on this project and that the stipulated liquidated damages will be paid the Owner for delays beyond the stipulated time allowed.

- B. The entirety of the work shall be completed within the specified consecutive calendar days after the issuance of the "Notice to Proceed." Liquidated damages for this work are hereby mutually agreed to be Five Hundred dollars \$500.00 per day for each day completion is delayed beyond the stipulated time.

1.12 ITEMS NOT COVERED IN BID SCHEDULE

- A. No payment shall be made separately or directly for any item which is required by the plans and/or specifications or which can reasonably be inferred there from which is not specifically listed in the Plans and Specifications. All parts of the work or materials not shown but which are necessary to provide a complete and working system are considered to be incidental to the Contract and the Contractor shall include these and their costs in the price for the Project.

1.13 ERRORS AND DISCREPANCIES IN PLANS AND SPECIFICATIONS

- A. Contractor is to verify all dimensions and report any discrepancies to the Engineer before commencing work. The Engineer admits in advance the possibility of errors and discrepancies. These shall be corrected at once upon discovery by the Contractor, subcontractors, material suppliers, or Engineer. If the Contractor does not agree as to the detail methods of construction or use of materials found in the Plans and Specifications, they shall notify the Engineer at once and efforts will be made to coordinate opinions. Otherwise, the work executed from Engineer's Plans and Specifications is guaranteed by Contractor in accordance with "General Conditions of the Contract."
- B. It is the intent of the Owner that all work as shown or specified is to be completed in the manner shown or specified regardless of differences. However, except by Change Order, no increase or decrease in the price of items shall be allowed.

1.14 CONTRACT AWARD

- A. Award will be based upon lowest and best bid as selected by Owner and which best serves the Owner's interest, including alternates, if selected.

1.15 PRE-CONSTRUCTION CONFERENCE

- A. A pre-construction conference will be required prior to the start of construction.
- B. The Contractor shall provide the Engineer with a written work schedule identifying the following information about each line and major equipment installation:
 - 1. Starting date
 - 2. Completion date
 - 3. Date equipment ordered
 - 4. Date equipment received

- C. The schedule shall be revised periodically, upon request by the Engineer, throughout the project to reflect changes from the original projections.

1.16 LINES, GRADES, STAKES, AND TEMPLATES

- A. The Engineer shall provide horizontal and vertical control points for the Contractor's use. The Contractor shall furnish all stakes, templates, patterns, platforms, and labor that may be required in setting and cutting or laying out any part of the work.
- B. The Contractor shall furnish all lines and grades and shall be held responsible for the proper execution of the work to such lines and grades. Benchmarks which are destroyed shall be replaced by the Contractor at his own expense. Run all levels from and to established benchmarks or to the point of beginning for a check. Errors in construction due to failure to run levels properly shall be corrected by the Contractor at his own expense.
- C. Contractor to provide all survey work necessary to determine quantities for the purpose of payment in the manner required by the Engineer.
- D. Construction staking will not be paid for directly; the cost shall be included in the cost of other items of work.

1.17 INDEPENDENT SOILS AND MATERIALS TESTING LABORATORY

- A. The Contractor shall employ and pay for the services of one or more independent soils and materials testing laboratories to perform the quality assurance testing required by the specifications. The Contractor may use his own personnel to prepare concrete cylinders if they are properly certified.
- B. The Contractor shall allow time in his schedule for testing results prior to covering tested work.
- C. No specific payment shall be made for materials testing; the cost shall be included in the cost of other items of work.

1.18 LOCATION OF EXISTING UTILITIES

- A. While the survey attempts to show any known existing utilities, exact numbers, and locations of the various utilities, including services, are unknown. Any location, number, and type of existing utilities shown in the plans are approximate only and not necessarily all that exist. It is the Contractors responsibility to determine exact locations prior to bidding and excavation. No additional compensation will be made for working around utilities and/or locations which are different than that shown in the plans.

1.19 DISPUTE RESOLUTION

- A. Article 16, Dispute Resolution – shall be deleted from the Standard General Conditions of the Construction Contract.

B. It shall be replaced with the following:

1. This Agreement shall be constructed in accordance with the laws of the State of Tennessee. The jurisdiction for any civil action brought pursuant to the Agreement shall lie exclusively in the Chancery Court of the county of the Owner and shall be tried by the Chancellor without the intervention of a jury.

1.20 CONSTRUCTION CLOSE-OUT CONFERENCE

- A. At a time to be designated by the Owner, the Engineer will conduct a construction close-out conference. The Contractor and all subcontractors shall attend this conference. At this time the Contractor shall submit to the Engineer all unresolved items requested for payment for work performed including that of any subcontractors. The Engineer shall make the final determination and qualification of all unresolved items for payment at this conference. The quantities for payment agreed upon at this conference shall be final and shall not be adjusted at a later time.
- B. The close-out conference shall not take the place of the final inspection by the Engineer and the Owner and in no way relieves the Contractor from any directions given by the Engineer during the final inspection.

1.21 RECORD DRAWINGS

- A. The Contractor shall maintain and keep on-site a set of plans and specifications for the sole purpose of marking-up and recording deviations, additions and other required or requested information. The documents shall be turned over to the Engineer at the completion of construction for the purposes of preparing "As-Built" drawings.

1.22 WARRANTY

- A. The Contractor shall, for a period of one (1) year after completion and acceptance of work, repair at his expense any failures.
- B. In the event that the Contractor should fail to make such repairs and adjustments or other similar work, the Owner may do so and charge the Contractor the cost of same.
- C. Upon completion and before final acceptance of project, the Contractor shall furnish the Owner a maintenance bond for the warranty period. In the event the Contractor's Performance Bond covers said warranty period, a certification from Bond Company will be required or the Contractor may elect to have the Owner hold the retainage for the warranty period.

1.23 COOPERATION WITH ENGINEER

- A. The Contractor shall cooperate and coordinate his activities with the Engineer to schedule inspection of the various phases of the work.

1.24 COOPERATION WITH UTILITIES

- A. The Contractor shall cooperate and coordinate his activities with the various utility companies to ensure that existing and/or relocated utilities are not in conflict with the proposed construction. It may be necessary for the Contractor to stake the right-of-way/easement, proposed improvements and/or touchdown line for utility relocation. In addition, all or part of the right-of-way/easement may have to be cleared by the Contractor prior to utility relocation.

1.25 INSPECTION

- A. Whether or not an inspection point is specified herein, all material and workmanship shall be subject to inspection and test at all times and places (including inspection and test after arrival at destination) and, when practicable, during manufacture. In case any articles are found to be defective in material or workmanship, or otherwise not in conformity with the specification requirements, the City shall have the right to reject such articles or require their correction. Final inspection shall be conclusive except as regards latent defects, fraud, or such gross mistakes as amount to fraud. In the event public necessity requires the use of materials or supplies not conforming to the specifications, payment therefore shall be made at a proper reduction in price.

1.26 NOTICE AND SERVICES THEREOF

- A. All notices, demands, requests, instructions, approvals, and claims shall be in writing.
- B. Each notice to or demand upon the Contractor shall be sufficiently given if delivered at the Contractor's office at the address shown by him in the Bid (or at such other office as the Contractor may from time to time designate to the Owner in writing,) or if deposited in the United States mail in a sealed postage-prepaid envelope, or if delivered with charges prepaid to any telegraph company for transmission, in each case addressed to such office.
- C. Unless otherwise specified in writing to the Contractor, all papers required to be delivered to the Owner shall be delivered to the Engineer, and each notice to or demand upon the Owner shall be sufficiently given if delivered to the Engineer's office, or if deposited in the United States mail in a sealed postage-prepaid envelope, or delivered with charges prepaid to any telegraph company for transmission, in each case addressed to the Engineer, or to such other representative of the Owner or to such other address as the Owner may subsequently specify in writing to the Contractor for such purposes.

END OF SECTION 00 73 00

DIVISION 1
GENERAL REQUIREMENTS

SECTION 01 11 00 – SUMMARY OF THE WORK

PART 1 - GENERAL

1.1 The General Conditions, Supplementary General Conditions, and Special Conditions of the Contract are herein made a part of this section of the specifications. The Contractor and Subcontractor shall carefully examine all drawings and all sections of the specifications so as to properly coordinate his work with the work of others.

1.2 WORK COVERED BY CONTRACT DOCUMENTS

- A. The work of this contract comprises of the Hollow Rock Seminary Street Service Line Replacement, including 48 water service lines and curb stops.

1.3 CONTRACTOR'S DUTIES

- A. Except as specifically noted, provide, and pay for labor, materials and equipment, tools, construction equipment and machinery, water, heat, and utilities required for construction, other facilities, and services necessary for proper execution and completion of work.
- B. Pay legally required sales, consumer and use taxes.
- C. Secure and pay for proper execution and completion of work and as applicable at time of receipt of bids, Permits, Government Fees and Licenses.
- D. Give required notices.
- E. Comply with codes, ordinances, rules, regulations, orders, and other legal requirements of public authorities which bear on performance of work.
- F. Promptly submit written notice to Architect of observed variance of Contract Documents from legal requirements. It is not the Contractor's responsibility to make certain that drawings and specifications comply with codes and regulations.
- G. Appropriate modifications to contract documents will adjust necessary changes.
- H. Assume responsibility for work known to be contrary to requirements without notice.
- I. Enforce strict discipline and good order among employees.
- J. Do not employ or work unfit persons or persons not skilled in assigned work.

1.4 CONTRACTS

- A. Construct work under single lump sum or unit price contract as indicated by the Bid Schedule.

1.5 SPECIAL ORDER MATERIALS

- A. The Contractor shall be advised that certain products, materials, and equipment may be available on special order basis only; and he shall place his order for same with the manufacturer early so as not to delay the work.

1.6 CONTRACTOR USE OF PREMISES

- A. Confine operations at site to areas permitted by Law, Ordinances, Permits and Contract Documents.
- B. Do not unreasonably encumber site with materials or equipment.
- C. Do not load structure with weight that will endanger structure.
- D. Assume full responsibility for protection and safekeeping of products stored on premises.
- E. Move any stored products which interfere with operations of Owner or other Contractor.
- F. Obtain and pay for use of additional storage or work areas for needed operations.

1.7 EXAMINATION OF SURFACES

- A. All Contractors shall examine all surfaces on which, or against which, their work is to be applied and shall notify the Architect/Engineer of any defects that in their opinion would be detrimental to the proper installation of their product. Installation of material by the Contractors shall be considered as indication of acceptance of the surface by them.

1.8 COMPLETION

- A. It is the intent of these Specifications/Contract Documents that every fixture, piece of equipment, appliance, and any other related articles shown on the drawings or specified herein, required for the proper completion of the work, shall be completely installed, connected, wired, and made satisfactorily operable for the use for which it is intended. The Manufacturer or Vendor of any fixture and/or equipment shall insure that all connections, mechanical or wired, are properly built-in or attached to the article when it reaches the job site, so it will operate with the connections prepared for it on the project. Notwithstanding any omission or failure on the part of the Manufacturer or Vendor to provide suitable connections, it shall be the responsibility of the Contractor to install and connect such articles.

PART 2 - PRODUCTS

N/A

PART 3 - EXECUTION

N/A

END OF SECTION 01 11 00

SECTION 01 21 46 – WEATHER DELAYS

1.1 EXTENSION OF CONTRACT TIME

If the basis exists for an extension of time in accordance with paragraph 8.3 of the Conditions, an extension of time on the basis of weather may be granted only for the number of Weather Delay Days in excess of the number of days listed as the Standard Baseline for that month.

1.2 STANDARD BASELINE FOR AVERAGE CLIMATIC RANGE

- A. The Owner has reviewed weather data available from the National Oceanic and Atmospheric Administration and determined a Standard Baseline of average climatic range for the State of Tennessee.
- B. Standard Baseline shall be regarded as the normal and anticipatable number of calendar days for each month during which construction activity shall be expected to be prevented and suspended by cause of adverse weather. Suspension of construction activity for the number of days each month as listed in the Standard Baseline is included in the Work and is not eligible for extension of Contract Time.
- C. Standard Baseline is as follows:

| | |
|-----------|----|
| January | 12 |
| February | 11 |
| March | 8 |
| April | 7 |
| May | 7 |
| June | 6 |
| July | 7 |
| August | 5 |
| September | 4 |
| October | 5 |
| November | 6 |
| December | 11 |

1.3 ADVERSE WEATHER AND WEATHER DELAY DAYS

- A. Adverse Weather is defined as the occurrence of one or more of the following conditions which prevents exterior construction activity or access to the site within twenty-four (24) hours:
 - 1. Precipitation (rain, snow, or ice) in excess of one-tenth inch (0.10") liquid measure
 - 2. Temperatures which do not rise above that specified for the day's construction activity by 10:00 a.m., if any is specified.
 - 3. Sustained wind in excess of twenty-five (25) m.p.h.
 - 4. Standing snow in excess of one inch (1.00")

5. Adverse Weather may include, if appropriate, “dry-out” or “mud” days when all the following conditions are met:
 - a. For rain days above the standard baseline.
 - b. Only if there is a hindrance to site access or site work, such as excavation, backfill, and footings.
 - c. At a rate no greater than one (1) make-up day for each day or consecutive days of rain beyond the standard baseline that total 1.0 inch or more, liquid measure, unless specifically recommended otherwise by the Designer.

- B. A Weather Delay Day may be counted if adverse weather prevents work on the project for fifty percent (50%) or more of the Contractor’s scheduled work, including a weekend day or holiday if Contractor has scheduled construction activity that day.

1.4 DOCUMENTATION AND SUBMITTAL

- A. Submit daily jobsite work logs showing which and to what extent construction activities have been affected by weather on a monthly basis.
- B. Submit actual weather data to support claim for time extension obtained from nearest NOAA weather station or other independently verified source approved by Designer at beginning of project.
- C. Use Standard Baseline data provided in this Section when documenting actual delays due to weather in excess of the average climatic range.
- D. Organize claim and documentation to facilitate evaluation on a basis of calendar month periods and submit in accordance with the procedures for claims established in Article 10 of Standard General Conditions of the Construction Contract.
- E. If an extension of the Contract Time is appropriate, it shall be affected in accordance with the provisions of Article 10 of Standard General Conditions of the Construction Contract, and the applicable General Requirements.

END OF SECTION 01 21 46

SECTION 01 26 63 – CHANGE ORDER PROCEDURES

PART 1 - GENERAL

1.1 REQUIREMENTS INCLUDED

- A. Promptly implement change order procedures.
 - 1. Provide full written data required to evaluate changes.
 - 2. Maintain detailed records of work done on a time-and-material/force account basis.
 - 3. Provide full documentation to the Engineer on request.
- B. Designate in writing the member of Contractor's organization:
 - 1. Who is authorized to accept changes in the Work.
 - 2. Who is responsible for informing others in the Contractor's employ of the authorization of changes in the Work.
- C. Owner will designate in writing the person who is authorized to execute Change Orders.

1.2 RELATED REQUIREMENTS

- A. Agreement: The amounts of established unit prices.
- B. Conditions of the Contract:
 - 1. Methods of determining cost or credit to Owner resulting from changes in Work made on a time and material basis.
 - 2. Contractor's claims for additional costs.
- C. Section 01 29 00: Payment Procedures
- D. Section 01 78 39: Project Record Documents

1.3 DEFINITIONS

- A. Change Orders: See General Conditions
- B. Engineer's Supplemental Instructions: A written order, instructions, or interpretations, signed by Engineer making minor changes in the Work not involving a change in Contract Sum or Contract Time.

1.4 PRELIMINARY PROCEDURES

- A. Owner or Engineer may initiate changes by submitting a Proposal Request to Contractor. Request will include:
 - 1. Detailed description of the Change, Products, and location of the change in the Project.
 - 2. Supplementary or revised Drawings and Specifications.
 - 3. The projected time span for making the change, and a specific statement as to whether overtime work is, or is not, authorized.
 - 4. A specified period of time during which the requested price will be considered valid.
 - 5. Such request is for information only, and is not an instruction to execute the changes, nor to stop Work in progress.

- B. On request, provide additional data to support time and cost computations:
 - 1. Labor required.
 - 2. Equipment required.
 - 3. Products required:
 - a. Recommended source of purchase and unit cost.
 - b. Quantities required.
 - 4. Taxes, insurance, and bonds.
 - 5. Credit for work deleted from Contract, similarly documented.
 - 6. Overhead and profit.
 - 7. Justification for any change in Contract Time.

- C. Support each claim for additional costs, and for work done on a time-and-material/force account basis, with documentation as required for a lump-sum proposal, plus additional information.
 - 1. Name of the Owner's authorized agent who ordered the work, and date on the order.
 - 2. Dates and times work was performed, and by whom.
 - 3. Time record, summary of hours worked, and hourly rates paid.
 - 4. Receipts and invoices for:
 - a. Equipment used, listing dates and times of use.
 - b. Products used, listing of quantities.
 - c. Subcontracts.

1.5 PREPARATION OF CHANGE ORDERS

- A. Engineer will prepare each Change Order.

- B. Form: Change order: EJCDC C-941 or other approved equal.

- C. Change Order will describe changes in the Work, both deletions, with attachments of revised Contract Documents to define details of the change.

- D. Change Order will provide an accounting of the adjustment in the Contract Sum and in the Contract Time.

1.6 LUMP-SUM/FIXED PRICE CHANGE ORDER

- A. Content of Change Orders will be based on, either:
 - 1. Engineer's Proposal Request and Contractor's responsive Proposal as mutually agreed between Owner and Contractor.
 - 2. Contractor's Proposal for a change, as recommended by Engineer.
- B. Owner and Engineer will sign and date the Change Order as authorization for the Contractor to proceed with the changes.
- C. Contractor may sign and date the Change Order to indicate agreement with the terms therein.

1.7 UNIT PRICE CHANGE ORDER

- A. Content of Change Orders will be based on, either:
 - 1. Engineer's definition of the scope of the required changes.
 - 2. Contractor's Proposal for a change, as recommended by Engineer.
 - 3. Survey of complete work.
- B. The amount of the unit prices to be:
 - 1. Those stated in the Agreement.
 - 2. Those mutually agreed upon between Owner and Contractor.
- C. When quantities of each of the items affected by the Change Order can be determined prior to start of the work:
 - 1. Owner and Engineer will sign and date the Change Order as authorization for Contractor to proceed with the changes.
 - 2. Contractor may sign and date the Change Order to indicate agreement with the terms therein.
- D. When quantities of the items cannot be determined prior to start of the work:
 - 1. Engineer or Owner will issue a construction change authorization directing Contractor to proceed with the change on this basis of unit prices and will cite the applicable unit prices.
 - 2. At completion of the change, the Engineer will determine the cost of such work based on the unit prices and quantities used. Contractor shall submit documentation to establish the number of units of each item and any claims for a change in Contract Time.
 - 3. Engineer will sign and date the Change Order to indicate their agreement with the terms therein.

4. Owner and Contractor will sign and date the Change Order to indicate their agreement with the terms therein.

1.8 CORRELATION WITH CONTRACTOR'S SUBMITTALS

- A. Periodically revise Request for Payment forms to record each change as a separate item of Work, and to record the adjusted Contract Sum.
- B. Periodically revise the construction Schedule to reflect each change in Contract Time.
- C. Upon completion of work under a Change Order, enter pertinent changes in Record Documents.

PART 2 - PRODUCTS

N/A

PART 3 - EXECUTION

N/A

END OF SECTION 01 26 63

SECTION 01 29 00 – PAYMENT PROCEDURES

PART 1 - GENERAL

1.1 REQUIREMENTS INCLUDED

- A. Submit Applications for Payment to Engineer in accordance with the schedule established by Conditions of the Contract and Agreement between Owner and Contractor.

1.2 RELATED REQUIREMENTS

- A. Agreement between Owner and Contractor: Lump Sum and/or Unit Prices.
- B. Conditions of the Contract: Progress Payments, Retainages and Final Payment.
- C. Section 01 77 00: Closeout Procedures.

1.3 FORMAT AND DATA REQUIRED

- A. Submit applications typed on EJDC Document C-620 (or other approved format), Application for Payment, with itemized data typed on 8-1/2" x 11" white paper continuation sheets.
- B. Provide itemized data on continuation sheet. Format, schedules, line items and values: Those of the Schedule of Values accepted by Engineer.
- C. Provide copies of all required Erosion Control Inspection Reports for the pay period.
- D. Provide copies of all weight tickets, measurements, surveys, etc. for unit price items.

1.4 PREPARATION OF APPLICATION FOR EACH PROGRESS PAYMENT

- A. Application Form:
 - 1. Fill in required information, including that for Change Order executed prior to date of submittal of application.
 - 2. Fill in summary of dollar values to agree with respective totals indicated on continuation sheets.
 - 3. Execute certification with signature of a responsible officer of Contractor's firm.
- B. Continuation Sheets:
 - 1. Fill in total list of all scheduled component items of Work, with item number and scheduled dollar value for each item.

2. Fill in dollar value in each column for each scheduled line item when work has been performed or products stored.
3. Round off values to nearest dollar or as specified for Schedule of Values.
4. List each Change Order executed prior to date of submission, at the end of the continuation sheets.
5. List by Change Order Number, and description, as for an original component item of work.

1.5 SUBSTANTIATING DATA FOR PROGRESS PAYMENTS

- A. When the Owner or the Engineer requires substantiating data, Contractor shall submit suitable information, with a cover letter identifying:
 - B. Project
 - C. Application number and date
 - D. Detailed list of enclosures
 - E. For stored products:
 1. Item number and identification as shown on application.
 2. Description of specific material.
- F. Submit one copy of data and cover letter for each copy of application.

1.6 PREPARATION OF APPLICATION FOR FINAL PAYMENT

- A. Fill in Application form as specified for progress payments.
- B. Use continuation sheet for presenting the final statement of accounting as specified in Section 01 77 00 – Closeout Procedures.

1.7 SUBMITTAL PROCEDURE

- A. Submit Applications for Payment to Engineer at the times stipulated in the Agreement.
- B. Submit one pdf copy of application to EOR via email.
- C. When Engineer finds Application properly completed and correct, he will transmit certificate for payment to Owner, with copy to Contractor.

END OF SECTION 01 29 00

SECTION 01 32 16 – CONSTRUCTION SCHEDULES

PART 1 - GENERAL

1.1 REQUIREMENTS INCLUDED

- A. Promptly after award of the Contract, prepare and submit to Engineer estimated construction progress schedules for the Work, with sub-schedules of related activities which are essential to its progress.
- B. Submit revised progress schedules periodically.

1.2 RELATED REQUIREMENTS

- A. Conditions of the Contract
- B. Section 01 11 00: Summary of Work
- C. Section 01 33 00: Submittal Procedures

1.3 FORM OF SCHEDULES

- A. Prepare schedules in the form of a horizontal bar chart.
 - 1. Provide separate horizontal bars for each trade or operation.
 - 2. Horizontal time scale: Identify the first workday of each week.
 - 3. Scale and spacing: To allow space for notations and future revisions.
 - 4. Minimum sheet size: 8-1/2" x 11".
- B. Format of listings: The chronological order of the start of each item of work.
- C. Identification of listings: By major specification section numbers.

1.4 CONTENT OF SCHEDULES

- A. Construction Progress Schedule:
 - 1. Show the complete sequence of construction by activity.
 - 2. Show the dates for the beginning and completion of each major element of construction. Where applicable, specifically list:
 - a. Clearing
 - b. Excavation
 - c. Various installations
 - d. Subcontractor work
 - e. Equipment installation

f. Landscaping

3. Show projected percentage of completion for each item, as of the first day of each month.

B. Submittals Schedule for Shop Drawings, Product data and samples. Show:

1. The dates for Contractor's submittals.
2. The dates approved submittals will be required for the Engineer.

C. Prepare and submit sub-schedules for each separate stage of work specified in Section 01010.

D. Provide sub-schedules to define critical portions of prime schedules.

1.5 PROGRESS REVISIONS

A. Indicate progress of each activity to date of submissions.

B. Show changes occurring since previous submission of schedule:

1. Major changes in scope.
2. Activities modified since previous submission.
3. Revised projections of progress and completion.
4. Other identifiable changes.

C. Provide a narrative report as needed to define:

1. Problem areas, anticipated delays, and the impact on the schedule.
2. Corrective action recommended, and its effect.
3. The effect of changes on schedules of other prime contractors.

1.6 SUBMISSIONS

A. Submit initial schedules within fifteen (15) days after award of Contract.

1. Engineer will review schedules and return review copy within ten (10) days after receipt.
2. If required, resubmit within seven (7) days after return of review copy.

B. Submit revised progress schedules with each application for payment.

C. Submit the number of opaque reproductions which the Contractor requires, plus two copies which will be retained by the Engineer.

1.7 DISTRIBUTION

A. Distribute copies of the reviewed schedules to:

1. Job site files.
2. Subcontractors.
3. Other concerned parties.

B. Instruct recipients to report promptly to the Contractor, in writing, any problems anticipated by the projections shown in the schedules.

PART 2 - PRODUCTS

N/A

PART 3 - EXECUTION

N/A

END OF SECTION 01 32 16

SECTION 01 33 00 – SUBMITTAL PROCEDURES

PART 1 - GENERAL

1.1 RELATED DOCUMENTS

- A. Drawings and general provisions of Contract, including General and Supplementary Conditions and other Division 1-Specification sections, apply to work of this section.

1.2 DESCRIPTION OF REQUIREMENTS

- A. The types of submittal requirements specified in this section include shop drawings, product data, samples, and miscellaneous work-related submittals. Individual submittal requirements are specified in applicable sections for each unit of work. Refer to other Division_1 sections and other contract documents for requirements of administrative submittals.
- B. Definitions: Work related submittals of this section are categorized for convenience as follows:
 - 1. Shop drawings include specially prepared technical data for this project, including drawings, diagrams, performance curves, data sheets, schedules, templates, patterns, reports, calculations, instructions, measurements and similar information not in standard printed form for general application to a range of similar projects.
 - 2. Product data include standard printed information on materials, products and systems; not specially prepared for this project, other than the designation of selections from among available choices printed therein.
 - 3. Samples include both fabricated and un-fabricated physical examples of materials, products and units of work; both as complete units and as smaller portions of units of work; either for limited visual inspection or (where indicated) for more detailed testing and analysis.
 - 4. Miscellaneous submittals related directly to the work (non-administrative) include warranties, maintenance agreements, workmanship bonds, project photographs, survey data and reports, physical work records, quality testing and certifying reports, copies of industry standards, record drawings, field measurement data, operating and maintenance materials, overrun stock, and similar information, devices and materials applicable to the work and not processed as shop drawings, product data or samples.

1.3 GENERAL SUBMITTAL REQUIREMENTS

- A. Coordination and Sequencing: Coordinate preparation and processing of submittals with performance of the work so that work will not be delayed by submittals. Coordinate and sequence different categories of submittals for same work, and for interfacing units of work, so that one will not be delayed for coordination of A/E's review with another.

- B. Preparation of Submittals: Provide permanent marking on each submittal to identify project, date, Contractor, subcontractor, submittal name and similar information to distinguish it from other submittals. Show Contractor's executed review and approval marking and provide space for Architect's/Engineer's "Action" marking. Package each submittal appropriately for transmittal and handling. Submittals which are received from sources other than through Contractor's office will be returned by A/E "without action".

1.4 SPECIFIC-CATEGORY SUBMITTAL REQUIREMENTS

- A. General: Except as otherwise indicated in individual work sections, comply with requirements specified herein for each indicated category of submittal.
- B. Shop Drawings: Provide newly prepared information, on reproducible sheets, with graphic information at accurate scale (except as otherwise indicated), with name of preparer indicated (firm name). Show dimensions and note which are based on field measurement. Identify materials and products in the work shown. Indicate compliance with standards, and special coordination requirements. Do not allow shop drawing copies without appropriate final "Action" markings by Architect/Engineer to be used in connection with the work.
 - 1. Initial Submittal: Submit 1 Digital Copy
 - 2. Final Submittal: Submit 1 Digital Copy
 - 3. Product Data: Collect required data into one submittal for each unit of work or system; and mark each copy to show which choices and options are applicable to project. Include manufacturer's standard printed recommendations for application and use, compliance with standards, application of labels and seals, notation of field measurements which have been checked, and special coordination requirements. Maintain one set of product data (for each submittal) at project site, available for reference by Architect/Engineer and others.
 - 4. Submittals: Do not submit product data, or allow its use on the project, until compliance with requirements of contract documents has been confirmed by Contractor. Submittal is for information and record, unless otherwise indicated. Initial submittal is final submittal unless returned promptly by Architect/Engineer, marked with an "Action" which indicates an observed non-compliance.
 - 5. Samples: Provide units identical with final condition of proposed materials or products for the work. Include "range" samples (not less than 3 units) where unavoidable variations must be expected and describe or identify variations between units of each set. Provide full set of optional samples where Architect's/Engineer's selection is required. Prepare samples to match Architect's/Engineer's samples where so indicated. Include information with each sample to show generic description, source or product name and manufacturer, limitations, and compliance with standards. Samples are submitted for review and confirmation of color, pattern, texture, and "kind" by Architect/Engineer. Architect/ Engineer will not "test" samples (except as otherwise indicated) for compliance with other requirements, which are therefore the exclusive responsibility of Contractor.
 - 6. Submittals: At Contractor's option, provide preliminary submittal of a single set of samples for Architect's/Engineer's review and "action." Otherwise, initial submittal is

final submittal unless returned with "action" which requires re-submittal. Submit 1 set of samples in final submittal.

7. Quality Control Set: Maintain returned final set of samples at project site, in suitable condition and available for quality control comparisons by Architect/Engineer, and by others.

1.5 INSPECTION AND TEST REPORTS

- A. Classify each as either "shop drawing" or "product data", depending upon whether report is uniquely prepared for project or a standard publication of workmanship control testing at point of production; process accordingly.

1.6 WARRANTIES

- A. Refer to "Products" section for specific general requirements on warranties, product/workmanship bonds, and maintenance agreements. In addition to copies desired for Contractor's use, furnish 2 executed copies, except furnish 2 additional (conformed) copies where required for maintenance manuals.

1.7 CLOSEOUT SUBMITTALS

- A. Refer to individual work sections and to "closeout" sections for specific requirements on submittal of closeout information, materials, tools and similar items.
 1. Record Document Copies: Furnish one set.
 2. Maintenance/Operating Manuals: Furnish 2 bound copies.
 3. Materials and Tools: Refer to individual work sections for required quantities of spare parts, extra and overrun stock, maintenance tools and devices, keys, and similar physical units to be submitted.
 4. General Distribution: Provide additional distribution of submittals (not included in foregoing copy submittal requirements) to subcontractors, suppliers, fabricators, installers, governing authorities, and others as necessary for proper performance of the work. Include such additional copies in transmittal to Architect/Engineer where required to receive "Action" marking before final distribution. Record distributions on transmittal forms.

1.8 ACTION ON SUBMITTALS

- A. Architect's/Engineer's Action: Where action and return is required or requested, Architect/Engineer will review each submittal, mark with "Action", and where possible return within 2 weeks of receipt. Where submittal must be held for coordination, Contractor will be so advised by A/E without delay.
- B. Action Stamp: Architect's/Engineer's action stamp, for use on submittals to be returned to Contractor, is self-explanatory as marked.

PART 2 - PRODUCTS

A. N/A

PART 3 - EXECUTION

A. N/A

END OF SECTION 01 33 00

SECTION 01 42 00 – REFERENCE STANDARDS

PART 1 - GENERAL

The General Conditions of the Contract and Supplementary General Conditions of the Contract of this specification are herein made a part of this section of the specifications. The Contractor and subcontractor shall carefully examine all drawings and all sections of the specifications so as to properly coordinate his work with the work of others.

1.1 REQUIREMENTS INCLUDED

Abbreviations and acronyms used in Contract Documents to identify reference standards.

1.2 QUALITY ASSURANCE

- A. Application: When a standard is specified by reference, comply with requirements and recommendations stated in that standard, except when requirements are modified by the Contract Documents or applicable codes establish stricter standards.
- B. Publication Date: The publication in effect on the date of issue of Contract Documents, except when a specific publication date is specified.

1.3 ABBREVIATIONS, NAMES, AND ADDRESSES OF ORGANIZATIONS

| | |
|---|--|
| (AASHTO) American Association of State Highway and Transportation Officials 444 North Capitol Street, N.W. Washington, D.C. 20001 | (ANSI) American National Standards Institute (Formerly American Standards Association – ASA) 1430 Broadway New York, NY 10018 |
| (AREA) American Railroad Engineering Association 2000 "L" Street, N.W. Washington, D.C. 20036 | (ASCE) American Society of Civil Engineers 345 East 47th Street New York, NY 10017 |
| (ASME) American Society of Mechanical Engineers 345 East 47th Street New York, New York 10017 | (ASTM) American Society of Testing and Materials 1916 Race Street Philadelphia, PA 19103 |
| (AWWA) American Water Works Association 6666 W. Quincy Avenue Denver, Colorado 80235 | (FHWA) Federal Highway Administration Federal Building. U.S. Courthouse Nashville, TN 37202 |

(FSS)
Federal Specification and Standards
General Services Administration
Specifications and Consumer Information
Distribution Section (WFSIS)
Washington Navy Yard, Building 197
Washington, D.C. 20407

(NACE)
National Association of Coatings Engineers

(TDEC-RES)
Tennessee Department of Environment
and Conservation
10th Floor, L&C Tower
401 Church Street
Nashville, Tennessee 37243

(NIOSH)
National Institute for Occupational Health
and Safety

(TDOT)
Tennessee Department of Transportation
James K. Polk Building
505 Deaderick Street
Nashville, Tennessee 37219

(SSPC)
Steel Structures Painting Council

PART 2 - PRODUCTS

N/A

PART 3 - EXECUTION

N/A

END OF SECTION 01 42 00

SECTION 01 74 00 - CLEANING

PART 1 - GENERAL

The General Conditions of the Contract and Supplementary General Conditions of the contract of this specification are herein made a part of this section of the specifications. The Contractor and subcontractor shall carefully examine all drawings and all sections of the specifications so as to properly coordinate his work with the work of others.

1.1 REQUIREMENTS INCLUDED

- A. Execute cleaning, during progress of the work, and at completion of the work, as required by General Conditions.

1.2 RELATED REQUIREMENTS

- A. Conditions of the Contract
- B. Each Specification Section - Cleaning for Specific products or work.

1.3 DISPOSAL REQUIREMENTS

- A. Conduct cleaning and disposal operations to comply with codes, ordinances, regulations, and anti-pollution laws.

PART 2 - PRODUCTS

2.1 MATERIALS

- A. Use only those cleaning materials which will not create hazards to health or property, and which will not damage surfaces.
- B. Use only those cleaning materials and methods recommended by manufacturer of the surface material to be cleaned.
- C. Use cleaning materials only on surfaces recommended by cleaning by manufacturer.

PART 3 - EXECUTION

3.1 DURING CONSTRUCTION

- A. Execute periodic cleaning to keep the work, the site adjacent properties free from accumulations of water materials, rubbish and windblown debris resulting from construction operations. Streets shall be periodically swept using a power brush sweeper.
- B. Provide on-site containers for the collection of waste materials, debris, and rubbish.
- C. Remove waste materials, debris, and rubbish from the site periodically and dispose of at legal disposal area away from the site.

3.2 DUST CONTROL

- A. Clean interior spaces prior to the start of finish painting and continue cleaning on an as-needed basis until painting is finished.
- B. Schedule operations so that dust and other contaminants resulting from the cleaning process will not fall on wet or newly coated surfaces.

3.3 FINAL CLEANING

- A. Employ skilled workmen for final cleaning.
- B. Remove grease, mastic, adhesives, dust, dirt, stains, labels, fingerprints, and other foreign materials, from sight-exposed interior and exterior surfaces.
- C. Broom clean exterior paved surfaces; rake clean other surfaces of the grounds.
- D. Prior to final completion, or Owner occupancy, Contractor shall conduct an inspection of sight-exposed interior and exterior surfaces and all work areas to verify that the entire work is clean.

END OF SECTION 01 74 00

SECTION 01 77 00 – CLOSEOUT PROCEDURES

PART 1 - GENERAL

1.1 RELATED DOCUMENTS

- A. Drawings and general provisions of Contract, including General and Supplementary Conditions and other Division 0 Specification sections, apply to work of this section.

1.2 DESCRIPTION OF REQUIREMENTS

- A. Closeout is hereby defined to include general requirements near end of Contract Time, in preparation for final acceptance, final payment, normal termination of contract, occupancy by Owner and similar actions evidencing completion of the work. Specific requirements for individual units of work are specified in sections of Division 2 through 16. Time of closeout is directly related to "Substantial Completion", and therefore may be either a single time period for entire work or a series of time periods for individual parts of the work which have been certified as substantially complete at different dates. That time variation (if any) shall be applicable to other provisions of this section.

1.3 PREREQUISITES TO SUBSTANTIAL COMPLETION

- A. Prior to requesting Architect's/Engineer's inspection for certification of substantial completion (for either entire work or portions thereof), complete the following and list known exceptions in request:
 - 1. In progress payment request, coincident with or first following date claimed, show either 100% completion for portion of work claimed as "substantially complete", or list incomplete items, value of incompleteness, and reasons for being incomplete.
 - 2. Include supporting documentation for completion as indicated in these contract documents.
 - 3. Submit statement showing accounting of changes to Contract Sum.
 - 4. Advise Owner of pending insurance changeover requirements.
 - 5. Submit specific warranties, workmanship/maintenance bonds, maintenance agreements, final certifications, and similar documents.
 - 6. Obtain and submit releases enabling Owner's full and unrestricted use of the work and access to services and utilities, including (where required) occupancy permits, operating certificates, and similar releases.
 - 7. Submit record drawings, maintenance manuals, final project photographs, damage or settlement survey, property survey, and similar final record information.
 - 8. Deliver tools, spare parts, extra stocks of materials, and similar physical items to Owner.
 - 9. Make final changeover of locks and transmit keys to Owner and advise Owner's personnel of changeover in security provisions.

10. Complete startup testing of systems, and instructions of Owner's operating/maintenance personnel. Discontinue (or change over) and remove from project site temporary facilities and services, along with construction tools and facilities, mockups, and similar elements.
11. Complete final cleaning up requirements, including touchup painting of marred surfaces.
12. Touchup and otherwise repair and restore marred exposed finishes.

1.4 INSPECTION PROCEDURES

- A. Upon receipt of Contractor's request, Architect/Engineer will either proceed with inspection or advise Contractor of prerequisites not fulfilled. Following initial inspection, Architect/Engineer will either prepare certificate of substantial completion or advise Contractor of work which must be performed prior to issuance of certificate; and repeat inspection when requested and assured that work has been substantially completed. Results of completed inspection will form initial "punch list" for final acceptance.

1.5 PREREQUISITES TO FINAL ACCEPTANCE

- A. Prior to requesting Architect's/Engineer's final inspection for certification of final acceptance and final payment, as required by General Conditions, complete the following and list known exceptions (if any) in request:
 1. Submit final payment request with final releases and supporting documentation not previously submitted and accepted. Include certificates of insurance for products and completed operations where required.
 2. Submit updated final statement, accounting for additional (final) changes to Contract Sum.
 3. Submit certified copy of Architect's/Engineer's final punch list of itemized work to be completed or corrected, stating that each item has been completed or otherwise resolved for acceptance, endorsed and dated by Architect/Engineer.
 4. Submit final meter readings for utilities, measured record of stored fuel, and similar data as of time of substantial completion or when Owner took possession of and responsibility for corresponding elements of the work.
 5. Submit consent of surety.
 6. Submit final liquidated damages settlement statement, acceptable to Owner.
 7. Revise and submit evidence of final, continuing insurance coverage complying with insurance requirements.
 8. Submit copy of Notice of Termination acceptance letter from the Tennessee Department of Environment and Conservation.

1.6 REINSPECTION PROCEDURE

- A. Upon receipt of Contractor's notice that the work has been completed, including punch list items resulting from earlier inspections, and accepting incomplete items delayed because of acceptable circumstances, Architect/Engineer will reinspect the work. Upon completion of reinspection, Architect/Engineer will either prepare certificate of final acceptance or advise Contractor of work not completed or obligations not fulfilled as required for final acceptance. If necessary, procedure will be repeated.

1.7 RECORD DOCUMENT SUBMITTALS

- A. Specific requirements for record documents are indicated in individual sections of these specifications. Other requirements are indicated in General Conditions. General submittal requirements are indicated in "Submittals" sections. Do not use record documents for construction purposes; protect from deterioration and loss in a secure, fire resistive location; provide access to record documents for Architect's/Engineer's reference during normal working hours.
- B. Record Drawings
 - 1. Maintain a whiteprint set (blue line or black line) of contract drawings and shop drawings in clean, undamaged condition, with markup of actual installations which vary substantially from the work as originally shown. Mark whichever drawing is most capable of showing "field" condition fully and accurately; however, where shop drawings are used for markup, record a cross-reference at corresponding location on working drawings. Mark with red erasable pencil and, where feasible, use other colors to distinguish between variations in separate categories of work. Markup new information, which is recognized to be of importance to Owner, but was for some reason not shown on either contract drawings or shop drawings. Give particular attention to concealed work, which would be difficult to measure and record at a later date. Note related change order numbers where applicable. Organize record drawing sheets into manageable sets, bind with durable paper cover sheets, and print suitable titles, dates and other identification on cover of each set.
- C. Record Specifications
 - 1. Maintain one copy of specifications, including addenda, change orders and similar modifications issued in printed form during construction, and markup variations (of substance) in actual work in comparison with text of specifications and modifications as issued. Give particular attention to substitutions, selection of options, and similar information on work where it is concealed or cannot otherwise be readily discerned at a later date by direct observation. Note related record drawing information and product data, where applicable. Upon completion of markup, submit to Architect/Engineer for Owner's records.
- D. Record Sample Submittal

1. Immediately prior to date(s) of substantial completion, Architect/Engineer (and including Owner's personnel where desired) will meet with Contractor at site and will determine which (if any) of submitted samples maintained by Contractor during progress of the work are to be transmitted to Owner for record purposes. Comply with Architect's/Engineer's instructions for packaging, identification marking, and delivery to Owner's sample storage space.

E. Miscellaneous Record Submittals

1. Refer to other sections of these specifications for requirements of miscellaneous record keeping and submittals in connection with actual performance of the work. Immediately prior to date(s) of substantial completion, complete miscellaneous records, and place in good order, properly identified and bound or filed, ready for continued use and reference. Submit to Architect/Engineer for Owner's records.

F. Maintenance Manuals

1. Organize maintenance and operating manual information into suitable sets of manageable size and bind into individual binders properly identified and indexed (thumb tabbed). Include emergency instructions, spare parts listing, copies of warranties, wiring diagrams, recommended "turnaround" cycles, inspection procedures, shop drawings, product data, and similar applicable information. Bind each manual of each set in a heavy-duty 2", 3-ring vinyl covered binder, and include pocket folders for folded sheet information. Mark identification on both front and spine of each binder.

PART 2 - PRODUCTS

N/A

PART 3 - EXECUTION

3.1 CLOSEOUT PROCEDURES

- A. General Operating/Maintenance Instructions
- B. Arrange for each installer of work requiring continuing maintenance or operation, to meet with Owner's personnel, at project site, to provide basic instructions needed for proper operation and maintenance of entire work. Include instructions by manufacturer's representatives where installers are not expert in the required procedures. Review maintenance manuals, record documentation, tools, spare parts and materials, lubricants, fuels, identification system, control sequences, hazards, cleaning and similar procedures and facilities. For operational equipment, demonstrate startup, shutdown, emergency operations, noise and vibration adjustments, safety, economy/efficiency adjustments, energy effectiveness, and similar operations. Review maintenance and operations in relation with applicable warranties, agreements to maintain, bonds, and similar continuing commitments.

3.2 FINAL CLEANING

- A. Special cleaning for specific units of work is specified in sections of Divisions 2 through 16. General cleaning during progress of work is specified in General Conditions and as temporary services in "Temporary Facilities" section of this Division. Provide final cleaning of the work, at time indicated, consisting of cleaning each surface or unit of work to normal "clean" condition expected for a first-class building cleaning and maintenance program. Comply with manufacturer's instructions for cleaning operations. The following are examples, but not by way of limitation, of cleaning levels required:
1. Remove labels which are not required as permanent labels.
 2. Clean transparent materials, including mirrors and window/door glass, to a polished condition, removing substances which are noticeable as vision obscuring materials. Replace broken glass and damaged transparent materials.
 3. Clean exposed exterior and interior hard surfaced finishes, to a dirt-free condition, free of dust, stains, films, and similar noticeable distracting substances. Except as otherwise indicated, avoid disturbance of natural weathering of exterior surfaces. Restore reflective surfaces to original reflective condition.
 4. Wipe surfaces of mechanical and electrical equipment clean; remove excess lubrication and other substances.
 5. Remove debris and surface dust from limited access spaces including roofs, plenums, shafts, trenches, equipment vaults, manholes, attics, and similar spaces.
 6. Clean concrete floors in non-occupied spaces broom clean.
 7. Vacuum clean carpeted surfaces and similar soft surfaces.
 8. Clean plumbing fixtures to a sanitary condition, free of stains including those resulting from water exposure.
 9. Clean food service equipment to a condition of sanitation ready and acceptable for intended food service use.
 10. Clean light fixtures and lamps so as to function with full efficiency.
 11. Clean project site (yard and grounds), including landscape development areas, of litter and foreign substances. Sweep paved areas to a broom clean condition; remove stains, petrochemical spills, and other foreign deposits. Rake grounds which are neither planted nor paved, to a smooth, even textured surface.

3.3 REMOVAL OF PROTECTION

- A. Except as otherwise indicated or requested by Architect/Engineer, remove temporary protection devices and facilities which were installed during course of the work to protect previously completed work during remainder of construction period.

3.4 COMPLIANCES

- A. Comply with safety standards and governing regulations for cleaning operations. Do not burn waste materials at site, or bury debris or excess materials on Owner's property, or discharge volatile or other harmful or dangerous materials into drainage systems; remove waste materials from site and dispose of in a lawful manner.

- B. Where extra materials of value remaining after completion of associated work have become Owner's property, dispose of these to Owner's best advantage as directed.

END OF SECTION 01 77 00

DIVISION 31

EARTHWORK

SECTION 31 10 00 – SITE CLEARING

PART 1 - GENERAL

1.1 WORK INCLUDED

- A. Clearing, grubbing, removal and disposal of vegetation, rocks, roots, and debris within the limits of the work except objects designated on the drawings to remain.
- B. Preserve from injury or defacement, all vegetation, and objects to remain.

1.2 RELATED WORK

- A. Section 31 20 00: Earthwork.
- B. Section 31 23 00: Trenching, Backfilling, and Compaction.
- C. Section 31 25 00: Erosion Control.

1.3 LIMITS OF WORK

- A. Rights-of-way as necessary to the limits shown on the Plans.
- B. Construction area.
- C. Borrow pit areas.
- D. Designated stockpiles of construction material other than borrow material.

1.4 PROTECTION

- A. Protect living trees not marked for removal and outside the construction area. Treat cut or scarred surfaces of trees or shrubs with a paint prepared especially for tree surgery.
- B. Protect benchmarks and existing structures, roads, sidewalks, paving and curbs against damage from vehicular or foot traffic.
- C. Maintain designated temporary roadways, walkways, and detours, for vehicular and pedestrian traffic.

PART 2 - PRODUCTS

N/A

PART 3 - EXECUTION

3.1 PREPARATION

- A. Maintain benchmarks, monuments, and other reference points. Reestablish if disturbed or destroyed at no cost to Owner.

3.2 CLEARING AND GRUBBING

- A. Clear right-of-way; borrow pit and other stockpile areas of objectionable material to the ground surface except for trees and stumps.
- B. Cut trees and stumps to within six inches of the ground surface or below water level in swampy areas where embankments are to be constructed provided undercutting or other corrective measures are not stipulated.
- C. Cut trees and stumps outside the construction area marked for removal by the Engineer to within six inches of the ground surface.
- D. Remove low hanging, unsound or unsightly branches on trees or shrubs designated to remain.
- E. Trim branches of trees extending over the roadbed to a clear height of twenty feet above the roadbed surface.
- F. Grub construction area of protruding obstructions except sound undisturbed stumps and roots six inches or less above the ground which will be a minimum of 5 feet below subgrade or embankment slope provided undercutting; topsoil stripping or other corrective measures are not stipulated.
- G. Grub borrow pit and stockpile areas of all objectionable material. Strip overburden over the material to be obtained in stockpile area.
- H. Perform clearing and grubbing well in advance of construction or material removal activities.

3.3 BACKFILLING AND SURFACE PREPARATION

- A. Backfill and compact all depressions resulting from clearing and grubbing with suitable materials.
 - 1. Backfill embankment areas to natural ground elevation.
 - 2. Backfill excavation areas below finished subgrade to finished subgrade.
- B. Perform backfilling a satisfactory distance ahead of construction operations.
- C. Prepare areas designated on the drawings to receive erosion control matting to smooth surfaces that have been shaped, fertilized, and seeded.

3.4 DEBRIS REMOVAL

- A. Promptly remove cleared debris from site.
- B. Obtain permission from applicable regulatory authority for disposal of debris to waste disposal site.

3.5 MEASUREMENT AND PAYMENT

- A. Measurement of clearing and grubbing area will not be made.
- B. No specific payment for clearing and grubbing will be made. Include cost in other items.

END OF SECTION 31 10 00

SECTION 31 23 01 – TRENCHING, BACKFILLING, AND COMPACTION

PART 1 - GENERAL

1.1 WORK INCLUDED

- A. Excavation for piped utility material.
- B. Provide necessary sheeting, shoring, and bracing.
- C. Prepare trench bottom with appropriate materials.
- D. Dewater excavation as required.
- E. Place and compact granular beds, as required.
- F. Backfilling.

1.2 RELATED WORK

- A. Section 31 00 00: Earthwork
- B. Section 32 92 00: Turfs and Grasses
- C. Section 32 92 23: Sodding
- D. Section 33 41 00: Storm Utility Drainage Piping

1.3 PRECAUTIONS

- A. Notify utility companies when necessary to disturb existing facilities and abide by their requirements for repairing and replacing.
- B. Protect all vegetation and other features to remain.
- C. Protect all benchmarks and survey points.
- D. Repair of existing pavement shall be in accordance with the regulations of the controlling authority.

PART 2 - PRODUCTS

2.1 BEDDING AND BACKFILL MATERIALS -GRAVITY SEWERS

- A. Class I Material: Angular, 1/4 to 1-inch graded stone including a number of fill materials that have regional significance such as crushed stone, cinders, slag, and crushed shells.
- B. Class II Material: Coarse sands and gravels with a maximum particle dimension of 1 1/2-inch including variously graded sands and gravels containing small percentages of fines, generally granular and non-cohesive, either wet or dry.
- C. Class III Material: Fine sand and clayey gravels, including fine sands, sand-clay mixtures, and gravel-clay mixtures.
- D. Class IV Material: Silt, silty clays, and clay, including inorganic clays and silts of medium to high plasticity and liquid limits.
- E. Class V Materials: Organic soils, as well as soil containing frozen earth, debris, rocks larger than 1 1/2-inches and other foreign material.

2.2 BEDDING AND BACKFILL MATERIALS -STORM SEWERS, WATERLINES AND GASLINES

- A. Class A Material: Continuous concrete cradle constructed in conformity with details shown on plans and consisting of miscellaneous exterior concrete as specified in Section 03 00 00.
- B. Class B Material: Sand or a natural sandy soil, all passing a 1/2" sieve with not more than 10% passing a No. 200 sieve; or stone, gravel, chert and slag of Gradation C or D of TDOT specifications.
- C. Class C Material: Natural ground or compacted embankment at a depth of at least 110% of the outside vertical pipe diameter. Class C material shall be clean, free from organic material, and stable under compaction.
- D. In rock cuts or other areas where free drainage bedding or backfill materials are required, use crushed stone, slag, or washed gravel of size 6, 7, 8, 57 or 78 of TDOT specifications.
- E. Do not use any rock, stone, gravel, chert, or slag within one foot of the waterlines.

PART 3 - EXECUTION

3.1 PREPARATION

- A. Install barriers and other devices to protect areas adjacent to construction.
- B. Protect and maintain all benchmarks and other survey points.

3.2 EXCAVATION TRENCHES

- A. Perform in such a manner as to form a suitable trench in which to place the pipe and so as to cause the least inconvenience to the public.
- B. Maximum width at the crown of the pipe - 2 feet plus the nominal diameter of the pipe.
- C. Cut pavement along neat, straight lines with either a pavement breaker or pavement saw.
- D. Trench depth: for water lines - sufficient to provide minimum cover of 36-inches over the top of the pipe unless shown otherwise on the Plans; for sewer lines - as shown on the Plans or as specified; for gas lines - sufficient to provide minimum cover of 36-inches over the top of the pipe unless shown otherwise in the Plans.
- E. Align trench as shown on the Plans unless a change is necessary to miss on unforeseen obstruction.
- F. For water and gas pipe, shape the bottom of the trench to provide uniform bearing of the pipe on undisturbed earth throughout its entire length. Dig bell holes in sufficient depth to secure uniform support of the pipe for its full length.
- G. For sewer pipe, fill the bottom of the trench with granular material as specified herein.
- H. When unstable soil is encountered at the trench bottom, remove it to a depth directed by the Engineer to assure support of the pipeline and backfill to the proper grade with coarse aggregate AASHTO M-43, Size No. 2, 3, or 4 as directed.
- I. Remove rock encountered in trench excavation to a depth of 6-inches below the bottom of the pipe barrel, backfill with an approved material, and compact to uniformly support to pipe. In no case shall solid rock exist within 6-inches of the finished pipeline.
- J. When rock borings or soundings are provided, they are for information only and do not guarantee existing conditions. Make such investigations as deemed necessary to determine existing conditions.
- K. At any draw, creek, gully crossing or other place where rough terrain prevails requiring a sag-bend or deflection of the water or gas line greater than 2-1/2 degrees the trench shall be graded to avoid the use of bends or deflections more than 2-1/2 degrees unless otherwise authorized by the Engineer. The minimum allowable cover for overbends shall be 36-inches.
- L. In all cases where materials are deposited along open trenches, they shall be placed so that in the event of rain, no damage will result to the work or adjacent property.

3.3 SHEETING, SHORING, AND BRACING

- A. When necessary or when directed by the Engineer, furnish, put in place, and maintain such sheeting, bracing, etc., as may be required to support to sides of the excavation and to prevent movement.

- B. Take care to prevent voids outside the sheeting.
- C. If voids are formed, immediately fill and ram to the satisfaction of the Engineer.
- D. Devise plans for performing this work subject to the approval of the Engineer.
- E. Unless adjacent facilities will be injured, remove all sheeting, shoring, and bracing after backfilling has been placed to depth of 18-inches over the pipeline.
- F. Cut shoring off at the top of the pipe and leave the lower section in the trench.

3.4 USE OF EXPLOSIVES

- A. Conduct all blasting operations in accordance with prevailing municipal, state or other agency regulations, codes, ordinances, or laws.
- B. Exercise due caution when blasting adjacent to existing structures and pipelines.
- C. If structures or pipelines are damaged, promptly replace or repair them at no expense to Owner.
- D. Do not conduct blasting operations within 25-feet of water, sewer, gas or other utility lines, unless otherwise directed by the Engineer.
- E. Cover all shots with blasting mats to prevent flying material.

3.5 DISPOSAL OF EXCAVATING MATERIAL

- A. Satisfactorily dispose of all excess excavated material that cannot be used for backfilling.

3.6 UNAUTHORIZED EXCAVATION

- A. All excavation outside or below the proposed lines and grades shown on the Plans or directed by the Engineer.
- B. Backfill areas of unauthorized excavation with the type material necessary (earth, rock or concrete) to insure the stability of the structure of construction involved as approved by the Engineer.
- C. Unauthorized excavation or backfill to replace same shall not be a pay item.

3.7 UNDERWATER EXCAVATION

- A. Where the excavation shown on the plans is under water or is taking on water, the Contractor may adopt and carry out any method he deems feasible for the performance of the excavation work and for the protection of the work thereafter; provided the method and equipment used results in completed work which complies with the specifications and is acceptable to the Engineer. The excavation area shall be protected from damage during the excavation period until all contemplated construction work therein has been completed. The cost of all temporary construction necessary or incidental thereto, including the cost of installing and removing sandbags, coffer dams, sheet piling, excavation, backfill, pumping and dewatering, shall be considered an integral part of the excavation and no separate payment shall be made.

3.8 REMOVAL OF WATER

- A. Keep excavated areas free of water while work is in progress.
- B. Well-pointing shall be performed if required.
- C. Take precautions to prevent the displacement of structures of pipelines as a result of accumulated water.

3.9 OBSTRUCTIONS

- A. Obstructions shown on the Plans are for information only and do not guarantee their exact locations nor that other obstructions are not present.
- B. When utilities or obstructions are not shown on the plans but are present off the roadway at the location of the proposed pipeline route, the Contractor may request to relocate the pipeline in the roadway if necessary to avoid disturbing the utility or obstructions.
- C. If the relocation is approved, the Contractor shall receive compensation for additional granular backfill and pavement replacement as measured and paid for under the appropriate line items.
- D. Exercise due care in excavating adjacent to existing obstructions and do not disturb same unless necessary.
- E. In the event obstructions are disturbed, repair or replace as quickly as possible to the condition existing prior to their disturbance. This repair or replacement will not be a pay item, unless the Engineer and Owner agree the damaged line was not properly located and agree it was not possible for the Contractor to avoid damage
- F. If desired by the utility company, pay for the repair or replacement work performed by the forces of the utility company or other appropriate party.

- G. If replacement or repair of disturbed obstructions is not performed after a reasonable period, the Owner may have the necessary work completed and deduct the cost of same from payments to the Contractor.

3.10 STORM SEWER BEDDING

- A. Use Class B bedding unless otherwise shown on the plans.
- B. Install bedding in a trench cut in natural ground or compacted embankment.
- C. Bed pipe on 6-inches of Class B material and sufficient additional Class B material accurately shaped by a template to fit the lower part of the pipe exterior.
- D. Ram and tamp in layers not over 6-inches, in loose thickness, around the pipe to a minimum depth of that shown on the Plans.
- E. When bell and spigot pipe is to be placed, dig recesses in the bedding material of sufficient width and depth to accommodate the bell.

3.11 GRAVITY SANITARY SEWER BEDDING

- A. Always maintain proper grade and alignment during the bedding and tamping process.
 - 1. Any pipe dislodged during the process shall be replaced by the Contractor at his expense.
 - 2. Dig bell holes to assure uniform support of the pipe.
- B. Bedding for PVC and RCP Sewers:
 - 1. In unimproved areas, completely encapsulate each sewer pipe section with 6-inches of granular material on the top, both sides, and the bottom of the pipe.
 - 2. For PVC sewer pipe, use Class I angular material.
 - 3. Bedding for RCP sewer pipe may be rounded material where crushed material is not readily available.
- C. Bedding for Ductile Iron Pipe Sewers:
 - 1. Lay each sewer pipe section on a 6-inches bed of granular material and backfill to the spring line of the pipe with granular material.
 - 2. In unimproved areas, use Class I or II granular material.
 - 3. In improved areas, use Class I angular material.
- D. Check Dams for Sewer Bedding:
 - 1. An impervious clay ditch check shall be required on the downstream side of all stream and drainage ditch crossings, a length of 15-feet as measured along the center line of the pipe and the full width and depth of the trench excavation.

2. The backfill shall be low permeability clay. The minimum percentage of compaction for the backfill shall be 95% proctor density (ASTM D 1557).
3. This is not a pay item.

3.12 BEDDING FOR WATERLINES AND GASLINES

- A. Bed in a trench cut in natural ground.
- B. Dig bell holes to assure uniform support throughout the entire length of pipe.
- C. Excavate the trench in such a manner as to form a suitable bed on which to place the pipe.
- D. Shape bedding to fit the lower pipe exterior for the specified embedment.

3.13 INITIAL BACKFILLING

- A. Do not begin backfilling before the Engineer has inspected the grade and alignment of the pipe, the bedding of the pipe, and the joints between the pipe.
- B. Install backfilling, together with tamping, until fill has progressed to specified level above the top of the pipe.

1. Sanitary Sewer

- a. Deposit Class I granular material (where required) or loose soil free from lumps, clods, frozen material or stones in layers approximately 6-inches thick.
- b. Compact by hand, or with manually operated machine tampers actuated by compressed air or other suitable means.
- c. Use tamps and machines of a suitable type which do not crush or otherwise damage the pipe.

2. Storm Sewers

- a. Deposit Class B material to the spring line for RCP; to the top of pipe for CMP, HDPE, and HP-STORM; and to 6-inches above the top of pipe for ULTRA-FLO.
- b. Compact initial backfill with manually operated mechanical tampers.

3. Water and Gas Lines

- a. Deposit Class C material to 18" above the top of the pipe.
- b. Compact initial backfill with manually operated mechanical tampers.

- C. Backfilling in improved areas (including under sidewalks) shall be 100% granular material or natural material achieving 95% standard proctor density.

3.14 FINAL BACKFILLING

- A. After initial backfilling, perform final backfilling

B. Backfilling in Unimproved Areas:

1. Dispose of and replace all soft or yielding material which is unsuitable for trench backfill with suitable material.
2. Deposit backfill in 8" lifts to the surface of the ground by dragline, bulldozer, or other suitable equipment in such a manner so as not to disturb the pipe.
3. Compact backfill to a minimum of 85% standard proctor density by rolling, ramming, and/or tamping with tools suitable for the purpose without disturbing pipe.
4. Neatly round sufficient surplus excavated material over the trench to compensate for after settlement.
5. Dispose of all surplus excavated material.
6. Prior to final acceptance, remove all mounds to the elevation of the surrounding terrain and seed or sod per plans.

C. Backfilling beneath Driveways and streets where Non-Rigid and Rigid Type Surfacing is to be Replaced:

1. Use Class I granular material for sewer and Class B material for all other pipes of high weight and density to backfill the entire excavation.
2. Carefully deposit in uniform layers, not to exceed 8-inches thick.
3. Compact each layer thoroughly by rolling, ramming, and tamping with tools suitable for the purpose in such a manner so as to not disturb the pipe.
4. Backfilling in improved areas (including under sidewalks) shall achieve 95% standard proctor density. The top 12-inches shall achieve 100% standard proctor density.

D. Backfilling of Shoulders along Streets and Highways:

1. Backfilling methods and materials for shoulders along streets and highways shall be in accordance with the requirements of governing local, county, or state departments maintaining the roadway or highway.
2. Replace with similar materials, all shoulders which may be damaged or destroyed because of pipe trenching.
3. Where shoulders along state highways have seal coat surfaces, replace with double bituminous seal.
4. Where the State Highway Department or local authority requires trenches to be backfilled entirely with granular material in the shoulder of roads, granular material so placed above the initial backfill, payment shall be included in the lump sum price.

E. Crushed Stone for Pavement Maintenance and Shoulder Replacement:

1. Where possible, salvage and reuse all base material that is removed during construction.
2. Wet and thoroughly compact crushed stone and blade into the existing surface prior to final acceptance.
3. Replace all existing base material displaced during construction.

3.15 MEASUREMENT AND PAYMENT—TRENCHING, BEDDING, AND BACKFILLING

- A. Trenching, backfilling, and compaction shall not be measured or paid by unit price. The cost of this work shall be included in the unit bid price for the various types of pipe called for in the proposal.
- B. All excavated material shall be considered unclassified. No additional payment will be made for the excavation, handling, or disposal of material encountered during trench excavation.

3.16 MEASUREMENT AND PAYMENT—UNDERCUT BEDDING

- A. Should the Engineer direct undercut, undercut bedding shall be paid at the negotiated unit price per ton or cubic yard of material installed including the undercut excavation.

END OF SECTION 31 20 01.01

SECTION 31 25 01 – EROSION CONTROL

PART 1 - GENERAL

1.1 WORK INCLUDED

- A. This work includes the filing of, or a signing onto, of a “Notice of Intent” (NOI), development, execution and implementation of a site-specific “Storm Water Pollution Prevention Plan” (SWPPP) to control erosion and water pollution during construction, maintenance of a log book for the project, regular inspections by certified personnel of the erosion control measures, revisions of the SWPPP, revisions to the erosion control plan as necessary during construction, and filing of a “Notice of Termination” (NOT) when the site is fully stabilized. The contractor shall be advised that erosion control prevention is an ongoing continuous process during construction. Any erosion control plans developed by the designer shall be considered general in nature and may not apply during all phases of construction. In addition, the erosion control plan may have to be modified or additional features added in the field to accomplish the goal of not allowing sediment to leave the site.

1.2 RELATED WORK

- A. Section 01 29 00: Payment Procedures
- B. Section 01 77 00: Closeout Procedures
- C. Section 32 92 00: Turfs and Grasses
- D. Section 32 92 23: Sodding

PART 2 - PRODUCTS

2.1 SEDIMENT STRUCTURES

- A. Sediment basins or traps are prepared storage areas constructed to trap and store sediment from erodible areas in order to protect downstream properties and channels from excessive siltation. Sediment basins shall be designed and constructed in accordance with the current edition of Tennessee Erosion and Sediment Control Handbook.

2.2 SILT FENCES

- A. Silt fences are woven geosynthetic materials stapled to hardwood posts spaced six to eight feet apart. They are to be staged on the construction site so as to filter runoff water and trap sediments on the site. The fences are to be set in 4-inch x 4-inch trenches that are backfilled and compacted so as to prevent undercutting of the fences.

2.3 SEEDING AND MULCHING

- A. Seeding and Mulching consists of fertilizing, seeding, mulching and/or installing erosion control blankets (ECB) as specified elsewhere utilized to prevent erosion. All areas shall be seeded with mulch or ECB within fifteen (15) days of achieving final grade.

2.4 TEMPORARY BERMS

- A. A temporary berm is constructed of compacted soil, with or without a shallow ditch, at the top of fill slopes or transverse to centerline on fills.
- B. These berms are used temporarily at the top of newly constructed slopes to prevent excessive erosion until permanent controls are installed or slopes stabilized.

2.5 TEMPORARY SLOPE DRAINS

- A. A temporary slope drain is a facility consisting of stone gutters, fiber mats, plastic sheets, concrete or asphalt gutters, half-round pipe, metal pipe, plastic pipe, sod or other material acceptable to the Engineer.
- B. Temporary slope drains are used to carry water down slopes to reduce erosion.

2.6 CHECK DAMS

- A. Check dams are barriers composed of logs and poles, large stones or other materials placed across a natural or constructed drain way.
- B. Stone check dams shall not be utilized where the drainage area exceeds fifty (50) acres. Log and pole structures shall not be used where the drainage area exceeds five (5) acres.

2.7 BRUSH BARRIERS

- A. Brush barriers shall consist of brush, tree trimmings, shrubs, plants and other approved refuse from the clearing and grubbing operations.
- B. Brush barriers are placed on natural ground at the bottom of fill slopes where the most likely erodible areas are located to restrain sedimentation particles.

2.8 BALED HAY OR STRAW CHECKS

- A. Baled hay or straw erosion checks are temporary measures to control erosion and present siltation. Bales shall be either hay or straw containing five (5) cubic feet or more of material.

- B. Baled hay or straw checks shall be used where the existing ground slopes toward or away from the embankment along the toe of slopes, in ditches, or other areas where siltation erosion or water run-off is a problem.

PART 3 - EXECUTION

3.1 PERMIT

- A. For projects which will ultimately disturb more than one (1) acre, file or sign on to a previously filed "Notice of Intent" with the Tennessee Department of Environment and Conservation's Division of Water Pollution Control (TDEC), including the payment of permit fees at least thirty (30) days prior to beginning of construction.
- B. Do not begin work prior to the receipt of the "Notice of Coverage" (NOC) from TDEC.
- C. After complete stabilization of the site, the Contractor shall file or assist the Owner in filing a "Notice of Termination" (NOT) with TDEC indicating the end of the earth disturbing activities and full stabilization of the site.

3.2 PLAN

- A. The contractor shall develop and implement a storm water pollution plan (SWPPP) specific to the project site that minimizes the erosion of soil and other pollutants to waters of the State. The plan shall include but not be limited to a description of the construction activity with a proposed timetable, estimates of total site area and area to be disturbed, estimate of increased impervious area after construction, estimate of runoff volume from a two year 24-hour storm, description of fill material used, and a specific site map with slopes, structural controls, and permanent cover to be established. The Owner, contractor, and subcontractors who may impact storm water or site controls shall sign the plan, stating that it meets requirements and is workable. The plan must be kept on site during construction.
- B. The contractor and subcontractors that may impact storm water runoff or structural controls shall sign the following statement:

"I understand the terms and conditions of Rule 1200-4-10-.05 and that I, and my company, as the case may be, am responsible for and legally liable for complying with this and the applicable state and federal laws. I understand that state, EPA or private actions may be taken against me if the terms and conditions of the Rule are not met."

Statements are to be kept on file at the site or nearby.

3.3 DOCUMENTATION

- A. Prior to any disturbance on site, the contractor shall provide to the engineer a signed copy of the notice of intent, along with evidence of the inspector certification as required by TDEC. All inspection reports required by regulation shall be attached to each following pay request. Inspection reports shall be in accordance with the current edition of Tennessee Erosion and Sediment Control Handbook.
- B. Prior to the final payment, the contractor shall provide a copy of the "Notice of Termination" (NOT) acceptance letter from the Tennessee Department of Environment and Conservation.

3.4 CONSTRUCTION

- A. Designate in writing a specific individual to be responsible for the control of erosion on the site.
- B. Clearing and grubbing are to be held to a minimum and phased to minimize exposure of cleared areas. In no case shall cleared areas exceed ten (10) acres without seeding, mulching, installing ECB, sodding or other approved method of minimizing erosion.
- C. Adequate erosion and sediment control structures are to be in place prior to any clearing or soil disturbance. They are to be maintained to ensure effectiveness throughout the project. This includes replacement, alteration, and addition of new measures.
- D. Inspections of erosion and sediment control structures shall be performed at least two (2) times every calendar week a minimum of 72 hours apart. Based on the results of the inspections, all measures shall be replaced or repaired as needed. Maintain a record book of these checks and repairs and retain for at least three years. Deliver reports to the Tennessee Department of Environment and Conservation (TDEC) as required by the permit.
- E. Install a rain gauge on site prior to initiating any clearing. Maintain a rainfall record throughout the life of the project and until the "Notice of Termination" (NOT) is filed with TDEC.
- F. Do not disturb vegetation more than ten (10) days prior to initiation of grading or earth moving. Apply vegetation within seven days for unfinished areas that will be left for more than fifteen (15) days. Apply permanent vegetation within fifteen (15) days after completion of grading in any given area, weather permitting.
- G. Divert surface water around the construction areas. Filter sediment laden water pumped from excavated work areas.
- H. After complete stabilization of all disturbed areas, the contractor shall remove all temporary erosion control measures.

3.5 CONSTRUCTION OF STRUCTURES

A. Temporary Berm

1. A temporary berm shall be constructed of compacted soil, with a minimum width of 24-inches at the top and a minimum height of 12-inches with or without a shallow ditch, constructed at the top of fill slopes or transverse to centerline on fills. Temporary berms shall be graded so as to drain to a compacted outlet at a slope drain. The area adjacent to the temporary berm near the slope drain must be properly graded to enable this inlet to function efficiently and with minimum ponding in this area.
2. All transverse berms required on the downstream side of a slope drain shall extend across the grade to the highest point at approximately a 10-degree angle with a perpendicular to centerline. The top width of these berms may be wider and the side slope flatter on transverse berms to allow equipment to pass over these berms with minimal disruptions. When practical and until final roadway elevations are approached, embankments should be constructed with a gradual slope to one side of the embankment to permit the placement of temporary berms and slope drains on only one side of the embankment.

B. Temporary Slope Drains

1. Temporary slope drains shall consist of stone gutters, fiber mats, plastic sheets, concrete or asphalt gutters, half-round pipe, metal pipe, plastic pipe, flexible rubber or other materials which can be used as temporary measures to carry water accumulating in the cuts and on the fills down the slopes prior to installation of permanent facilities or growth of adequate ground cover on the slopes.
2. Fiber matting and plastic sheeting shall not be used on slopes steeper than 4:1 except for short distances of 20 feet or less.
3. All temporary slope drains shall be adequately anchored to the slope to prevent disruption by the force of the water flowing in the drains. The base for temporary slope drains shall be compacted and concavely formed to channel the water or hold the slope drain in place. The inlet end shall be properly constructed to channel water into the temporary slope drain. Energy dissipaters, sediment basins or other approved devices shall be constructed at the outlet end of the slope drains to reduce erosion downstream.
4. An ideal dissipater would be dumped rock or a small sediment basin which would slow the water as well as pick up some sediment. All temporary slope drains shall be removed when no longer necessary and the site restored to match the surroundings.

C. Sediment Structures

1. Sediment structures shall be utilized to control sediment at the foot of embankments where slope drains outlet; at the bottom as well as in the ditch lines atop waste sites; in the ditch lines or borrow pits. Sediment structures may be used in most drainage situations to prevent excessive siltation of pipe structures. All sediment structures shall be at least twice as long as they are wide.

2. When use of temporary sediment structures is to be discontinued, all sediment accumulation shall be removed, and all excavation backfilled and properly compacted. The existing ground shall be restored to its natural or intended condition.

D. Check Dams

1. Check dams shall be utilized to retard stream flow and catch small sediment loads. Materials utilized to construct check dams are varied and should be clearly illustrated or explained in the Contractor's erosion control plan.
2. All check dams shall be keyed into the sides and bottom of the channel a minimum depth of 2-feet. A design is not needed for check dams, typical designs are shown in the standard plans.
3. Stone check dams should generally not be utilized where the drainage area exceeds fifty (50) acres. Log and pole structures should generally not be used where the drainage area exceeds five (5) acres.

E. Brush Barriers

1. Brush barriers shall consist of brush, tree trimmings, shrubs, plants, and other approved refuse from the clearing and grubbing operations. The brush barriers shall be constructed approximately parallel to original ground contour.
2. The brush barrier shall be compressed to an approximate height of 3 to 5 feet and an approximate width of 5 to 10 feet. The embankment shall not be supported by the construction of brush barriers.

F. Baled Hay or Straw Erosion Checks

1. Hay or straw erosion checks shall be embedded in the ground 4 to 6-inches to prevent water flowing under them. The bales shall also be anchored securely to the ground by wooden stakes driven through the bales into the ground. Bales can remain in place until they rot or be removed after they have served their purpose, as determined by the Engineer.
2. The Contractor shall keep the checks in good condition by replacing broken or damaged bales immediately after damage occurs. Normal debris clean-out will be considered routine maintenance.

G. Temporary Silt Fences

1. Temporary silt fences shall be placed on the natural ground, at the bottom of fill slopes, in ditches or other areas where siltation is a problem. Silt fences are constructed of wire mesh fence with a covering of burlap or some other suitable material on the upper grade side of the fence and anchored into the soil.

2. The Contractor shall be required to maintain the silt fence in a satisfactory condition for the duration of the project or until its removal is requested by the Engineer. The silt accumulation at the fence may be left in place and seeded, removed, etc. as directed by the Engineer. The silt fence becomes the property of the Contractor whenever the fence is removed.

H. Maintenance

1. The temporary erosion control features installed by the Contractor shall be maintained until no longer needed, permanent erosion control methods are installed, or complete stabilization is achieved. Materials removed shall become the property of the Contractor.

3.6 REGULATION

- A. Allow state or local inspector to enter property at any time to inspect records, controls, or pollution management and to sample at reasonable times. Notify the TDEC, WPC Director of physical alterations that can change or increase the storm water discharge.

3.7 PAYMENT

- A. Payment shall be made at the contract unit price for erosion and sedimentation control items properly installed, maintained, and accepted.
- B. Temporary erosion and pollution control measures required due to the Contractor's negligence, carelessness, failure to maintain, or failure to install permanent controls in a timely fashion, such work shall be performed by the Contractor at his own expense.

3.8 FINES

- A. The Contractor shall be responsible for the payment of any fine to the Owner because of failure on the part of the Contractor to obtain a permit, develop a (SWPPP), keep records, maintain erosion control features, be signatory to required permits and documents, contain erosion from the site and/or other actions in violation of the State of Tennessee General Permit for Storm Water Discharge from Construction Sites (NPDES Permit).

END OF SECTION 31 25 01

DIVISION 32

EXTERIOR IMPROVEMENTS

SECTION 32 12 16 – ASPHALT PAVING

PART 1 - GENERAL

1.1 RELATED DOCUMENTS

- A. Drawings and general provisions of Contract, including General and Supplementary Conditions and Division 1 Specification sections, apply to work of this section.

1.2 DESCRIPTION OF WORK

- A. Extent of asphalt concrete paving work is shown on drawings.
- B. Prepared aggregate base is specified elsewhere.

1.3 JOB CONDITIONS

- A. Weather Limitations: Apply prime and tack coats when ambient temperature is above fifty (50) degrees F, and when temperature has not been below thirty-five (35) degrees F for twelve (12)-hours immediately prior to application. Do not apply when aggregate base is wet or contains an excess of moisture.
- B. Construct asphalt concrete surface course when atmospheric temperature is above forty (40) degrees F, and when base is dry. Base course may be placed when air temperature is above thirty (30) degrees F and rising.
- C. Grade Control: Establish and maintain required lines and elevations

PART 2 - PRODUCTS

2.1 MATERIALS

- A. General: Use locally available materials and gradations which exhibit a satisfactory record of previous installations. Tennessee Department of Transportation (TDOT) approved materials and mix designs are acceptable.
- B. Surface Coarse Aggregate: Crushed stone, crushed gravel, crushed slag, and sharp-edged natural sand.
- C. Asphalt Cement: Comply with AASHTO M 320 and Tennessee Department of Transportation procedures.
- D. Viscosity Grade: AC-20, AR-80.

- E. Tack Coat: Emulsified asphalt; AASHTO M 140 (ASTM D 997) or M 208 (D 2397), SS-1, SS-1h, CSS-1, CSS-1h, TST-1P, CQS-1h, CQS-1hp, TTT-1, or TTT-2.
- F. Asphalt-Aggregate Mixture: Provide asphalt-aggregate mixture as recommended by local paving authorities to suit project conditions.

PART 3 - EXECUTION

3.1 SURFACE PREPARATION

- A. Remove loose material from compacted sub base surface immediately before applying herbicide treatment or prime coat.
- B. Notify Contractor of unsatisfactory conditions. Do not begin paving work until deficient sub base areas have been corrected and are ready to receive paving.

3.2 PRIME COAT

- A. Apply at rate of 0.20 to 0.50 gal. Per sq. yd., over compacted sub-grade. Apply material to penetrate and seal, but not flood, surface. Cure and dry as long as necessary to attain penetration and evaporation of volatile.

3.3 TACK COAT

- A. Material Application Temperatures: SS-01, SS-1h, CSS-1, CSS-1h, TST-1p, CQS-1h, CQS-1hp 60 – 140° F; TTT-1 160 - 180° F; and TTT-2 120 – 160° F.
- B. Dilution of asphalt emulsion after leaving the terminal is not ALLOWED. Apply as delivered from the terminal.
- C. Apply to clean and dry contact surfaces of previously constructed asphalt or Portland cement concrete and surfaces abutting or projecting into asphalt concrete pavement.
- D. Distribute at rate of 0.05 to 0.10 gal. per sq. yd. of surface.
- E. Allow to dry until at proper condition to receive paving.

3.4 PLACING MIX

- A. General: Place asphalt concrete mixture on prepared surface, spread and strike off. Spread mixture at minimum temperature of 225 degrees F (107 degrees C). Place inaccessible and small areas by hand. Place each course to required grade, cross section, and compacted thickness.

- B. Paver Placing: Place in strips not less than ten (10)-feet wide, unless otherwise acceptable to Architect. After first strip has been placed and rolled, place succeeding strips and extend rolling to overlap previous strips. Complete base course for a section before placing surface course.
- C. Joints: Make joints between old and new pavements, or between successive days' work, to ensure continuous bond between adjoining works. Construct joints to have same texture, density, and smoothness as other sections of asphalt concrete course. Clean contact surfaces and apply tack coat.

3.5 ROLLING

- A. General: Begin rolling when mixture will bear roller weight without excessive displacement.
- B. Compact mixture with hot hand tampers or vibrating plate compactors in areas inaccessible to rollers.
- C. Breakdown Rolling: Accomplish breakdown or initial rolling immediately following rolling of joints and outside edge. Check surface after breakdown rolling, and repair displaced areas by loosening and filling, if required, with hot material.
- D. Second Rolling: Follow breakdown rolling as soon as possible, while mixture is hot. Continue second rolling until mixture has been thoroughly compacted.
- E. Finish Rolling: Perform finish rolling while mixture is still warm enough for removal of roller marks. Continue rolling until roller marks are eliminated and course has attained maximum density.
- F. Patching: Remove and replace paving areas mixed with foreign materials and defective areas. Cut out such areas and fill with fresh, hot asphalt concrete. Compact by rolling to maximum surface density and smoothness.
- G. Protection: After final rolling, do not permit vehicular traffic on pavement until it has cooled and hardened.
- H. Erect barricades to protect paving from traffic until mixture has cooled enough not to become marked.

3.6 FIELD QUALITY CONTROL

- A. General: Test in place asphalt concrete courses for compliance with requirements for thickness and surface smoothness. Repair or remove and replace unacceptable paving as directed by Architect/Engineer.
- B. Surface Smoothness: Test finished surface of each asphalt concrete course for smoothness, using ten (10)-foot straightedge applied parallel with, and at right angles to centerline of paved area. Surfaces will not be acceptable if exceeding the following tolerances for smoothness.

1. Wearing Course Surface: 3/16-inch
 2. Binder Course: 3/8-inch
- C. Compaction: The density (bulk specific gravity) determination for a compacted asphalt mixture shall be performed in accordance with AASHTO T-166, Method A or C. Asphalt surfaces in parking lots and on private drives shall meet the following density requirements: Average Percent of Maximum Theoretical Density ≥ 92 with no single test lower than 89. For density requirements on all other asphalt surfaces refer to Section 407.15-Compaction of the TDOT Standard Specification for Road and Bridge Construction, latest edition.

END OF SECTION 32 12 16

SECTION 32 92 19 – SEEDING

PART 1 - GENERAL

1.1 WORK INCLUDED

- A. Preparation of landscape area including loosening, pulverizing and fertilizing.
- B. Placement of seed including mulch where required.
- C. Watering of landscaping.

PART 2 - PRODUCTS

2.1 SEED MATERIALS

- A. Inspect and test seed for germination and purity prior to mixing.
- B. Uniformly mix by group:

| <u>Seed Name</u> | <u>Quantity</u> <u>% By Wt.</u> |
|------------------|------------------------------------|
|------------------|------------------------------------|

Group "A"

| | |
|------------------------------------|-----|
| Lespedeza (common or Korean) | 20% |
| Sericea Lespedeza | 15% |
| Kentucky 31 Fescue..... | 40% |
| English Rye | 25% |

Group "B"

| | |
|-------------------------|-----|
| Kentucky 31 Fescue..... | 55% |
| Redtop..... | 15% |
| English Rye | 30% |

Group "C"

| | |
|-------------------------|-----|
| Sericea Lespedeza | 50% |
| Kentucky 31 Fescue..... | 30% |
| English Rye | 20% |

- C. Use Group "A" seed from February 1 to August 1.
- D. Use Group "B" seed from August 1 to December 1, with the exception that either Group "A" or "B" may be used during the month of August.

- E. Use Group "C" seed from February 1 to December 1 only when specified on the plans or otherwise approved.
- F. All seed shall meet the requirements of the Tennessee Department of Agriculture.
- G. Furnish the Engineer a certified laboratory report showing the analysis of the seed to be furnished. The report shall bear the signature of a senior seed technologist.
- H. Inoculants for Legumes:
 - 1. Nitrogen fixing bacteria cultures adapted to the particular seed to be treated.
 - 2. Furnish in containers of a size sufficient to treat the specified quantity of seed to be planted.

2.2 MULCH MATERIALS

- A. Hay composed of approved stalks from grasses, sedges, or legumes; or straw composed of stalks from rye, oats, wheat, or other approved grains.
- B. Air dried and reasonably free from noxious weeds, weed seeds, and other detrimental plant growth.
- C. Suitable for spreading with mulch blower machinery.
- D. Wood fiber mulch, when used, shall meet the following specifications:
 - 1. Moisture Content 10% +/- 2%
 - 2. Organic Matter 99.4% +/- 0.2%
 - 3. Ash Content 0.6% +/- 0.2%
 - 4. Water Hold Capacity 1050 grams min. (Per hundred grams of oven dry fiber)
- E. Mulch Binders:
 - 1. Cut back asphalt, Grade RC-70 or RC-250 conforming to AASHTO M-81, M-82 or M-141, for the type and grade specified.
 - 2. Emulsified asphalt, Type SS-1 conforming to AASHTO M-140. In addition to Type SS-1, a special mixing material AE-3 or a special priming material AE-P may be specified.

2.3 JUTE MESH

- A. Open plain weave of single jute yarn and nontoxic to vegetation.
- B. Tag jute rolls for identification with 58 warp ends per yard, 41 weft ends per yard and weighing approximately 0.9 pounds per square yard with an acceptable tolerance of 5 percent.
 - 1. **Staples:** New and unused, machine made of No. 11 gauge steel wire formed into a "U" shape.

2.4 COMMERCIAL FERTILIZERS

- A. Unless otherwise specified, inorganic 10-20-10 nitrogen, phosphoric acid, and potash for seeding and 15-15-15 or 1-1-1 for sodding.
- B. Furnish in standard containers with the brand name, weight and guaranteed analysis of the contents clearly marked.
- C. Comply with Federal, State, and local laws.
- D. Ammonium nitrate shall be a standard commercial product, having a minimum of 33.5 percent nitrogen.
- E. Agricultural limestone shall contain a minimum of 85% of calcium carbonate and magnesium carbonate combined and is of particular size that 85% will pass a No. 10 mesh sieve.
 - 1. **Water:** Free from harmful organisms or other objectionable materials.

2.5 TOPSOIL

- A. Natural, friable fertile, fine sandy loam possessing characteristics of representative topsoils in the vicinity which produce heavy growths of vegetation.
- B. Free from subsoil, noxious weeds, and stones larger than one inch in diameter, lime, cement, ashes, slag or other deleterious matter.
- C. Well drained in its original position and free from toxic quantities of acid or alkaline elements.

PART 3 - EXECUTION

3.1 SEEDING

- A. Scarify, disc, harrow, rake, or otherwise work each area to be seeded until it has been loosened and pulverized to a depth as directed by the Engineer.
- B. Uniformly incorporate fertilizer into the soil for a depth of approximately 1/2" at the rate of:
 - 1. Not less than 20 lbs. per 1,000 square feet for grade 10-10-10 or equivalent.
 - 2. Not less than 100 lbs. per 1,000 square feet for agricultural limestone.
- C. Fertilizer need not be incorporated in the soil as specified above when mixed with seed in water and applied with power sprayer equipment.
 - 1. Sow seed of the specified group as soon as preparation of the seedbed has been completed

- D. Sow uniformly by means of a rotary seeder, hydraulic equipment, or other satisfactory means at the rate of 3.5 pounds per 1,000 square feet, unless otherwise specified.
- E. Inoculate Group "C" seed and seeds of legumes, when sown alone, before sowing in accordance with the recommendations of the manufacturer or the inoculants.
- F. Do not perform seeding during windy weather, or when the ground surface is frozen, wet or otherwise non-tillable. No seeding shall be performed during December through February unless otherwise permitted.
- G. Provide seeding with mulch:
 - 1. Spread hay or straw mulch evenly over the seeded area at an approximate rate of 90 pounds per 1,000 square feet immediately following the seeding operation. This rate may be varied by the Engineer, depending on the texture and condition of the mulch material and the characteristics of the area seeded.
 - 2. Hold hay or straw mulch in place by the use of a mulch binder applied at the approximate rate of 4 gallons per 1,000 square feet as required.
 - 3. Cover bridges, guardrails, signs and appurtenances if the mulch binder is applied in such a way that it would come in contact with or discolor the structures.
 - 4. When wood fiber mulch is used, uniformly apply at the rate of 28 to 35 pounds per 1,000 square feet with hydraulic mulching equipment.

3.2 TOPSOIL

- A. Prepare landscape area to receive topsoil in close conformity to the lines and grades shown on the drawings.
- B. Place topsoil at depths and locations shown on the drawings.

3.3 MAINTENANCE SERVICES

- A. Contractor shall perform maintenance services.
- B. Begin maintenance immediately after planting.
- C. Maintain seeded areas for not less than sixty (60) days. If seeded in the fall, maintain through the following spring until an acceptable lawn is established.
- D. Maintain seeded areas by watering, fertilizing, weeding, mowing, and replanting as required to establish a smooth, acceptable lawn, free of eroded or bare areas. Minimum coverage is 90% for seeded areas.

3.4 INSPECTION AND ACCEPTANCE

- A. When landscape work is completed, including maintenance, Architect will, upon request, inspect to determine acceptability.
- B. When landscape work does not comply with requirements, replace rejected work and continue specified maintenance until re-inspected by Architect and found acceptable. Remove rejected plants and materials promptly from project site.

3.5 MEASUREMENT AND PAYMENT

- A. Costs associated with seeding will be included in the lump sum contract. No separate payment shall be made for seeding.

END OF SECTION 32 92 19

DIVISION 33

UTILITIES

SECTION 33 10 00 – WATER DISTRIBUTION SYSTEMS

PART 1 - GENERAL

1.1 WORK INCLUDED

- A. Installation, testing and disinfection of water lines and appurtenance

1.2 RELATED WORK

- A. SECTION 31 23 00: Backfilling, Trenching and Compaction
- B. SECTION 33 21 00: Separation of Piped Utilities

1.3 SUBMITTALS

- A. Submit manufacturer's installation instructions.
- B. Obtain approval from owner and/or engineer of all materials to be used on the job for conformity to Owner's specifications or accepted material brands or manufactures.

PART 2 - PRODUCTS

2.1 MATERIAL

- A. Owner accepts only AWWA approved material for installation in the water distribution system. To minimize the necessary stockpile of repair parts, standardize material and assure proven manufactures, the Owner's has compiled a list of approved brands for specific items. Periodic review of accepted material will ensure competitive prices. Only new, unused material properly stored shall be used.

2.2 POLYVINYL CHLORIDE PIPE (PVC) AND FITTINGS

- A. Provide PVC pipe meeting ASTM D-2241 or AWWA C900.
- B. ASTM D-2241 Pipe:
 - 1. Manufactured from virgin, National Sanitation Foundation (NSF) approved Type 1, Grade 1 impact improved resin suitable for use in transporting potable water.
 - 2. Pipe and fittings pressure rated for 200 psi.
 - 3. Use only where the maximum pressure shall not exceed 2/3 of the pressure rating or 135 psi.
 - 4. Maximum Standard Dimension Ratio (SDR) of 21.

5. Joints sealed with a rubber ring and nontoxic lubricant as provided by the manufacturer meeting or exceeding the requirements of ASTM D-3139 and ASTM F-477.
6. Clearly mark with the manufacturer's name, nominal diameter, SDR, ASTM D-2241, pressure rating, and NSF approval seal.

C. AWWA C900 Pipe:

1. PVC 1120 pipe manufactured from virgin, National Sanitation foundation (NSF) approved compounds meeting the requirements of ASTM D-1784.
2. Pressure rated based on Dimension Ratios (DR) and pressure classes (pressure classes are working pressure ratings):

| <u>Dimension Ratio (DR)</u> | <u>Pressure Class (psi)</u> |
|-----------------------------|-----------------------------|
| 25 (for force mains only) | 165 |
| 18 | 235 |
| 14 | 305 |

3. Outside diameter equivalent to the same outside diameter of cast iron pipe.
4. The minimum wall thickness of the bell, at any point, shall conform with the DR requirements of the pipe.
5. Furnish in standard laying lengths of twenty (20) feet.
6. Clearly mark with the manufacturer's name, nominal diameter, DR, PVC 1120, pressure class, AWWA C900, and NSF approved seal.

2.3 DUCTILE IRON PIPE AND FITTINGS

A. Pipe:

1. Manufactured in accordance with ANSI/AWWA C151/A21.50-86 and ANSI/AWWA C110/A21.10-87.
2. A cement lining meeting the requirements of ANSI/AWWA C104/A21.4-85.
3. A minimum of 1 mil thick bituminous coating on the outside surface.
4. Clearly mark with manufacturer's name, D.I. or Ductile, weight, class or nominal thickness, and casting period.
5. Unless otherwise specified or shown on the plans, ductile iron pipe shall be Class 50 for 200 psi working pressure.

B. Fittings:

1. Fittings 4 inches through 12 inches shall be cast from ductile iron in accordance with ANSI/AWWA C153/A21.53-88 with mechanical joint bell. Glands, bolts, nuts, and gaskets shall be in accordance with requirements of ANSI/AWWA C153/A21.53-88. The working pressure rating shall be 350 psi. Fittings shall have an asphaltic outside coating in accordance with ANSI/AWWA C153/A21.53-88.
2. Fittings 14 inches through 24 inches shall meet ANSI/AWWA C111/A21.11-85. The working pressure rating shall be 350 psi. Fittings shall have an asphaltic outside coating in accordance with ANSI/AWWA C111/A21.11-85.

3. Fittings 30 inches through 36 inches shall meet ANSI/AWWA C111/A21.11-85 with mechanical joint bell. Glands, bolts, nuts, and gaskets shall be in accordance with requirements of ANSI/AWWA C111/A21.11-85. The working pressure rating shall be 250 psi. Fittings shall have an asphaltic outside coating in accordance with ANSI/AWWA C111/A21.11-85.
 4. Fittings shall be cement lined and seal coated with an asphaltic material in accordance with ANSI/AWWA C104/A21.4-85.
 5. Weights of fitting shall be determined on the weight of fitting tables in ANSI/AWWA C104/A21.53-88.
 6. Fire hydrant-to main connection fittings for 16-inch and larger mains, these fittings shall be ductile iron tapping saddles, with flange side outlets; for 12-inch and sampler mains, these fittings shall be mechanical joint anchoring tees with spigot side outlets having locked-on rotatable glands.
 7. Openings in pipe to accommodate tapping saddles: cut these openings with a suitable tapping machine, torch cutting will not be permitted.
- C. Certificates: Submit in duplicate certificates from the manufacturer certifying that all pipe and fittings furnished for this project comply with these specifications.

2.4 SERVICE PIPE

A. Copper Pipe:

1. Seamless copper tubing meeting the requirements of ASTM B-88, Type K.
2. Contain not less than 99.90% copper and not more than 0.04% phosphorous.
3. Suitable for use with a working water pressure of 160 psi.
4. ¾-inch nominal diameter unless otherwise specified or shown on the Plans.
5. Service pipe shall be used to connect the corporation stop with the meter yoke. Use the minimum length required to make a straight-line connection including a gooseneck.

B. Polyethylene Pipe:

1. Class 160, SDR 9, polyethylene classified PE 3406C suitable for a working pressure of 160 psi.
2. 100% nontoxic polyethylene resin compound of ultra-high molecular weight in accordance with ASTM D-1248.
3. ¾-inch nominal diameter unless otherwise specified or shown on the plans.
4. Service pipe shall be used to connect the corporation stop with the meter yoke. Use the minimum length required to make a straight-line connection including a gooseneck.

2.5 WATER SERVICE ASSEMBLIES

A. Water Meters:

1. AWWA C700.
2. 5/8" x 3/4" unless otherwise specified or shown on the Plans.
3. Frost proof with a cast bronze casing and a hinged cover.

4. Direct reading register, in gallons, unless otherwise specified.
5. Disc or piston operated with magnetic drive.
6. A suitable non-corrosive strainer located over the inlet to the measuring chamber.
7. The name of the manufacturer cast in the lid of the register box and the meter serial number imprinted thereon.
8. Brand to be as required by system owner.

B. Water Main Connections:

1. Tap water mains in the upper half of the pipe at a 45-degree angle or provide brass tapped couplings with AWWA threads.
2. Do not exceed the pipe manufacturer's recommended maximum tap size.
3. Use service clamps on all taps for PVC.

C. Corporation Stops:

1. AWWA C800, Ford No. F 1000 or approved equal.
2. Cast of certified waterworks red brass, composed of 85% copper and 5% each of tin and zinc.
3. Watertight and individually tested for leaks.
4. Waterway diameter approximately equal to the nominal size of the stop.
5. Coat or cap all threads for protection prior to installation.

D. Meter Yokes

1. Ford No. V172 - with BA 13-332R Angle Ball Valve CTS-PJ Inlet and Outlet or approved equal.
2. Copper tubing with an integral brace and meter stop.
3. Minimum rise of 14-inch, 7-inch for $\frac{3}{4}$ -inch and 10-inch for 1-inch.
4. Provide with outlets designed for the use of copper service pipe.

E. Service Clamps: Bronze with neoprene gasket and double straps.

F. Meter Boxes:

1. Rectangular precast concrete or plastic per Owner requirements.
2. Pre-cast concrete meter boxes shall have a cast iron lid.
3. Depth of the meter box not less than 15 inches.
4. Of sufficient size to facilitate easy installation and removal of the water meter.
5. Where service assemblies include a pressure reducing valve, sufficiently sized for installation of the pressure reducing valve in the meter box.

2.6 VALVES AND VALVE BOXES

A. Resilient Seated Gate Valves

1. Valve shall conform to the latest AWWA C509.
2. Of iron body, non-rising bronze stem type.

3. Waterway shall be smooth and shall have no depressions or cavities on seat area where foreign matter can lodge and prevent closure.
4. The stem shall be sealed by a minimum of two O-rings; all stem seals shall be replaceable with the valve wide open and while subjected to full rated pressure.
5. 2-inch square wrench nut for operation of the valve.
6. Minimum design working water pressure of 200 psi for valves with diameters 2-inch to 12-inch, unless otherwise specified or shown on the Plans.
7. Valve body and bonnet shall be epoxy coated, inside, and out in accordance with the latest AWWA specification C550.
8. Joints: ANSI/AWWA C111/A21.11-85
9. Bonnet or body markings: Manufacturer's name, year of casting, size, pressure rating, and OPEN with direction.
10. Open left only.

B. Butterfly Valves:

1. AWWA C504
2. Cast iron body, rubber seated tight-closing type.
3. Cast markings: valve size, manufacturer's name, class, direction opening, and the year of casting.
4. Class 150, suitable for working water pressure of 150 psi unless otherwise specified or shown on Plans.
5. Open left only.

C. Main Line Pressure Reducing Valves:

1. Cast iron globe body, full bronze mounted, external pilot operator, single resilient seat type.
2. Packed with leather (or other soft material) to ensure tight closure and to prevent metal to metal friction and seating.
3. Open when the downstream pressure is less than the valve setting and close tightly when the downstream pressure exceeds the valve setting.
4. Valve opening: proportional to the delivery requirements and not influenced by changes in inlet pressure.
5. Pilot valve: arranged to allow for its removal from the main valve while under pressure and easily assessable without removal of springs, weights, or the use of special tools.
6. Suitable to operation at 200 psi working water pressure and adjustable.

D. Valve Boxes:

1. Cast iron, 3-piece, screw type with shaft diameter of not less than 5 1/4-inch with base for Gate Valve Only.
2. Cast iron, 2-piece, slide type with shaft diameter of not less than 5 ¼-inch for Butterfly Valve Only.
3. Heavy roadway type equipped with a cover containing the word "WATER" in raised letters on the top.
4. Base of such size as to permit its installation without allowing it to come in contact with either the valve or the pipe.

- E. Tapping Sleeves
 - 1. Body shall be Stainless Steel 18-8 Type 304 full circle sleeve
 - 2. Bolts shall be Stainless Steel 18-8 Type 304
 - 3. Flange shall be CFA Cast Stainless Steel or equivalent 304 Stainless Steel. Flange outlets shall be indexed per MSS-Sp60 to accept tapping valve and have the equivalent O.D. and drilling as Class 125 Cast-Iron Flanges (ANSI/ASME B16.1) and Class 150 Steel-Ring Flanges (ANS/ASME B16.5) or Engineer approved equal.
 - 4. Branch outlet shall be Schedule 10 Stainless Steel Pipe Type 304.
 - 5. Tapping Sleeve shall include a Nitrile Butadiene Rubber (NBR, Buna-N) per ASTM D2000.
 - 6. Service rating for tapping sleeves: 2" – 12" outlet 175 psi

2.7 AIR RELEASE ASSEMBLIES

- A. Furnish in 1-inch nominal diameter for 8-inch mains and smaller and in 2-inch nominal diameter for 10-inch mains and larger, unless otherwise specified or shown on the Plans.
- B. Air release assemblies shall consist of:
 - 1. Double strap, bronze service clamp with neoprene gasket (for PVC lines).
 - 2. Galvanized steel pipe of the nominal diameter required by the main size.
 - 3. Red brass corporation stop.
 - 4. Galvanized steel elbow.
 - 5. Gate valve.
 - 6. Air release valve.
- C. Combination air release valves consisting of:
 - 1. An air and vacuum valve coupled with an air release valve.
 - 2. Cast iron body, stainless steel float, bronze linkage, bronze trim, suitable for use in mains having a working pressure of 200 psi.
- D. Install in a precast concrete manhole, 48-inch in diameter and 48-inch deep, with 24-inch nominal diameter cast iron frame and cover.
- E. Place crushed stone from the top of the main to 12-inch below the bottom of the main.

2.8 FIRE HYDRANTS AND BLOW-OFF HYDRANTS

- A. Fire Hydrants:
 - 1. AWWA C502 (M&H NO. 129 or Approved Equal).
 - 2. Cast iron bodies, fully bronze mounted, designed for operation at a working water pressure of 150 psi.
 - 3. Furnish with two 2½-inch threaded brass hose nozzles and one threaded brass pumper nozzle.
 - 4. Compression type main valve 5¼-inch or 4½-inch in diameter faced with a suitable yielding material such as rubber, leather, or balata.

5. So designed that, when it is installed, no excavation is required to remove the main valve or the movable parts of the drain valve.
6. Inside diameter of barrel: at least 120 percent of the hydrant valve size.
7. Inlet connection: minimum of 6-inch mechanical joint on all lines, unless otherwise specified or shown on the Plans.
8. Equipped with safety flange located not more than 2-inches above ground and a two-piece shaft break-away assembly.
9. Open on counterclockwise operation, unless otherwise specified.
10. Shop paint and mark in accordance with AWWA C502. Color - red.
11. Cast markings: manufacturer's name, size of the main valve, year of manufacture, and direction of opening.
12. Field touch-up, if the surface has been marred, with paint supplied by the manufacturer of the same color and type as that used during shop painting.
13. Hydrants shall be of the lubricated dry top breakaway traffic type, each complete with: 4¼-inch minimum valve opening for areas classified by the Owner as "residential", and 5¼-inch valve opening for areas classified by the Owner as "non-residential"; 6-inch AWWA Specification C111 mechanical joint inlet connection; 48-inch depth of bury; two 2½-inch and one 4½-inch National Standard thread nozzles; 1½-inch pentagon operating and cap nuts; COUNTER-CLOCKWISE direction of opening; nozzle caps and chains; automatic drain valve; asphalt varnish shop coats on inside and below ground outside; and enamel shop coat above ground outside.
14. Before ordering hydrants, obtain Owner's classification of "residential" and "non-residential" areas, and furnish hydrants accordingly.

B. Blow-off Hydrants:

1. Post type having cast iron bodies, fully bronze mounted and designed for operation at a working water pressure of 150 psi.
2. Furnish one 2 ½ " threaded brass hose nozzle.
3. Compression type main valve 2 1/8-inch minimum diameter faced with a suitable yielding material such as rubber, leather, or balata.
4. So designed that, when it is installed, no excavation is required to remove the main valve or the movable parts of the drain valve.
5. Inside diameter of barrel: at least 3-inch.
6. Inlet connection: 2-inch mechanical joint, unless otherwise specified or shown on the Plans.
7. Equipped with a safety flange located not more than 2-inches above the ground.
8. Open on counterclockwise operation, unless otherwise specified.
9. Cast markings: manufacturer's name, size of the main valve, year of manufacture, and direction of opening.
10. Field touch-up, if the surface has been marred, with paint supplied by the manufacturer of the same color and type as that used during shop painting.

2.9 MISCELLANEOUS

- A. Fire hydrant-to-main connection fittings: for 16-inch and larger mains, these fittings shall be ductile iron tapping saddles, with flanged side outlets; for 12-inch and smaller mains, these

fittings shall be mechanical joint anchoring tees with spigot side outlets having locked-on rotatable glands.

- B. Openings in pipe to accommodate tapping saddles: cut these openings with a suitable tapping machine; torch cutting will not be permitted.
- C. Joints: These shall conform to AWWA Specification C111, with plain rubber gaskets; fittings shall have mechanical joints only; pipe shall have mechanical or push-on joints; except where flanged joints are specified or indicated.
- D. After completion of all water line work and before the work will be accepted, make a final check of each valve and hydrant installed in this project, and of each existing valve that has been operated in connection with the work under this project.
- E. Make this final check in the owner's presence and demonstrate that each valve is in the fully open position and that each hydrant operates properly.
- F. Local utility personnel may only operate the valve(s) connecting the project with the existing city facilities.
- G. All existing waterlines shall remain operational throughout the construction period or until final acceptance of the replacement line. Under no circumstances shall any customer be cut off from potable water for more than two (2) hours at any time. Any temporary water supply required shall be considered incidental to the job and at no additional cost to the Owner.
- H. Repairs to all existing utilities not included in this contract shall be considered incidental to the job and will be completed by the Contractor in a timely manner at no additional cost to the Owner.

PART 3 - EXECUTION

3.1 PREPARATION

- A. Prior to laying pipe, prepare suitable bedding according to Section 31 20 01.
- B. Before placing pipe in the trench, field inspect for cracks or other defective pipe from the construction site.
- C. Swab the interior of the pipe to remove all undesirable material.
- D. Prepare the bell end and remove undesirable material from the gasket and gasket recess.
- E. Lower main as necessary such that operating nut valves is 18-inch minimum below finished grade.
- F. Locate water lines in relation to other piped utilities in accordance with Section 33 21 00.

3.2 INSTALLING WATER LINES

- A. Lay all pipe in a straight line on a uniform grade.
- B. After applying gasket lubricate, take extreme care to keep the spigot end from contacting the ground.
- C. Hone the pipe with suitable tools or equipment.
- D. Closely follow the manufacturer's instruction in laying and joining pipe.
- E. Cut pipe for inserting valves, fittings, etc. in a neat and workmanlike manner without damaging the pipe so as to leave a smooth end at right angles to the axis of the pipe.
- F. Locate water lines in relation to other piped utilities in accordance with Section 33 21 00.

3.3 INSTALLING APPURTENANCES

- A. Securely plug open ends of pipe at the close of each workday and during temporary discontinuance of pipe laying.
- B. Set all valves, fittings, hydrants, and other specials in a neat workmanlike manner.
- C. Use thrust blocks, as shown on the Plans, pipe anchors, or other approved means to prevent displacement of other fittings. Vertical bends shall be constructed with approved restrained joints.
- D. Erect hydrants to stand plumb with the pumper nozzle facing the road. Centerline of the nozzle shall be between 18-inch and 24-inch above proposed grade.
- E. Close dead ends with cast iron plugs or caps and equip with blow-off assemblies, where shown on the Plans.

3.4 HIGHWAY AND RAILWAY CROSSINGS

- A. Perform highway crossings by the open cut method, unless otherwise shown on the Plans or required by the appropriate authorities.
- B. Boring and jacking of crossings, if necessary, will be performed and paid for in accordance with Section 33 32 00.
- C. All disturbed roadways shall remain open and passable throughout the construction period.

3.5 WATER LINE PRESSURE TESTS

- A. After the pipe has been laid, subject all newly laid pipe or any valved section thereof to a hydrostatic pressure of at least 150 psi or 1.5 times the working pressure at the point of testing, whichever is greater.
- B. Test pressures shall:
 - 1. Not be less than 1.25 times the working pressure at the highest point along the test section.
 - 2. Not exceed the pipe or thrust restraint design pressures.
 - 3. Be of at least 2-hour duration.
 - 4. Not vary by more than ± 5 psi.
 - 5. Not exceed twice the rated pressure of closed valves or hydrants included in the test section.
 - 6. Not exceed the rated pressure of resilient-seated butterfly valves.
- C. Pressurization:
 - 1. Slowly fill each valved section of pipe with water.
 - 2. Apply the specified test pressure, based on the elevation of the lowest point of the line or section under test and correct to the elevation of the test gauge by means of a pump connected to the pipe in a manner satisfactory to the Owner.
- D. Air Removal
 - 1. Before applying the specified test pressure, expel air completely from the pipe, valves, and hydrants.
 - 2. If permanent air vents are not located at all high points, install corporation cocks at such points to expel air as the line is filled with water.
 - 3. After all the air has been expelled, close the corporation cocks and apply the test pressure.
 - 4. At the conclusion of the pressure test, remove the corporation cocks and plug or leave in place at the discretion of the Owner.
- E. Examination:
 - 1. Carefully examine all exposed pipes, fittings, valves, hydrants, and joints.
 - 2. Repair or replace any damaged or defective pipe, fittings, valves, or hydrants that are discovered with sound material and repeat the test until it is satisfactory to the Owner.
- F. All testing shall be at the Contractors expense. Testing shall include all equipment, material, and labor involved in testing and is not a pay item.

3.6 WATER LINE LEAKAGE TEST

- A. Concurrently conduct a leakage test with the pressure test.

- B. Leakage Defined: the quantity of water that must be supplied into the newly laid pipe to maintain the specified test pressure after the air in the pipeline has been expelled and the pipe has been filled with water.
- C. Allowable Leakage:
1. Determine allowable leakage by: $L = ND/P \cdot 7400$
 2. Where L is the allowable leakage, in gallons per hour; N is the number of joints in the tested pipeline; D is the nominal diameter of the pipe, in inches; and P is the average test pressure during the leakage test, in psig.
 3. Allowable leakage at various pressures:
 4. When testing against closed metal-seated valves, an additional leakage per closed valve of 0.078 gal/hr/in. of nominal valve size shall be allowed.
 5. When hydrants are in the test section, test against the closed hydrant.
- D. All testing shall be at the Contractor expense. Testing shall include all equipment, material, and labor involved in testing and is not a pay item.

| ALLOWABLE LEAKAGE PER 1,000 FT OF PIPELINE | | | | | | | | | | | | | | | | |
|--|--|------|------|------|------|------|------|------|------|------|------|------|------|------|------|----|
| Average Test | (GALLONS PER HOUR) NOMINAL PIPE DIAMETER - INCHES | | | | | | | | | | | | | | | |
| | PSI | 2 | 3 | 4 | 6 | 8 | 10 | 12 | 14 | 16 | 18 | 20 | 24 | 30 | 36 | 42 |
| 450 | 0.32 | 0.48 | 0.64 | 0.95 | 1.27 | 1.59 | 1.91 | 2.23 | 2.55 | 2.87 | 3.18 | 3.82 | 4.78 | 5.73 | 6.69 | |
| 400 | 0.30 | 0.45 | 0.60 | 0.90 | 1.20 | 1.50 | 1.80 | 2.10 | 2.40 | 2.70 | 3.00 | 3.60 | 4.50 | 5.41 | 6.31 | |
| 350 | 0.28 | 0.42 | 0.56 | 0.84 | 1.12 | 1.40 | 1.69 | 1.97 | 2.25 | 2.53 | 2.81 | 3.37 | 4.21 | 5.06 | 5.90 | |
| 300 | 0.26 | 0.39 | 0.52 | 0.78 | 1.04 | 1.30 | 1.56 | 1.82 | 2.08 | 2.34 | 2.60 | 3.12 | 3.90 | 4.68 | 5.46 | |
| 275 | 0.25 | 0.37 | 0.50 | 0.75 | 1.00 | 1.24 | 1.49 | 1.74 | 1.99 | 2.24 | 2.49 | 2.99 | 3.73 | 4.48 | 5.23 | |
| 250 | 0.24 | 0.36 | 0.47 | 0.71 | 0.95 | 1.19 | 1.42 | 1.66 | 1.90 | 2.14 | 2.37 | 2.85 | 3.56 | 4.27 | 4.99 | |
| 225 | 0.23 | 0.34 | 0.45 | 0.68 | 0.90 | 1.13 | 1.35 | 1.58 | 1.80 | 2.03 | 2.25 | 2.70 | 3.38 | 4.05 | 4.73 | |
| 200 | 0.21 | 0.32 | 0.43 | 0.64 | 0.85 | 1.06 | 1.28 | 1.48 | 1.70 | 1.91 | 2.12 | 2.55 | 3.19 | 3.82 | 4.46 | |
| 175 | 0.20 | 0.30 | 0.40 | 0.59 | 0.80 | 0.99 | 1.19 | 1.39 | 1.59 | 1.79 | 1.98 | 2.38 | 2.98 | 3.58 | 4.17 | |
| 150 | 0.19 | 0.28 | 0.37 | 0.55 | 0.74 | 0.92 | 1.10 | 1.29 | 1.47 | 1.66 | 1.84 | 2.21 | 2.76 | 3.31 | 3.86 | |
| 125 | 0.17 | 0.25 | 0.34 | 0.45 | 0.67 | 0.84 | 1.01 | 1.18 | 1.34 | 1.51 | 1.68 | 2.01 | 2.52 | 3.02 | 3.53 | |
| 100 | 0.15 | 0.23 | 0.30 | 0.40 | 0.60 | 0.75 | 0.90 | 1.05 | 1.20 | 1.35 | 1.50 | 1.80 | 2.25 | 2.70 | 3.15 | |

*For mechanical or push-on joint pipe with 18-foot nominal lengths. To obtain recommended allowable leakage for pipe with 29-ft. nominal lengths, multiply the leakage calculation from the above table by 0.90. If the pipeline under test contains sections of various diameters, the allowable leakage will be the sum of the computed leakage for each size.

3.7 ACCEPTANCE OF INSTALLATION

- A. If any test of pipe laid disclosed leakage greater than that specified above, locate and repair the defective material until the leakage is within the specified allowance.

- B. Repair all visible leaks regardless of the amount of leakage.

3.8 CLEANING AND DISINFECTION OF WATER LINES

- A. Flush water lines clean prior to disinfection.
- B. Thoroughly disinfect water lines prior to placing in service.
 1. Use chlorine disinfecting agent applied to produce a 50-ppm dosage.
 2. Allow water to escape from the ends of all lines to cause dispersion of the chlorine solution into all parts of the system.
 3. Operate all valves and Hydrants during the time disinfection is occurring.
 4. Retain the chlorine solution in the lines for a period of 24 hours.
 5. At the end of the 24-hour period, the residual chlorine must be a minimum of 25 ppm. Otherwise, repeat the disinfection procedure again.
 6. Upon refilling the lines, collect a sample for bacteriological analysis. If the same is acceptable, the lines may be connected to the system. Otherwise repeat the disinfection procedure until acceptable samples are obtained.

3.9 PIPE LOCATING TAPE & TRACER WIRE

- A. Provide pipe locating tape over all non-metallic pipes, to facilitate locating the pipe with metal detecting devices.
- B. Tape shall be "Terra Tape Sentry Line Detectable" as manufactured by Reef Industries, Inc. Houston, Texas, 1-800-234-6074" or approved equal plastic type with metalized core and continuous imprints reading "CAUTION BURIED WATER LINE BELOW" with a minimum width of six (6) inches. Tape shall provide for continuity along its full length.
- C. Install the tape in pipe trenches during backfilling operations directly over the pipe, between 12-inch minimum and 18-inch maximum below finished grade, except that tape is not required over pipes in metal casings.
- D. #12 Copper Tracer wire shall be installed on all non-metallic water mains and water services. The wire shall be installed in such a manner as to be able to properly trace all water mains and water services without loss or deterioration of signal or without the signal migrating off the tracer wire. The wire shall be protected from damage during the excavation or backfilling of the Works. No breaks or cuts in the tracer wire or tracer wire insulation shall be permitted during installation or backfill. Continuity tests shall be conducted by the contractor. Testing shall be done in the presence of and to the satisfaction of the engineer/owner. Tracing wire installations that fail the continuity testing shall be corrected and retested to the satisfaction of the engineer/owner. The contractor shall provide the engineer with sufficient notification of any testing.
- E. No specific payment will be made for pipe locating tape or tracer wire. The cost is incidental and should be included in other items.

3.10 AS BUILT DRAWINGS

- A. The Contractor shall provide a complete set of Record As-Built Drawings. They shall include actual field angles between lines, all actual service lines and tee locations, the distance of the end of service lines to property corners and lines, the depth to top of the end of the service line and shall reflect all alignment and grade changes. This item must be completed and submitted prior to acceptance of the water mains into the public system and any connections being made thereto.

DO NOT, UNDER ANY CIRCUMSTANCES, OPEN THE VALVES BETWEEN THE EXISTING MAINS AND THE NEW MAINS UNTIL THE BACTERIAL ANALYSIS OF THE MAINS INVOLVED HAS BEEN APPROVED BY THE ENGINEER. EXCEPT THAT UPON ENGINEER'S APPROVAL, VALVES MAY BE OPENED ONLY AS REQUIRED TO ADMIT WATER INTO THE NEW MAINS FOR TESTING, DISINFECTION, AND FLUSHING.

3.11 CLEANING UP OF DISTRIBUTION SYSTEM

- A. Clean up the distribution system as the work progresses. Negligence in proper cleaning up which causes undue inconvenience to the public or presents an unsightly or dangerous condition will be sufficient reason for rejection of construction estimates until the unsatisfactory condition is remedied.
- B. After completion of all work, make a final cleanup of all areas where work has been done, and leave same in a clean condition.

3.12 FINAL VALVE CHECK

- A. After completion of all work under this Contract and before the work is accepted and before final payment, the Contractor shall make a final check of each valve installed under this Contract, and of each existing valve that has been operated in connection with the work under this Contract.
- B. Make this check in the presence of the Engineer; demonstrate that each valve is in a fully open position, and that each hydrant operates properly.

3.13 PAYMENT AND MEASUREMENT OF PAYMENT

- A. Pipe: Paid for at the unit price per linear foot of pipe in place, measured along the top center line of the pipe between intersecting centerline or ends of pipe, through fittings and valves, and leads to fire hydrants. No vertical runs of pipe are included in this item.
- B. Fittings: Paid by the unit price provided for each pound of fitting installed.
- C. Thrust Blocking: No separate payment will be made for concrete required to install thrust blocking. All costs shall be included in the cost of pipe installation.

- D. Valves and Boxes: Paid for at the unit price for each valve and its box in place.
- E. Flushing Hydrant: Paid for at the unit price for each flushing assembly in place, complete with base supports, drainage gravel, anchorage, painting based upon standard 3-foot bury hydrants to include valve, and valve box as indicated on the technical drawing.
- F. Foundation Gravel: Paid for at the unit price per cubic yard of compacted gravel or crushed rock in place as evidenced by delivery tickets signed by the Engineer.
- G. Miscellaneous Concrete: Paid for at the unit price per cubic yard of 3000 psi concrete in place as evidenced by delivery tickets signed by the Engineer. Does not include concrete required for thrust blocking
- H. Placement of Road Gravel: included in the square yard price for pavement repair.
- I. Placement of Asphalt Surface: Paid for at the unit price per square yard of plant mix asphalt in place, including gravel base.
- J. Placement of Surface Treatment Surfaces: Paid for at the unit price per square yard of double bituminous surface treatment in place.
- K. Joint Materials, Excavation and Backfill, Removal of Paving, Anchorage, Testing and Sterilizing, Removing and Replacing Sod, Fences, Etc.: No separate payment; to be included in the unit price for pipe.
- L. Extra Depth Excavation: No payment will be made for extra depth excavation that may be required to pass under obstructions, whether indicated on drawings or not.
- M. Connection to Existing Line:
 - 1. Wet Taps shall be paid for at unit price per connection made in accordance with Specifications and located as indicated on Plans. This includes tapping sleeve, valve, valve box, and any other items required to perform the connection. Valves used in performing wet taps are not eligible for separate pay and will be included in the price per wet tap.
- N. Rock Excavation: Paid for per cubic yard as determined by the Engineer in the field and shall be considered to be of the type requiring blasting or jack hammering.
- O. Underground Marking Tape: No separate payment will be made for marking tape.
- P. Tracer wire: No separate payment will be made for tracer wire installation.

END OF SECTION 33 10 00

SECTION 33 21 00 - SEPARATION OF PIPED UTILITIES

PART 1 - GENERAL

1.1 REQUIREMENTS INCLUDED

- A. Location of piped utilities to separate water mains from sewer facilities

1.2 RELATED WORK

- A. Appropriate Piped Utility Sections

PART 2 - PRODUCTS

N/A

PART 3 - EXECUTION

3.1 PARALLEL INSTALLATION

- A. Separate water mains at least ten (10)-feet horizontally, measured edge to edge, from any sewer facility whenever possible.
- B. When local conditions prevent a horizontal separation of ten (10)-feet, closer installations may be made if:
 - C. The bottom of the water main is at least eighteen (18)-inches above the top of the sewer facility; or
 - D. The sewer is constructed of materials equivalent to water main standards and pressure tested to assure water tightness prior to backfilling.

3.2 CROSSINGS

- A. Separate water mains crossing sewer facilities by at least eighteen (18)-inches between the bottom of the water main and the top of the sewer facility whenever possible.
- B. When local conditions prevent a vertical separation as described above, the following construction shall be used:
 - 1. Sewers passing over or under water mains should be constructed of materials equivalent to water main standards and pressure tested to assure water tightness prior to backfilling.

2. Water mains passing under sewers shall, in addition, be protected by providing:
 - a. A vertical separation of at least eighteen (18)-inches between the bottom of the sewer and the top of the water main.
 - b. Adequate structural support for the sewer to prevent excessive deflection of joints and settling on and breaking the water mains.
 - c. That the length of water pipe be centered at the point of crossing so that the joints will be equidistant and as far as possible from the sewer.

3.3 SEWER FACILITIES

- A. Do not install water mains or sewer facilities which pass through or contact each other.

END OF SECTION 33 21 00

**ATTACHMENT I
SERVICE LINE
REPLACEMENT DETAIL**

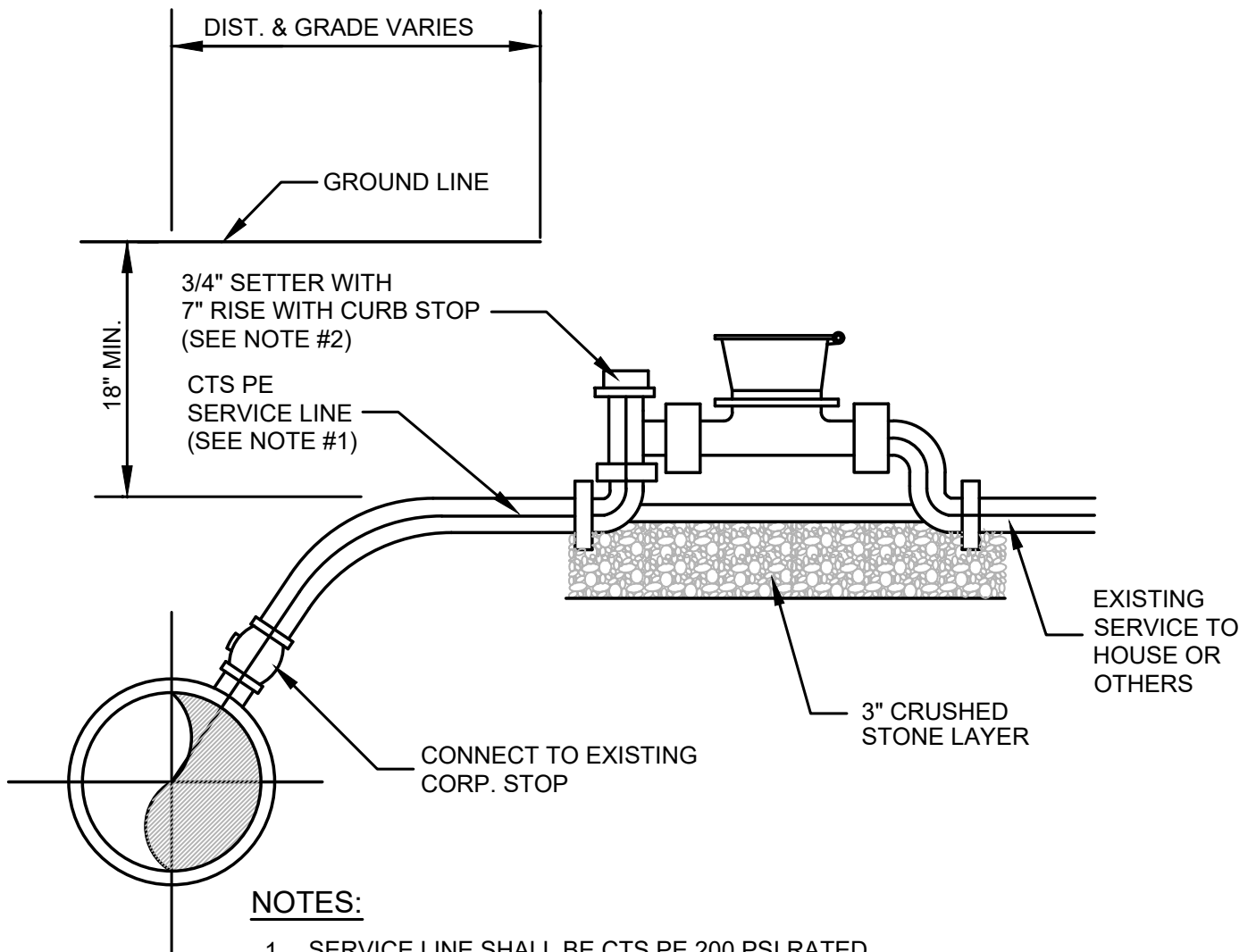

NOTES:

1. SERVICE LINE SHALL BE CTS PE 200 PSI RATED. INSERT STIFFENERS SHALL BE USED AT ALL CONNECTIONS.
2. COPPER METER SETTER SHALL BE FORD V272-7W-NL OR APPROVED EQUIVALENT.

**ATTACHMENT II
SERVICE LINE MAP**

Legend



400 ft

3/4 Water Service Line

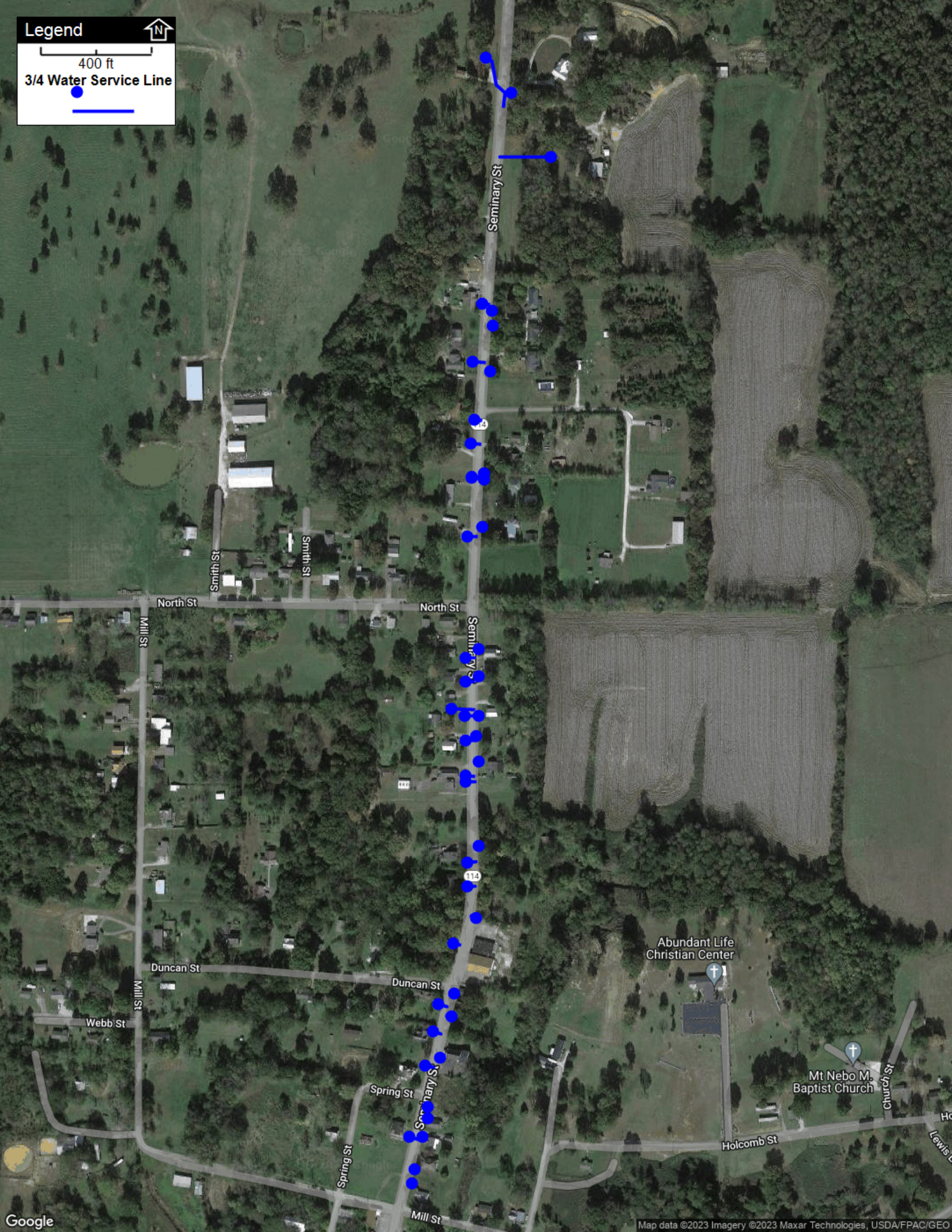

Seminary St

North St

North St

Duncan St

Duncan St

Webb St

Spring St

Spring St

Holcomb St

Mill St

Abundant Life Christian Center

Mt Nebo M. Baptist Church