



**STATE OF TENNESSEE
DEPARTMENT OF TRANSPORTATION**

ROADWAY DESIGN DIVISION
SUITE 1200 JAMES K. POLK BUILDING
505 DEADERICK STREET
NASHVILLE, TENNESSEE 37243-3848
(615) 741-2221

JOHN C. SCHROER
COMMISSIONER

BILL HASLAM
GOVERNOR

INSTRUCTIONAL BULLETIN NO. 18-07

Regarding New Section 9 - Multimodal Design

Effective immediately, a new Section 9 – Multimodal Design is added to the Roadway Design Guidelines. The purpose of this new section is to provide additional guidance for the multimodal design process. These new design guidelines shall be used on all new start projects and considered for current projects that have not been submitted for Right-of-Way Field Review. Section 9 – Multimodal Design document is available at the link below.

https://www.tn.gov/content/dam/tn/tdot/roadway-design/documents/design_guidelines/DG-S9.pdf.

This new section requires updates to previous sections in the Roadway Design Guidelines. Section 3-310.05 – Curb Ramps, has been deleted. The information contained in this section is now part of the new Section 9.

A new Multimodal Deviation Request Form has been created. This form is to be used when the multimodal standard criteria cannot be met and modifications are required.

With this new section 9, three new standard drawings have been created. MM-TS-1, **Bike Accommodation Design Guidance** and MM-TS-2, **Pedestrian Facility Design Guidance** have been developed to provide guidance to designers on how to accommodate bicycle and/or pedestrians on existing facilities during 3R projects. RD11-TS-8, **Shared Use Path Typical Sections** standard drawing voids RD01-TS-8 and reduces the minimum shared use path width from 12' to 10' and added some pavement design guidance and minimum geometric design criteria.

Standard Drawings:

<u>DRAWING NUMBER</u>	<u>REVISION DATE</u>	<u>DESCRIPTION</u>
MM-TS-1	n/a	Bike Accommodation Design Guidance
MM-TS-2	n/a	Pedestrian Facility Design Guidance
RD11-TS-8	n/a	Shared Use Path Typical Sections

Roadway Design Guidelines Chapter 5 – Index of Standard Drawings has been updated.

The TDOT Multimodal Division has released the new Multimodal Project Scoping Manual to provide guidance on project planning. The document is available at Design Division web page under Reference documents.

Attached to this bulletin is the updated RDG Sections, the new Multimodal deviation request form, and new/revised standard drawings.

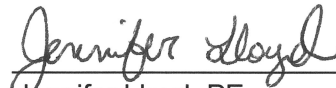

Jennifer Lloyd, PE
Civil Engineering Director
Roadway Design Division

KJL:ARH:RB:ADP:SSH
April 26, 2018

1-200.12 PEDESTRIAN ACCESSIBILITY AND BICYCLE ACCOMMODATION DURING RESURFACING PROJECTS

During resurfacing projects, it is the Department's commitment to identify and correct existing curb ramp installations to meet the geometric requirements shown on Public Rights-of-Ways Accessibility Guidelines (PROWAG). See TDOT Policy Number 530-01 for additional information. Designers should refer to Section 9, Multimodal design, of the Roadway Design Guidelines and the RP-H series roadway standard drawings for guidance regarding geometric design requirements of curb ramps. Existing pedestrian and/or bicycle facilities shall be evaluated for safety, connectivity, ADA accessibility, signalization, proper signage etc. as well as possible improvements during the project PS&E. All deficiencies shall be documented for roadway designer to address during the project development.

1-200.35 LOCAL PROGRAM DEVELOPMENT PROJECTS

The Local Programs Development Office assists local governments with administering state and federal aid projects such as roadway resurfacing, greenways, signalization of intersections, and bridge replacements. These projects must follow the Local Government Guidelines Manual. All projects developed under the Local Program which involve a roadway shall be designed in accordance to TDOT Design Policies and Procedures, and Federal Regulations. Locally Managed Projects may be located on the National Highway System, State Routes, or Local Routes. In addition, the funding for each Locally Managed Project may come from Federal-aid and/or State Funds combined with Local Funds, or solely from Federal-aid, State Funds, or Local Funds. Projects to be designed under the local program are primarily on local roads. In general, they should not involve the state highway system, the national highway system or the interstate system.

A TDOT Design Manager will manage all projects on the NHS System, other projects as well may be assigned a manager to provide full oversight. The TDOT Design Manager is responsible for ensuring all TDOT Design Policies and Procedures have followed. The TDOT Design Manager is not responsible for providing guidance or assistance in the actual design of the project. A "Design Certification Letter" will be required for all roadway projects. Any comments provided by the Department shall be incorporated into the design of the project.

Projects such as Bridge Replacement (BRZ) Projects, State Industrial Access (SIA), Local Interstate Connector (LCI), Intersection Improvements, Roadway Resurfacing, Roadway features or Auxiliary to Roadway Features, Roadway Signing and Striping Improvements are considered a roadway project, as well as improving and/or adding new Pedestrian Facilities, Bike Lanes or Routes, Shared-use Paths, Safe Routes to Schools, and Landscape Projects if the project scope would involve any part of a roadway (including clear zone) and/or TDOT ROW. All controlling elements of roadway geometric design should be considered during development of such projects. For further information refer to Section 9.

Projects such as Building Projects, Parking Improvements do not involve any part of roadway considered a non-roadway project and they are covered under The Local Government Guidelines (LGG) Manual-Chapter 10: Non- Traditional Projects.

Refer to *Local Program Guidelines*, Chapter 5, "Roadway Design Procedures, Including Structural Design" for more information.

2-300.10 GUIDELINES FOR CONSTRUCTION AND RESURFACING OF PUBLIC ROAD INTERSECTIONS AND DRIVEWAYS ON HIGHWAY PROJECTS

I. GENERAL

For new construction projects, new public road intersections and new driveway entrances shall be located and designed in accordance to the TDOT *Manual for Constructing Driveway Entrances on State Highways (2015 Edition)* and to the current RP-D series standard drawings. For retrofit, resurfacing, and reconstruction projects; the designer should leave existing public road intersections and existing driveway entrances in place if the existing locations do not affect operational safety. It is important to identify potential conflicts during PS&E and have Traffic Operations Division evaluate the potential conflicts because driveway entrance relocations will affect R.O.W. acquisition.

II. DEFINITION OF TERMS

Paved Shoulder Width - The width of the shoulder paved as part of the project.

Paver Width - The width of asphalt paving machine used on mainline paving with maximum width not to exceed 12 feet or to extend beyond right-of-way limit.

Normal Right-of-Way - An imaginary line which, when projected through a public road intersection, would enclose the normal slopes of the highway.

III. RESURFACING

- A. Where directed by the TDOT Engineer, the Contractor shall be required to shape public side roads, business entrances, and private drives, as well as clean existing drains before placing materials. All costs are to be included in the price bid for other items of construction.
- B. Resurfacing projects on roadways with shoulders and ditches (no curb or gutter):
 1. All public side roads shall be paved one paver width through the intersection as a minimum. A satisfactory transition from the new pavement to the existing grade of the intersecting public road or business entrance shall be provided. Should the pavement of the intersecting public road be distressed, the resurfacing width may be increased to the normal right-of-way line.
 2. Private driveways, field entrances, and business entrances will be resurfaced a paver width (lane width) as a minimum. A pavement taper to transition the new pavement shall be required, it shall be based on an additional 1 foot of width per inch depth of pavement. If the shoulder is narrow enough that the sum of the shoulder and the transition are less than a paver width (lane width), the transition shall occur within the paver width. If the sum of the shoulder and the transition is greater than a paver width (lane width), the transition shall occur outside of the paver width.

- C. Resurfacing projects on roadway with urban curb and gutters
 - 1. Public road intersections shall be resurfaced to the end of the radius. A satisfactory transition from the new pavement to the existing grade of the intersecting public road shall be provided.
 - 2. Residential driveways and business entrances shall have a minimum width of material not less than one foot used in the transition to feather the pavement edge.
- D. In all cases, the length of the pavement transition, the thickness and width of the resurfacing and any additional pavement materials shall be as directed by the TDOT Engineer.

IV. NEW OR RECONSTRUCTION

- A. Facilities with Full Access Control
 - 1. Full access control will be maintained for the entire designated project limits.
- B. Facilities with Limited Access Control
 - 1. Access will be allowed at public roads and streets only. No driveways will be permitted access to the mainline project.
- C. Facilities with Partial Access Control - driveways permitted:
 - 1. Fence Opening:

One 50-foot opening in the control access fence will be provided per tract remainder, unless access is provided from an intersecting road or based on physical conditions and/or conflicts with other design considerations, which prevent an access opening.
 - 2. Existing Driveways:

Existing paved driveway per tract remainder will be replaced in-kind to a touchdown point.

Where the existing driveway is unpaved and the proposed driveway exceeds 7 percent in grade, each proposed driveway will be paved to a touchdown point or until the grade is less than 7 percent.

Where the existing driveway is unpaved and the proposed driveway is less than 7 percent in grade, each proposed driveway will be paved a shoulder width from the edge of pavement and the remainder of that driveway replaced in-kind to a touchdown point.

3. Requirements for field entrances and/or other driveways:
New driveways provided in the plans will be paved based on the 7 percent criteria. Those 7 percent or steeper in grade will be paved and those flatter than 7 percent will be covered with base stone.

Field entrances provided in the plans will be covered with base stone.

Normally, one field entrance or driveway, whichever is appropriate, per tract remainder will be provided except in the following circumstances:

- a. In the project's preconstruction condition, there is a barrier to access such as a substantial cut, fill, ditch or curb.
- b. A non-gated fence where the existing frontage is totally fenced.
- c. In the project's post-construction condition, there is a substantial cut, fill, or ditch.

Also, small remainders and damage considerations are to be reviewed by the Roadway Design Division and the Right-of-Way Office to determine if a proposed driveway or field entrance is justified. The location, design and method of surfacing of the field entrance or driveway must be in accordance with the previously mentioned Rules. If the landowner does not desire a driveway, then it will not be included in the project.

4. All public roads will be paved to a touchdown point.

D. Non-Access Control Facilities

1. Existing paved driveways will be replaced in-kind to a touchdown point.
2. Where the existing driveway is unpaved and the proposed driveway exceeds 7 percent in grade, each proposed driveway will be paved to a touchdown point or until the grade is less than 7 percent.
3. Where the existing driveway is unpaved and the proposed driveway is less than 7 percent in grade, each proposed driveway will be paved a shoulder width from the edge of pavement and the remainder of that driveway replaced in-kind to a touchdown point.

4. Requirements for field entrances and/or other driveways:

New driveways provided in the plans will be paved based on the 7 percent criteria. Those 7 percent or steeper in grade will be paved and those flatter than 7 percent will be covered with base stone.

Field entrances provided in the plans will be covered with base stone.

Normally, one field entrance or driveway, whichever is appropriate, per tract remainder will be provided except in the following circumstances:

- a. In the project's preconstruction condition, there is a barrier to access such as a substantial cut, fill, ditch or curb.
- b. A non-gated fence where the existing frontage is totally fenced.
- c. In the project's post construction condition, there is a substantial cut, fill, or ditch.

Also, small remainders and damage considerations are to be reviewed by the Roadway Design Division and Right-of-Way Office to determine if a proposed driveway or field entrance is justified. The location, design and method of surfacing of the field entrance or driveway must be in accordance with the previously mentioned Rules. Variances may be permitted due to the proximity of existing drives to property lines. No drives will be allowed in radii. If the landowner does not desire a driveway, then it will not be included in the project.

5. All public roads will be paved to a touchdown point.

The department is responsible to maintain, upgrade or correct all pedestrian facilities to meet Public Rights-of-Ways Accessibility Guidelines PROWAG during the resurfacing projects. See TDOT Policy Number 530-01 for additional information. The local government is responsible for maintaining beyond curb face (sidewalks, grass strips, curb ramps, etc.) after the construction.

2-440.00 PEDESTRIAN, BICYCLE, AND ADA CONSIDERATIONS FOR ROUNDABOUTS

The number of pedestrian/vehicle conflict points is reduced when a roundabout is used for intersection control. Since a roundabout may not have pedestrian signal phases or pedestrian push-buttons, and does not require vehicles to make a complete stop, other measures should be designed to ensure drivers and pedestrians are clearly able to see each other. Proper design should produce conditions needed to allow vehicles to yield to the pedestrians and at a reduced speed.

Since a goal of any roundabout is to reduce speeds without actually stopping the vehicles, a properly designed roundabout will reduce the risk of pedestrian/vehicle collisions due to the slow speeds expected. There are design elements that may be beneficial to pedestrian

safety when designing the crosswalks at a roundabout. The following general design criteria should be considered for crosswalks at roundabouts:

- Minimized crossing distance to reduce pedestrian exposure to traffic.
- Where possible, crosswalks should be designed to provide pedestrians a straight walking path across the traffic lanes (90 degrees to traffic flow preferred), including any right-turn bypass lanes. This may not apply to small single lane approaches where a straight crossing route can be provided regardless of splitter island or roadway deflection.
- To minimize out-of-direction travel for pedestrians, crosswalks should be located as close as possible to the intersection while still maintaining required queue space for vehicles. A mid-block pedestrian crossing near a roundabout is not recommended.
- At single lane roundabouts, crosswalks should typically be located one vehicle length (approximately 20 feet minimum) behind the yield line; this gives the driver at the yield line the ability to concentrate on entering the roundabout.
- For multi-lane roundabouts crosswalks may be located one vehicle length behind the yield line. A designer may need to “bend” crosswalk alignments at the splitter island, where necessary to provide 90 degree crossings at the entrance/exit lanes where possible.
- Splitter islands should be a minimum width of 6 feet at the narrow end of the island – 9.5 feet preferred. The refuge area (gap) within the splitter island should be 10’ long. Therefore the minimum dimensions for the refuge area should be 6’ x 10’. See the standard drawings.
- The finished grade of the pedestrian crossing (refuge) areas within the splitter islands should be at or slightly above the elevation of the adjacent pavement. The designer should avoid elevating the refuge area except the minimal amount needed for proper drainage.

Additional details for crosswalks can be found on the standard drawings. The standard drawings for **curb** ramps provide details for ramps at the exterior curb cuts for crosswalks. The splitter island refuge area should be wide enough to accommodate multiple modes of pedestrian traffic including side-by-side wheelchairs, bicycles with trailers, pedestrians, and pedestrians with baby strollers.

Accommodating designs for visually impaired and disabled pedestrians should be a priority at roundabouts since those pedestrians tend to rely on audio signals more than other pedestrians. Roundabouts generally do not require audio devices for pedestrian crossings, but in special cases they may be needed at a roundabout. In addition, detectable warning surfaces should be provided at all paths, including the splitter island refuge area, leading to any traffic lane. The Roadway Design Division’s **curb** ramp standard drawings and roundabout standard drawings provide detectable warning surface details. All pedestrian facilities should be designed to comply with the latest version of **PROWAG**. See **Section 9 – Multimodal Design** section for additional information.

The TDOT bicycle and pedestrian policy requires consideration be given to providing provisions for bicycles to be integrated into new construction and reconstruction of roadway projects through design features appropriate for the context and function of the transportation facility.

Bicyclists should be given a choice when approaching a roundabout of either going through the roundabout and mixing with the vehicles in the circulatory stream, or exiting the

roadway prior to entering the roundabout and continuing around the roundabout on a shared-use path (sidewalk) with pedestrians. To optimize safety and the most efficient operation of the roundabout, bicyclists should be provided with shared-use paths around the perimeter of the roundabout. For the purposes of most TDOT design projects, the designer should provide bike ramps for exiting the roadway to the shared use path, and then ramps for re-entering the roadway, bicycle lane, or roadway shoulder on the opposite side of the roundabout.

The bicycle exit ramp (the ramp the bicyclist uses to exit the roadway prior to the roundabout) should be provided prior to the pedestrian crossing or at least 100' prior to the yield line, whichever of the two is greater. At the exits, a bicycle entrance ramp should be provided after a pedestrian crosswalk or 100' from the exit, whichever is greater.

Bicycle ramps should be a minimum 6' wide between the roadway and the shared-use path. This width will be large enough to accommodate a bicycle pulling a child cart, but small enough to prevent a vehicle from using it. The bicycle exit and entrance ramp should typically be placed at a 20 to 45 degree departure angle from the roadway. A perpendicular bicycle ramp is not recommended since it would require a bicyclist to stop their forward momentum as they exit (or enter) the roadway. See the standard drawings for details of bicycle entrance and exit ramps.

Where cyclists prefer to pass through the roundabout, the designer should treat them as a vehicle in the circulating stream. Any designated bike lanes on the approach to the roundabout should be terminated a minimum of 100 feet upstream of the yield line. This will allow the bicycle to mix with the traffic, both in lane position and speed. Specific pavement markings for bicycles should not be present within the circulatory roadway.

If the roundabout is being designed at a location where there is a designated shared-use path, the design should include those geometric features detailed on standard drawing RD-TS-8. To minimize confusion between bicycle ramps and pedestrian ramps, detectable warning surfaces should be placed at the top of the bicycle ramps rather than at the bottom as is the practice with pedestrian ramps. At rural and urban locations where current pedestrian and bicycle traffic is not significant, but expected to increase, the designer should include measures in the plans to accommodate future needs or demands. These may include:

- Rough grading the perimeter of the roundabout to accommodate future sidewalks, landscaping buffer strip, shared use paths, etc...
- Installing **curb** ramps or lowered curb at logical "future" locations along perimeter curbing
- Providing cut-throughs (gaps) at the splitter islands for future crosswalks
- Obtaining adequate right-of-way to accommodate future measures including lighting

Additionally, the designer should refer to the AASHTO Guide for the Development of Bicycle Facilities, **2012**.

3-310.05 CURB RAMPS

This section has been removed and incorporated into Section 9 – Multimodal Design

3-310.10 DRIVEWAY APRONS

Right-of-Way plans for new construction or reconstruction projects shall accommodate the appropriate driveway aprons. The driveway standard drawings have been modified to provide **PROWAG** compliant cross-slope for sidewalks through driveway aprons. The aprons have also been modified to provide for a better turning radius into the drive.

4-411.04 RUMBLE STRIPES

Rumble stripes are a traffic warning device, and when required, shall be constructed in accordance with Standard Drawing T-M-16. A scored rumble stripe is a scored rumble placed along the outside edge line of the travel lane.

Refer to Section 4-716.15 for guidelines for the placement of rumble stripes. Rumble stripes should normally only be placed on rural routes with posted speeds of 45 mph or greater. The rumble stripe shall consist of a 60 foot scored rumble followed by a 15 gap to allow for bicycles to cross without having to traverse the rumble. Rumble stripes may be used on urban routes where accident history or other factors warrant the placement. When placed on urban routes, designers should give consideration to expected bicycle traffic and noise generated.

Scored rumble stripes are to be paid for under Item No. 411-12.03, Scoring for Rumble Stripe (Non-Continuous) (8 inch Width), L.M. or Item No. 411-12.04, Scoring for Rumble Stripe (Non-Continuous (4 inch Width), L.M. The item will be measured and paid as the actual length of pavement scored along each shoulder.

When rumble stripes are specified, pavement markings shall be Spray Thermoplastic (60 mil). Enhanced Flatline Thermoplastic Markings shall not be used. Striping is to be paid for under the appropriate pavement marking item number.

Multimodal Design Deviation Request Form

This form shall be completed when deviations are requested from the minimum design standards related to multimodal facilities. The minimum design standards are typically found in Chapter IX of the TDOT Design Guidelines and TDOT’s Standard Drawings. Designing a multimodal facility/roadway is not a one-size-fits-all approach. It requires an analysis of various site conditions to determine appropriate treatments and solutions. Using standard design elements, criteria, and dimensions may not be possible in these contexts that are often in constrained right-of-way. Applying flexibility in the geometric design process is often justified.

Project Data:

PIN:				
County:				
Federal Project No.:				
State Project No.:				
Facility Type:	Roadway <input type="checkbox"/>	Pedestrian <input type="checkbox"/>	Bicycle <input type="checkbox"/>	Shared-Use <input type="checkbox"/>
Local Program Project:	Yes <input type="checkbox"/>	No <input type="checkbox"/>		

Roadway Data (route adjacent to or associated with the multimodal feature):

Route:			
Project Limits:			
ADT:			
Design Speed:			
Posted Speed:			
Functional Class:	Arterial <input type="checkbox"/>	Collector <input type="checkbox"/>	Local <input type="checkbox"/>
Access Control:	None <input type="checkbox"/>	Partial <input type="checkbox"/>	Full <input type="checkbox"/>

Project Type:

New Alignment	<input type="checkbox"/>	Road Diet	<input type="checkbox"/>
Reconstruction	<input type="checkbox"/>	Signalization	<input type="checkbox"/>
Rehabilitation (3R)	<input type="checkbox"/>	Road Safety Audit	<input type="checkbox"/>
Other maintenance	<input type="checkbox"/>	Other:	

Seeking Design Deviation related to (check all that apply):

- | | | | |
|------------------------------|--------------------------|-----------------------------|--------------------------|
| Vehicular lane dimension | <input type="checkbox"/> | Shared-use path | <input type="checkbox"/> |
| Horizontal or vertical curve | <input type="checkbox"/> | Mid-block crossing | <input type="checkbox"/> |
| Sight distance | <input type="checkbox"/> | RRFB or HAWK | <input type="checkbox"/> |
| Shoulder width | <input type="checkbox"/> | Bike lane | <input type="checkbox"/> |
| Pavement markings | <input type="checkbox"/> | Bike lane buffer | <input type="checkbox"/> |
| Signs | <input type="checkbox"/> | Bike route | <input type="checkbox"/> |
| Signalization | <input type="checkbox"/> | Bike lane at intersection | <input type="checkbox"/> |
| Roadside safety hardware | <input type="checkbox"/> | Two-way separated bike lane | <input type="checkbox"/> |
| Curb shape | <input type="checkbox"/> | Transit facility/stop | <input type="checkbox"/> |
| Curb ramp | <input type="checkbox"/> | Other: | |
| Sidewalk | <input type="checkbox"/> | | |

Design Deviation request is justified based on guidance from the following:

Design Guidance Source	Design Guidance Met?				Source Reference if answered "Yes" (page, section, drawing, etc.)
	Yes	No	N/A	Don't Know	
AASHTO	<input type="checkbox"/>	<input type="checkbox"/>	<input type="checkbox"/>	<input type="checkbox"/>	
PROWAG ¹	<input type="checkbox"/>	<input type="checkbox"/>	<input type="checkbox"/>	<input type="checkbox"/>	
NACTO	<input type="checkbox"/>	<input type="checkbox"/>	<input type="checkbox"/>	<input type="checkbox"/>	
FHWA	<input type="checkbox"/>	<input type="checkbox"/>	<input type="checkbox"/>	<input type="checkbox"/>	
NCHRP	<input type="checkbox"/>	<input type="checkbox"/>	<input type="checkbox"/>	<input type="checkbox"/>	
TDOT Design Guidelines (Section IX)	<input type="checkbox"/>	<input type="checkbox"/>	<input type="checkbox"/>	<input type="checkbox"/>	
TDOT Standard Drawings	<input type="checkbox"/>	<input type="checkbox"/>	<input type="checkbox"/>	<input type="checkbox"/>	
Guidance from other states	<input type="checkbox"/>	<input type="checkbox"/>	<input type="checkbox"/>	<input type="checkbox"/>	

1. Proposed Right-of-Way Accessibility Guidelines, i.e. United States Access Board's *Proposed Guidelines for Pedestrian Facilities in the Public Right-of-Way*.

In the space provided, please provide an explanation of the requested design deviation and describe other nationally recognized guidance that is met and that the design is based upon. Attach documentation of the specific design guidance met.

In the space provided, considering the safety and capacity of the facility, describe why the recommended deviation is the best design solution given the conditions, constraints, and particulars of this situation.

Local Program Projects require an acceptance letter from the highest city official or city engineer. The letter shall be attached to this request form.

Submitted by:

Name:

Date:

Division/Firm:

Title:

Signature: _____

Approved by: _____

Signature: _____

TDOT Roadway Design Division

09-APR-2018 09:05 \\ag03scdw\00010\projects\Standard Drawings\Working Folder for Eugene\Draft\1 ROADWAY DESIGN STANDARDS\2 TYPICAL SECTIONS AND DESIGN CRITERIA\RD11TS8-2018XXXX.dgn

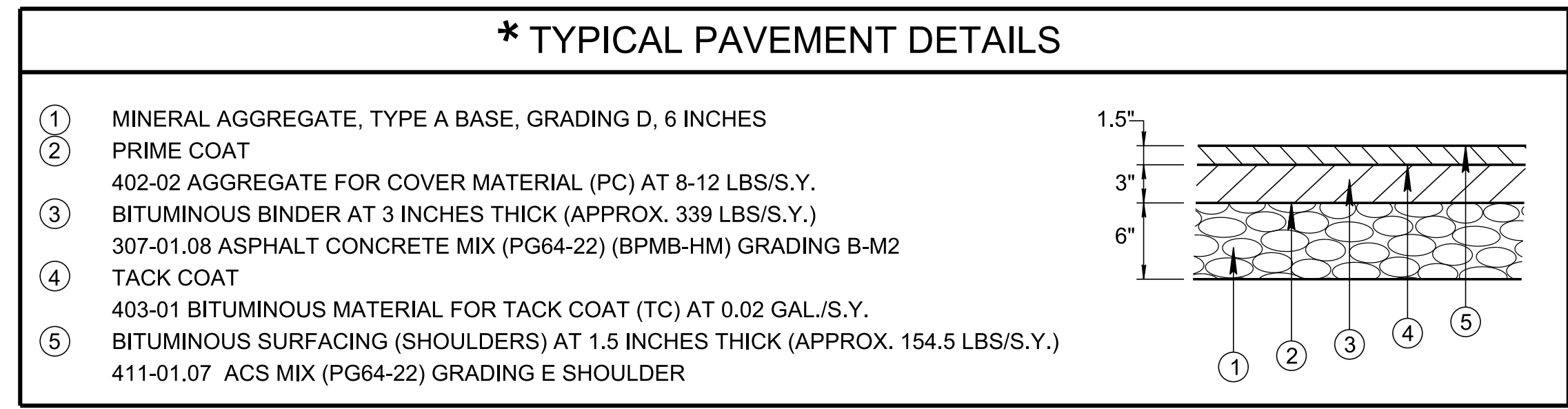
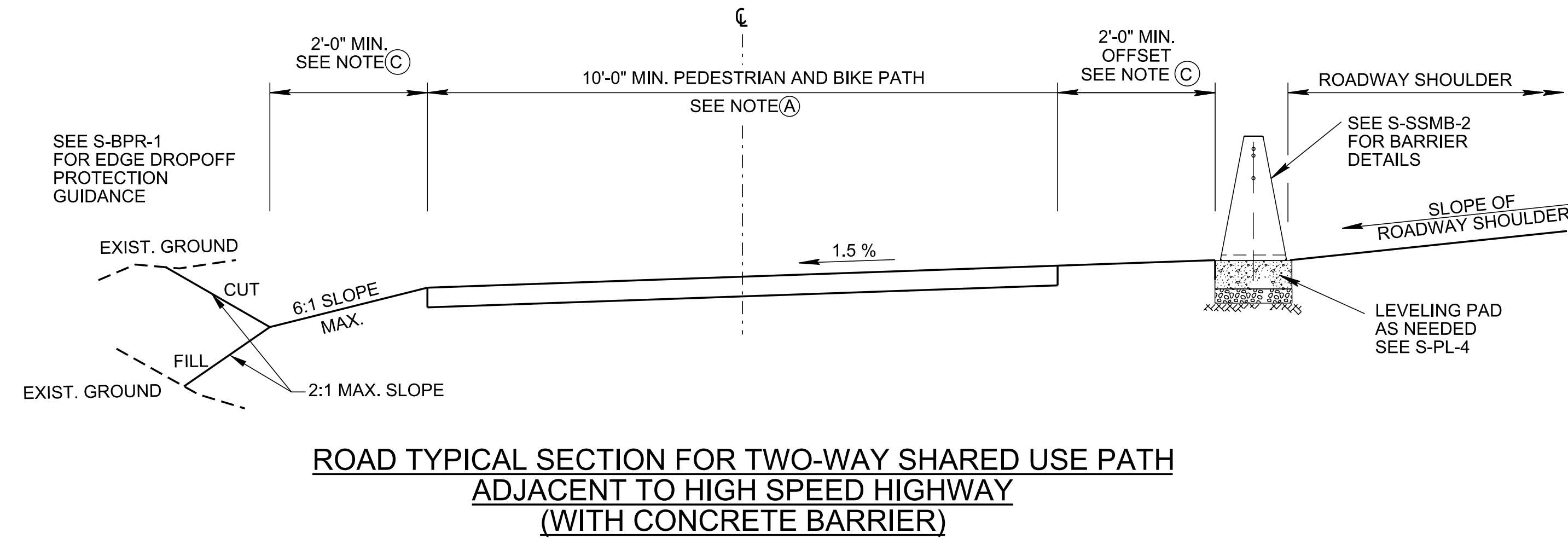
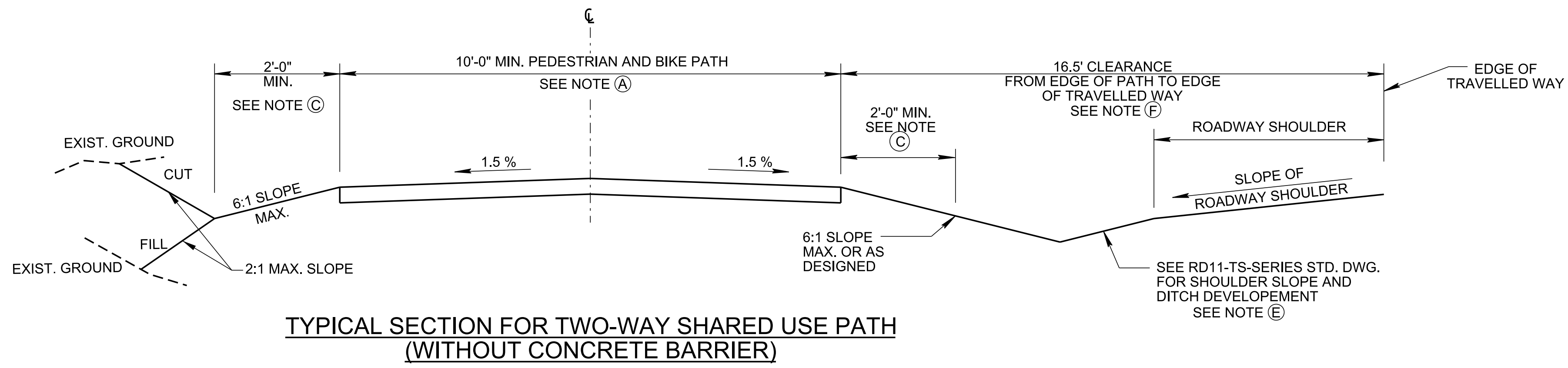

* TYPICAL PAVEMENT DETAILS ARE PROVIDED FOR GUIDANCE. ALTERNATIVE PAVEMENT DESIGN OR MATERIAL MAY BE USED AND SHOWN ON THE PLANS.

GEOMETRIC DESIGN CRITERIA	
①	18 MPH BICYCLE DESIGN SPEED
②	PEDESTRIAN DENSITY 200 PED/HR
③	HORIZONTAL CURVE 60' MIN. RADIUS
④	VERTICAL GRADE 5% MAX.
⑤	MINIMUM PAVED PATH WIDTH 10' WITH MAX. 6:1 SLOPE, 2' WIDE, CLEAR OF OBSTRUCTIONS
⑥	MAXIMUM CROSS SLOPE 2%

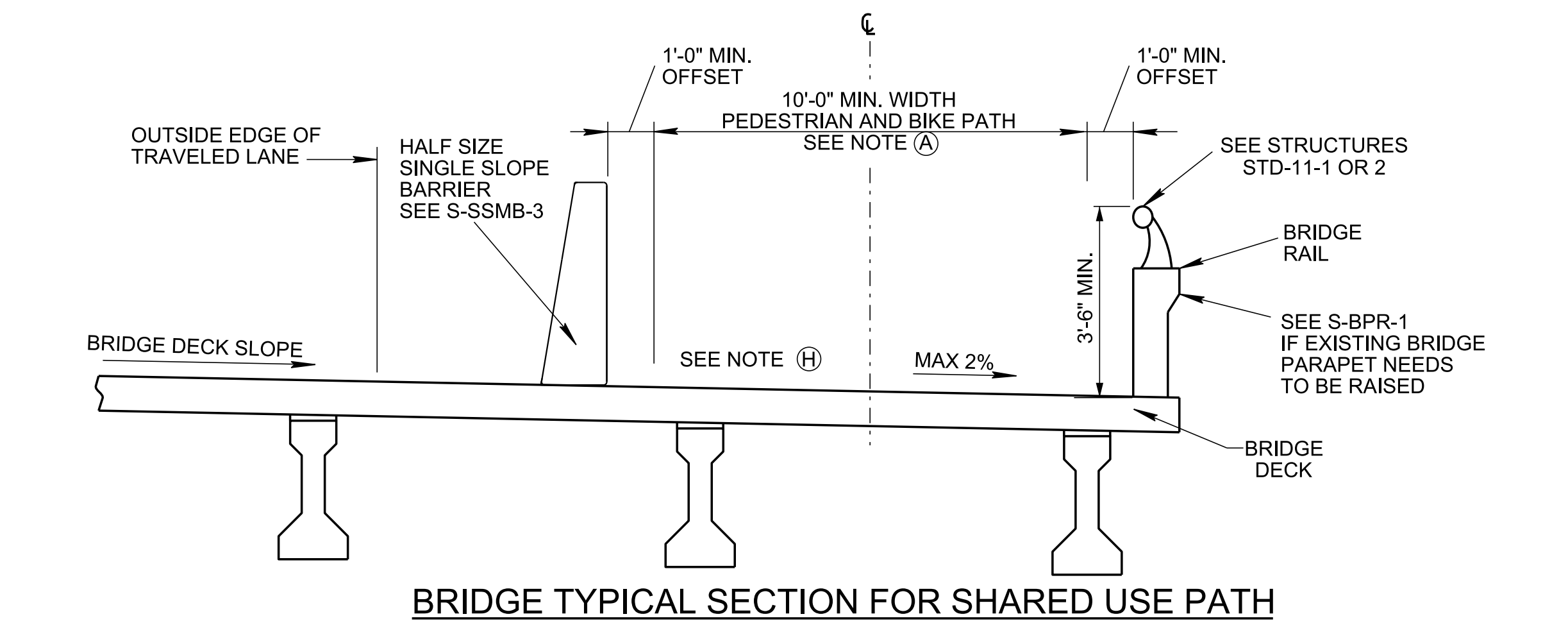
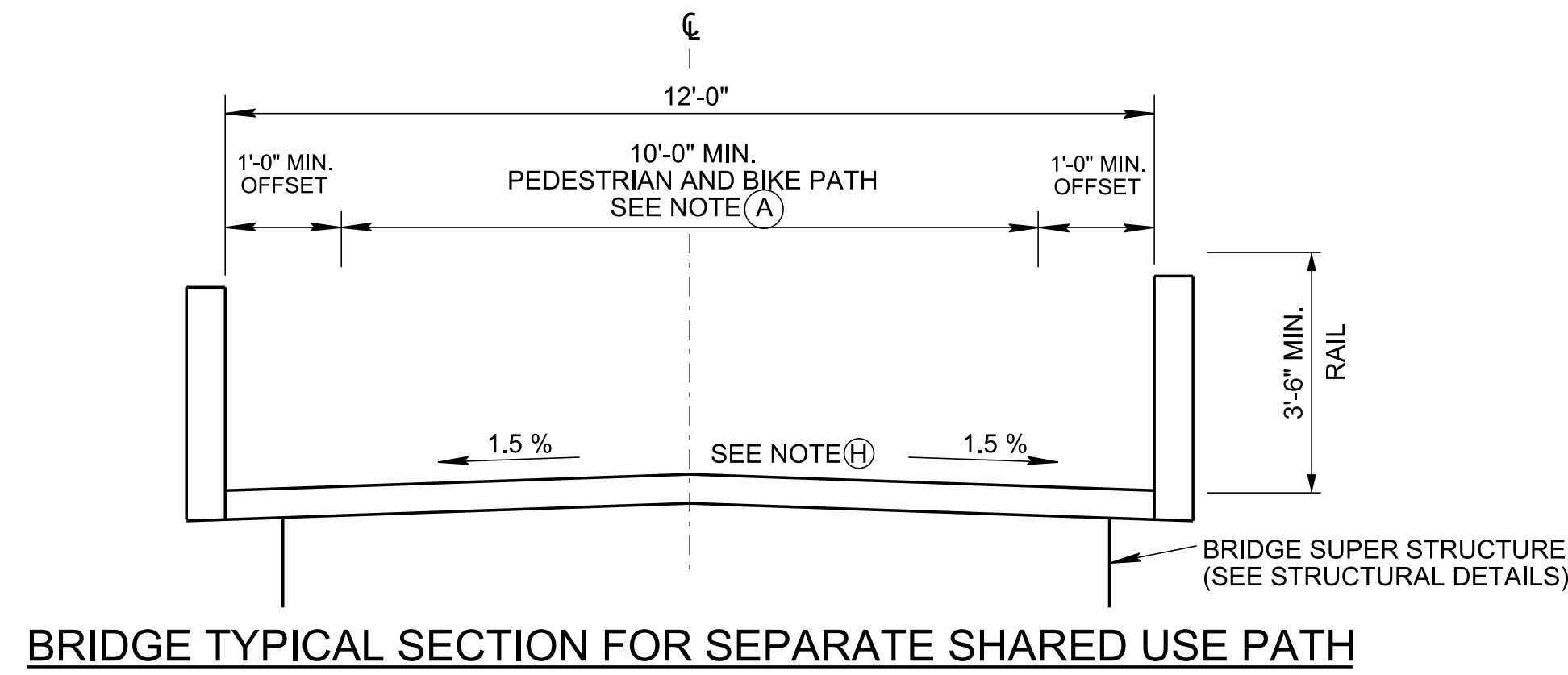

DESIGN NOTES	
(A)	UNDER CERTAIN CONDITIONS IT MAY BE NECESSARY OR DESIRABLE TO USE ALTERNATIVE PATH WIDTHS. TDOT STANDARDS ARE BASED ON 200 - 300 USERS PER HOUR, A LEVEL OF SERVICE (LOS) OF "C". REFER TO THE HIGHWAY CAPACITY MANUAL -6TH EDITION FOR MORE INFORMATION.
(B)	THE MINIMUM WIDTH OF A ONE -DIRECTIONAL SHARED USE PATH IS 6 FEET.
(C)	2 FEET ON A 6:1 SLOPE IS DESIRABLE TO PROVIDE LATERAL OFFSET FROM TREES, POLES, WALLS, FENCES, GUARDRAILS, OR OTHER LATERAL OBSTRUCTIONS. WHERE THE PATH IS ADJACENT TO CANALS, DITCHES OR SLOPES STEEPER THAN 3:1, A WIDER SEPARATION SHOULD BE CONSIDERED.
(D)	THE VERTICAL CLEARANCE TO OBSTRUCTIONS SHOULD BE A MINIMUM OF 8 FEET. HOWEVER, VERTICAL CLEARANCE MAY NEED TO BE GREATER TO PERMIT PASSAGE OF MAINTENANCE AND EMERGENCY VEHICLES. IN UNDER CROSSINGS AND TUNNELS, 10 FEET IS DESIRABLE FOR ADEQUATE VERTICAL SHY DISTANCE.
(E)	A DRAINAGE OR STORMWATER CONVEYANCE SYSTEM DITCH SHOULD BE LOCATED PROPERLY BETWEEN THE SHARED USE PATH AND ROADWAY TO ENSURE THAT WATER DOES NOT FLOW ONTO THE ROADWAY OR SHOULDER. ALSO, DITCH SHOULD BE SUFFICIENT ENOUGH TO REMOVE THE ADDITIONAL RUNOFF.
(F)	WHEN THE DISTANCE BETWEEN THE EDGE OF TRAVEL LANE AND THE SHARED USE PATH IS LESS THAN 16.5 FEET ON A FACILITY WITH DESIGN SPEED OF 45 MILES PER HOUR, A BARRIER RAIL IS REQUIRED. (THIS REDUCED WIDTH SHALL MEET THE REQUIREMENTS FOR OCCASIONAL MAINTENANCE ACTIVITIES.)
(G)	CLEAR ZONE SHOULD BE MAINTAINED BETWEEN THE ROADWAY AND THE SHARED USE PATH. IF CLEAR ZONE CAN NOT BE ACHIEVED, AN APPROPRIATE BARRIER SHOULD BE CONSIDERED FOR SPEED MORE THAN 45 MPH.
(H)	ON ALL BRIDGE DECKS, SPECIAL CARE SHALL BE TAKEN TO ENSURE THAT BICYCLE- SAFE EXPANSION JOINTS ARE USED AND DECKING MATERIALS THAT MAY BECOME SLIPPERY WHEN WET ARE AVOIDED.
(I)	SEE STANDARD DRAWINGS T-M-10, T-M-11, T-M-12, AND T-M-13 FOR SIGNING AND PAVEMENT MARKINGS.
(J)	THE PURPOSE OF THIS STANDARD IS TO PROVIDE MINIMUM GEOMETRIC AND SAFETY DESIGN STANDARDS DURING THE DEVELOPMENT OF NON-MOTORIZED TRANSPORTATION FACILITIES. ALL FACILITIES SHALL BE DESIGNED FOR ADA ACCESSIBILITY.
(K)	FOR FURTHER INFORMATION, REFER TO AASHTO "GUIDE FOR THE DEVELOPMENT OF BICYCLE FACILITIES" FOR GEOMETRIC DESIGN REQUIREMENTS AND TDOT ROADWAY DESIGN GUIDELINES MULTI-MODAL DESIGN GUIDE SECTION.
(L)	SHARED USE PATHS DO NOT REQUIRE PAVEMENT MARKINGS, HOWEVER, PROPER SIGNAGE MUST BE INSTALLED PER STANDARDS AND THE CURRENT EDITION OF THE MANUAL ON UNIFORM TRAFFIC CONTROL DEVICES (MUTCD).

PEDESTRIAN FACILITY SAFETY GUIDE

LATERAL SEPARATION OPTIONS

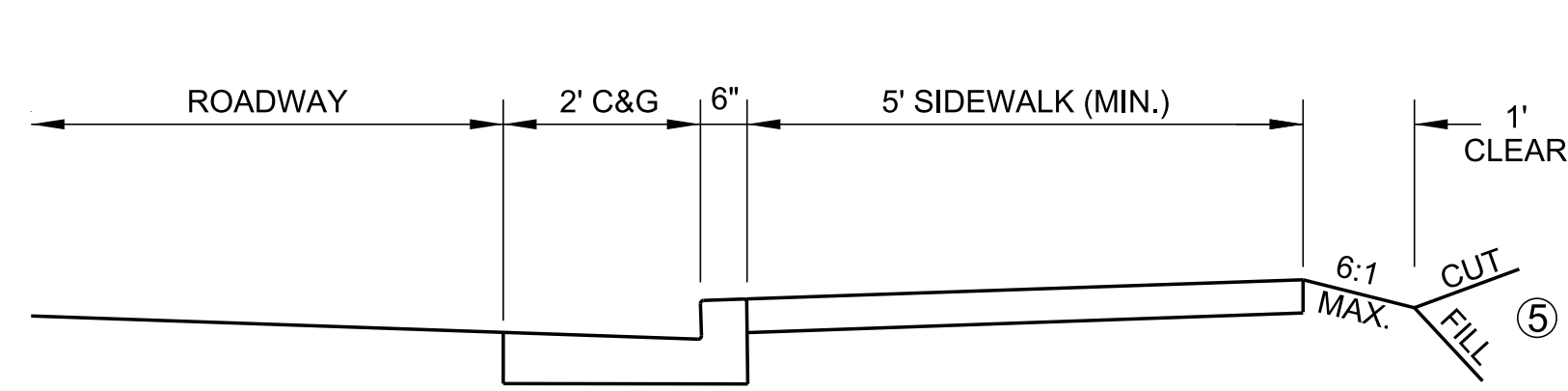

SIDEWALK ADJACENT TO CURB & GUTTER

SPEEDS ≤ 25 MPH ⑥

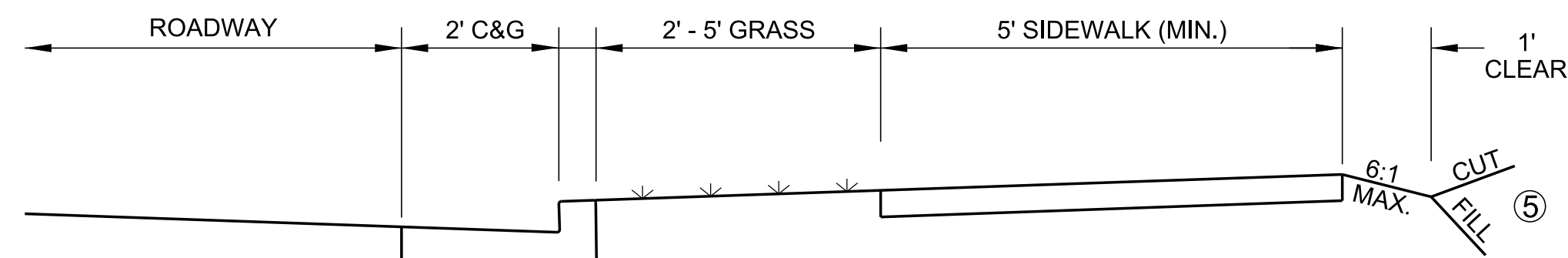

SIDEWALK W/ GRASS STRIP IN FRONT OF CURB & GUTTER

SPEEDS ≤ 35 MPH ⑦

SPEEDS ≤ 45 MPH ⑧

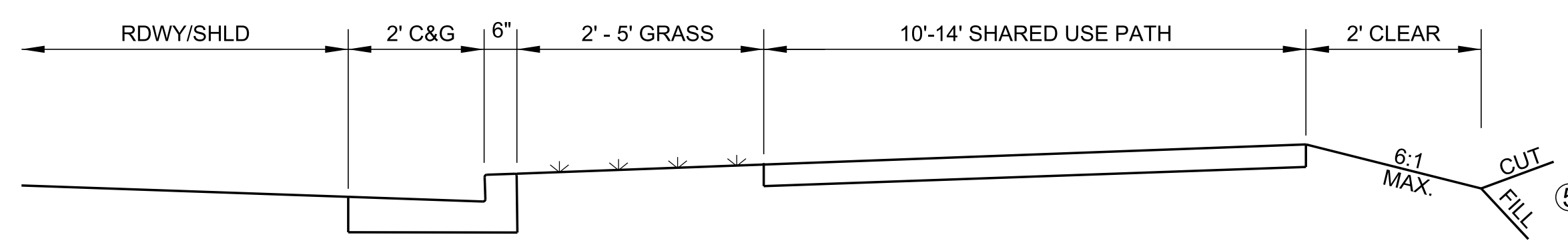

SHARED USE PATH

SPEEDS ≤ 45 MPH ⑧

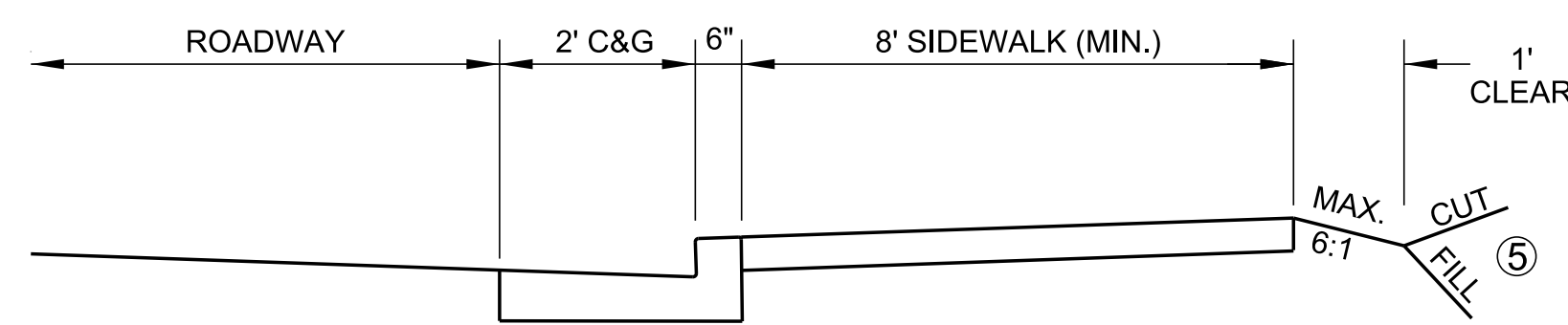

URBAN/COMMERCIAL CROSS SECTION WITH AN 8' SIDEWALK

SPEEDS ≤ 45 MPH ⑨

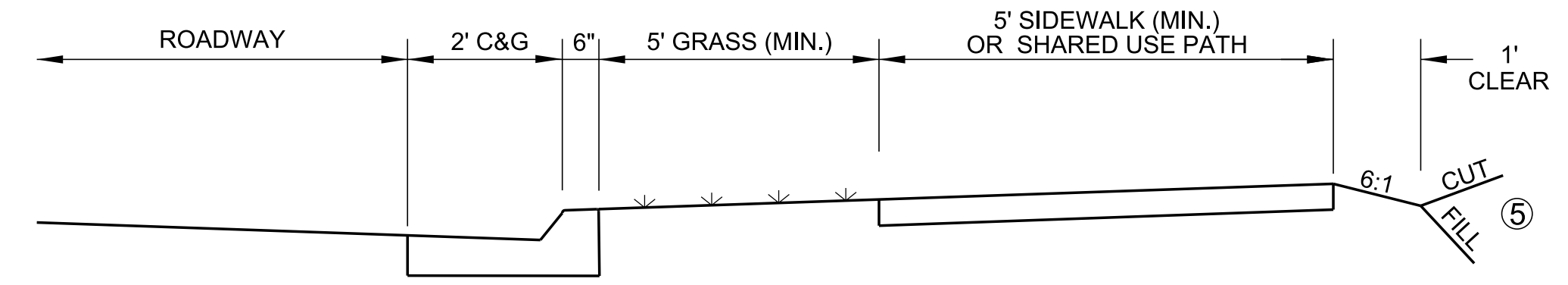

SIDEWALK W/ GRASS STRIP IN FRONT OF CURB & GUTTER

SPEEDS ≤ 55 MPH ⑩

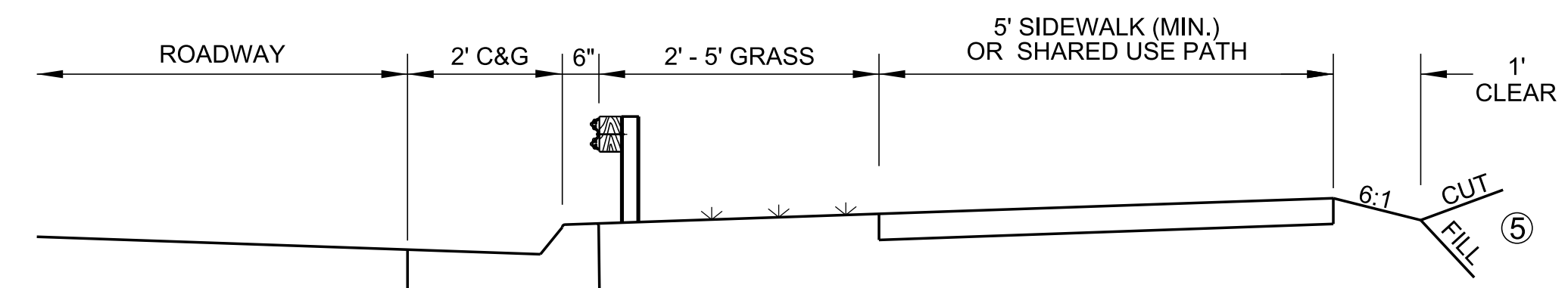

PROTECTED SIDEWALK W/ GRASS STRIP IN FRONT OF CURB & GUTTER

SPEEDS ≤ 55 MPH ⑩

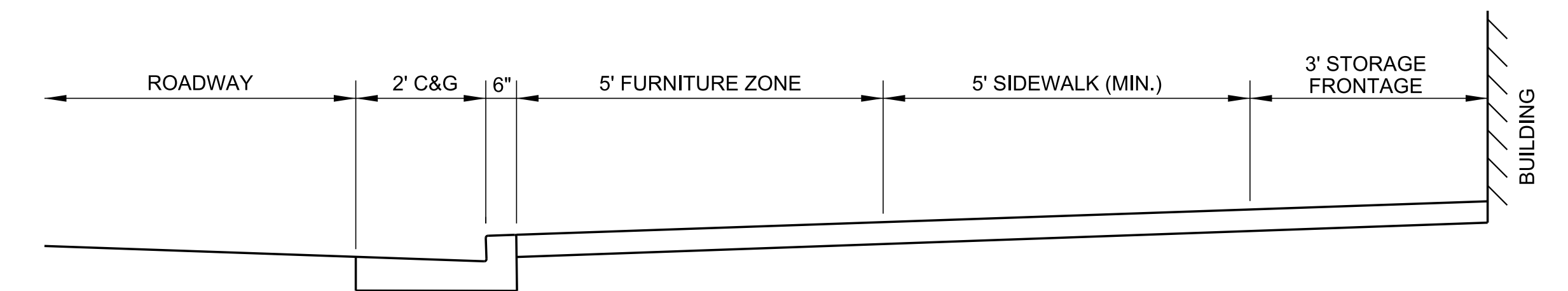

SIDEWALK IN CENTRAL BUSINESS DISTRICT/COMMERCIAL AREA

SPEEDS ≤ 35 MPH ⑦

GENERAL NOTES

- ① THE INTENT OF THIS DRAWING IS TO PROVIDE MINIMUM PEDESTRIAN ACCOMMODATION DESIGN CRITERIA FOR RESURFACING AND NEW PROJECTS.
- ② BARRIER BETWEEN SIDEWALK/SHARED USE PATH AND ROADWAY SHOULD BE USED WHEN SIDEWALK/SHARED USE PATH IS PLACED WITHIN CLEAR ZONE OR MINIMUM LATERAL OFFSET CANNOT BE MAINTAINED. SEE STANDARD DRAWING S-SSMB-9.
- ③ 5' LATERAL OFFSET RECOMMENDED FOR SHARED USE PATHS.
- ④ 1.5% CROSS SLOPE DESIRABLE, 2% CROSS SLOPE MAXIMUM.
- ⑤ SEE STANDARD DRAWING S-BPR-1 FOR GUIDANCE REGARDING SAFETY REQUIREMENTS.
- ⑥ FOR LOCAL ROADS AND STREETS WITH VERY LOW TRUCK/BUS TRAFFIC, OFFSET MAY BE REDUCED TO 0'.
- ⑦ TYPICAL SECTION WITH CURB AND GUTTER AND 2' GRASS STRIP PROVIDES MINIMUM 4.5' OF LATERAL OFFSET.
- ⑧ SPEEDS HIGHER THAN 45 MPH REQUIRE MINIMUM LATERAL OFFSET OF 7' (12' LATERAL OFFSET IS DESIRED). THIS CAN BE ACCOMPLISHED BY EITHER WIDER GRASS STRIPS (5') WITHOUT SHOULDER, OR 2' MINIMUM GRASS STRIP WITH 4' MINIMUM PAVED SHOULDER.
- ⑨ MINIMUM OFFSET MAY BE REDUCED TO 0' AT LOCATIONS WHERE POSTED SPEED IS ≤ 25 MPH.
- ⑩ 6" SLOPING CURB MUST BE USED ON ALL NEW PROJECTS AND IS HIGHLY ENCOURAGED ON RESURFACING PROJECTS. IF PEDESTRIAN FACILITY IS IN THE CLEAR ZONE, USE OF A BARRIER IS REQUIRED.
- ⑪ ALL DIMENSIONS SHOW THE ABSOLUTE MINIMUM VALUE.
- ⑫ THE DESIGNER, IF POSSIBLE, SHALL PROVIDE PEDESTRIAN FACILITY ACCOMMODATIONS THAT EXCEED THE MINIMUM SHOWN IN THIS DRAWING.

BIKE ACCOMMODATION DESIGN GUIDANCE FOR RESURFACING PROJECTS ON EXISTING FACILITIES WITHIN THE EXISTING RIGHT-OF-WAY

TYPICAL ROADWAY SECTION ELEMENTS TO ACCOMMODATE BIKE FACILITY

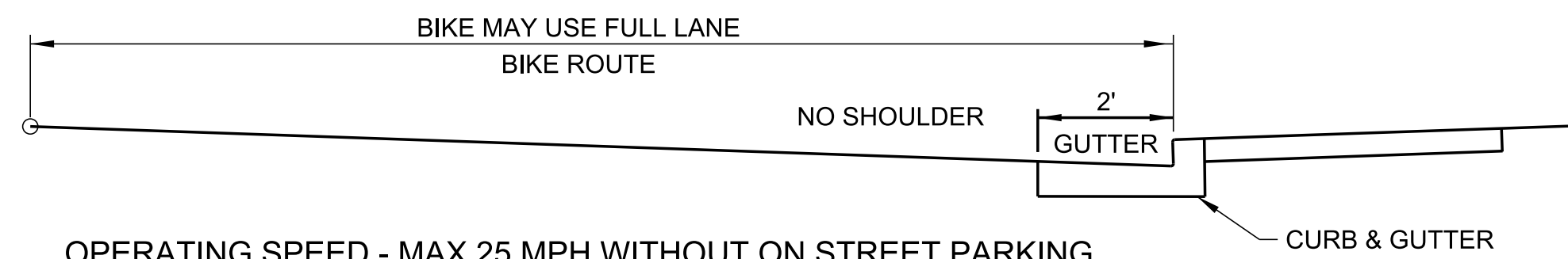

OPERATING SPEED - MAX 25 MPH WITHOUT ON STREET PARKING
WITH "BIKE MAY USE FULL STREET" SIGN. SEE STANDARD DRAWING T-M-11
FOR PAVEMENT MARKING AND SIGNING.

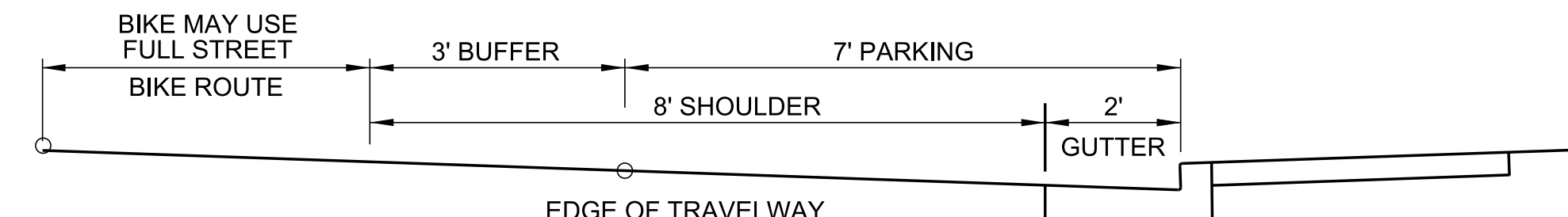

OPERATING SPEED - MAX 25 MPH WITH ON STREET PARKING
WITH "BIKE MAY USE FULL STREET" SIGN

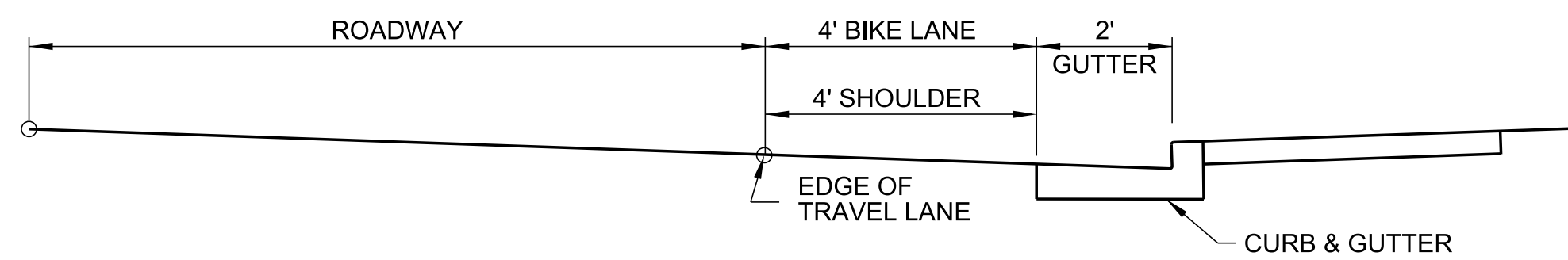

OPERATING SPEED - < 35 MPH BIKE LANE
4' BIKE LANE. SEE STANDARD DRAWING T-M-11 FOR PAVEMENT MARKING AND SIGNING.

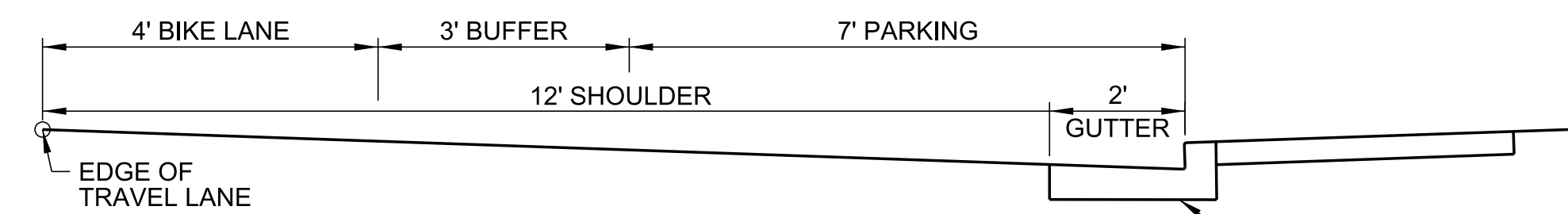

OPERATING SPEED - ≤ 35 MPH
BIKE LANE - WITH ON STREET PARKING
SEE STANDARD DRAWING T-M-11 FOR PAVEMENT MARKING AND SIGNING.

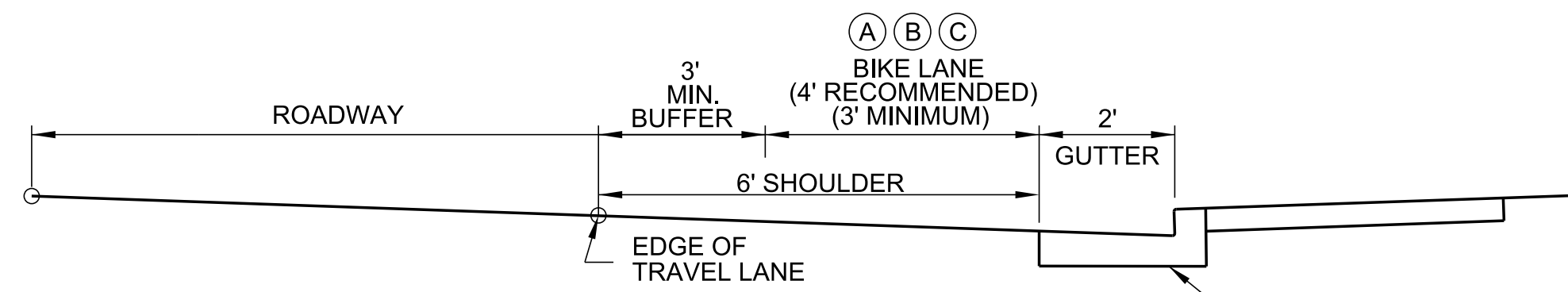

BUFFERED BIKE LANE
SEE STANDARD DRAWING T-M-11 FOR SIGNING AND PAVEMENT MARKING .

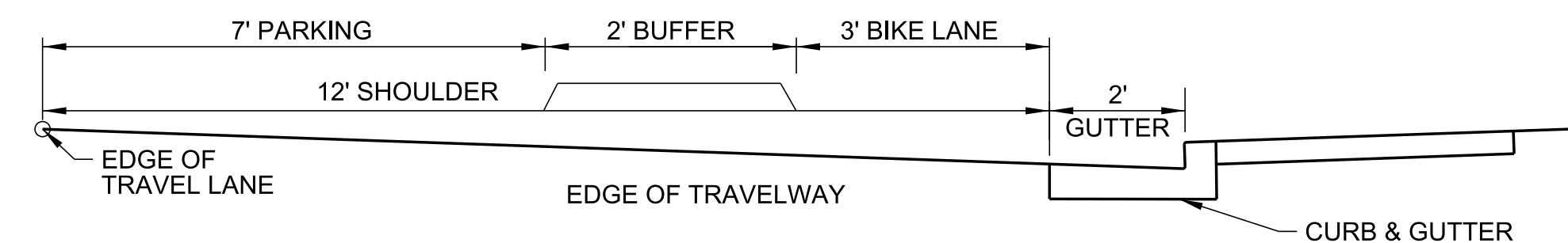

OPERATING SPEED - ≤ 45 MPH
ALTERNATIVE PROTECTED BIKE LANE - WITH ON STREET PARKING
SEE STANDARD DRAWING T-M-11 FOR PAVEMENT MARKING AND SIGNING.

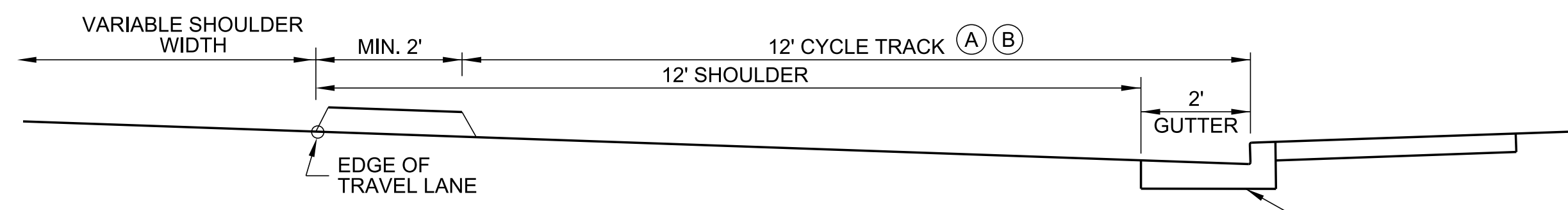

2' WIDE RAISED
6" SLOPING CURB
ISLAND OR GROUND
MOUNTED DELINEATORS
WITH 3' BUFFER

OPERATING SPEED - ≤ 45 MPH
CYCLE TRACK - SEPARATED BIKE LANE

- (A) MIN. 3' BUFFER IF OPERATING SPEED <45 MPH
- (B) MIN. 4' BUFFER IF OPERATING SPEED 45-50 MPH (8' SHOULDER, USE 6" SLOPING CURB)
- (C) MIN. 6' BUFFER IF OPERATING SPEED 50-55 MPH (10' SHOULDER, USE 6" SLOPING CURB)

GENERAL NOTES

- 1 THE INTENT OF THIS DRAWING IS TO PROVIDE MINIMUM BIKE ACCOMMODATION DESIGN GUIDANCE FOR RESURFACING PROJECTS THAT IS BASED ON THE EXISTING AVAILABLE SHOULDER WIDTH.
- 2 SEE STANDARD DRAWINGS T-M-11 AND T-M-12 FOR PAVEMENT MARKING AND SIGNING.
- 3 ALL DIMENSIONS SHOW THE ABSOLUTE MINIMUM VALUE.
- 4 THE DESIGNER, IF POSSIBLE, SHALL PROVIDE BIKE ACCOMMODATIONS THAT EXCEED THE MINIMUM SHOWN IN THIS DRAWING.