

# Applied Math for Distribution Systems

## Course #1102



Department of  
**Environment &  
Conservation**



# Applied Math for Distribution

State of Tennessee

COURSE # 1102 / 1102-V

APRIL 18 - 22, 2022

INSTRUCTOR: AMANDA CARTER

## Monday

8:30 Basic Math Review  
11:00 LUNCH  
12:15 Dimensional Analysis and Conversions

## Tuesday

8:30 Circumference, Area & Volume  
11:00 LUNCH  
12:15 Velocity and Flow

## Wednesday

8:30 Disinfection  
11:00 LUNCH  
12:15 Laboratory Calculations

## Thursday

8:30 Pumps, Pressure, & Power  
11:00 LUNCH  
12:15 Miscellaneous  
2:00 Test Review

## Friday

8:30 Review  
9:30 Exam

State of Tennessee

Fleming Training Center  
2022 Blanton Dr.  
Murfreesboro, TN 37129

Phone: 615-898-6507

Fax: 615-898-8064

E-mail: [Amanda.Carter@tn.gov](mailto:Amanda.Carter@tn.gov)





## **Table of Contents**

Section 1	Basic Math Review	3
Section 2	Dimensional Analysis	27
Section 3	Circumference, Area and Volume	49
Section 4	Velocity and Flow	83
Section 5	Disinfection	105
Section 6	Pumps, Pressure & Power	123
Section 7	Miscellaneous	155
Section 8	Laboratory Calculations	171



## **Section I**

### **Basic Math Review**

# MATH FUNDAMENTALS REVIEW

Applied Math for Distribution Systems



## FRACTIONS

- Numerator
  - Top portion of a fraction
  - Indicates how many parts are being considered
- Denominator
  - Bottom portion of fraction
  - Tells how many equal parts the whole has been divided into

$$\frac{\text{Numerator}}{\text{Denominator}}$$
A diagram showing a fraction with "Numerator" above a horizontal line and "Denominator" below it. An arrow points from the text "Division line" to the horizontal line.



## EQUIVALENT FRACTIONS

- Fractions with different numerators and denominators that refer to the same portion
- Fractions that represent equal parts of the whole



One  
Whole



$\frac{1}{2}$



$\frac{2}{4}$



$\frac{4}{8}$

## DECIMAL SYSTEM

- The word decimal comes from the Latin word meaning *decem*, meaning ten.
- The decimal system is based on ten and multiples of ten.
- In a place value system the size of any number depends on two things:
  - Which digits are used and
  - Where these digits are placed in relation to the decimal point

thousands	hundreds	tens	ones	●	tenths	hundredths	thousandths	Ten thousandths
1000	100	10	1		$\frac{1}{10}$	$\frac{1}{100}$	$\frac{1}{1000}$	$\frac{1}{10,000}$
← Greater than one					Less than one →			

## PERCENTAGES

- Method of comparing one quantity with another
- *Percent* comes from Latin words *per centum*, meaning “by the hundreds”
- Indicates “how many per hundred”
  - Example: If 4 percent (%) of bac’t bottles expire, then 4 out of every 100 bottles expire.
- Three ways to convey this mathematically:
  - Percent: 4%
  - Fraction:  $\frac{4}{100}$
  - Decimal: 0.04

## CONVERTING DECIMALS AND FRACTIONS

- To convert a fraction to a decimal
  - Simply divide the numerator by the denominator

$$\frac{1}{2} = 1 \div 2 = 0.5$$

$$\frac{10}{13} = 10 \div 13 = 0.7692$$

## PERCENTS & DECIMALS

- To convert from a decimal to a percent:

Option 1: Move the decimal point two places to the right.

Example: Express 0.46 as a decimal.

$$\begin{array}{c} \uparrow \uparrow \\ 0.46 = 46.0\% \end{array}$$

Option 2: Multiply decimal by 100.

Example: Express 0.46 as a decimal.

$$0.46 \times 100 = 46.0\%$$

## PERCENTS & DECIMALS

- To convert from a percent to a decimal:

Option 1: Move decimal point two places to the right.

Example: Express 82% as a decimal number.

$$82\% = 82.0\%$$

$$\begin{array}{c} \uparrow \uparrow \\ 82.0\% = 0.82 \end{array}$$

Option 2: Divide decimal by 100.

$$82 \div 100 = 0.82$$

## CALCULATING PERCENT PROBLEMS

- The following equation may be used to calculate percent:

$$\% = \frac{\text{Part}}{\text{Whole}} \times 100\%$$

- Example: 17 is what percent of 54?

$$\% = \frac{17}{54} \times 100\%$$

$$\% = 0.31 \times 100\%$$

$$\% = 31\%$$

## ROUNDING NUMBERS

- Rounding* means making a number simpler but keeping its value close to what it was.
  - The result is less accurate, but easier to use.
- Procedure depends the relationship between the number to the right of the “rounding place” and five (5)
  - If the digit is less than 5, round down.
  - If the digit is 5 or greater, round up.

### Rounding

**Find the digit**  
**Look next door**  
**Five or higher**  
**add one more**  
**four or less**  
**Let it rest**

## TERMINOLOGY

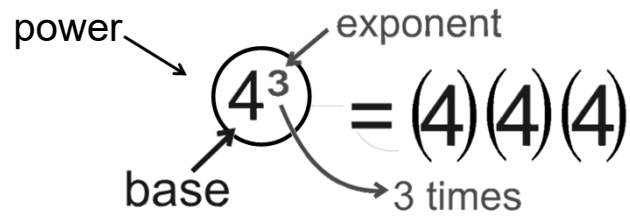

- The *base* is the number that is being multiplied.
- An *exponent* refers to the number of times a number is multiplied by itself.
  - Written as a small number to the right and above the base number
  - Also called powers or indices
- The entire expression is called a *power*.

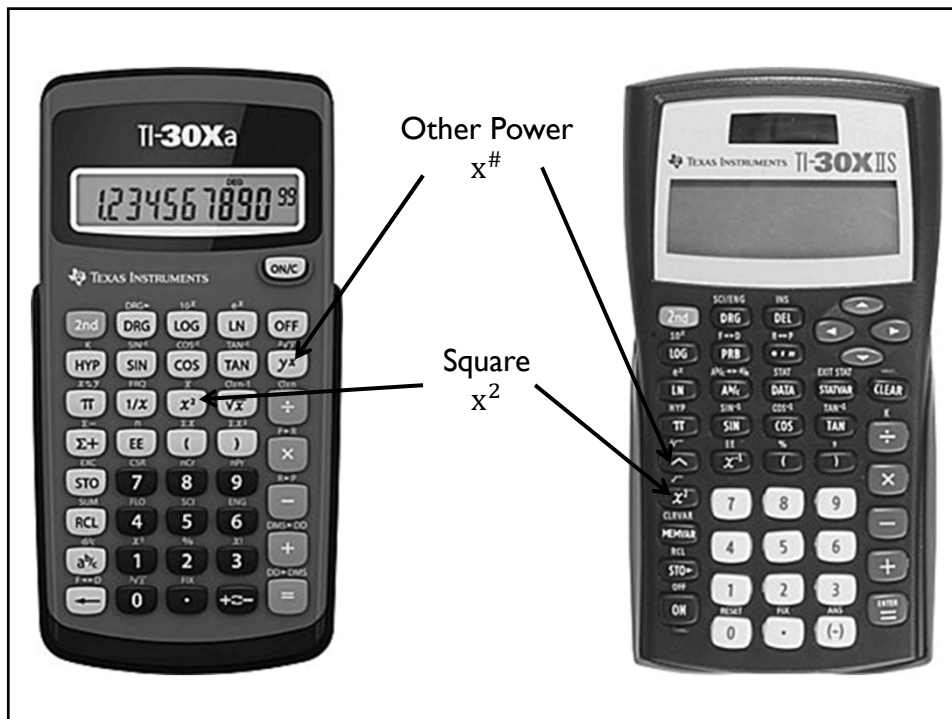

## EXPONENTS EXAMPLES

- Solve the following expressions:

$$8^2$$

$$64$$

$$9.72^{5.1}$$

$$108,917.57$$

$$2401^{1/4}$$

$$7$$

$$x^3$$

$$(x)(x)(x)$$

## ROOTS

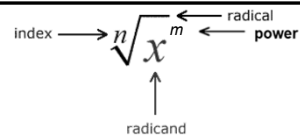

- A root is a number which, when multiplied together a given number of times, equals the original number.
  - Square root: factor when multiplied together two (2) times
  - Cubed root: factor when multiplied together three (3) times
  - If a number is not written with the root, it is assumed to be 2.
- A root is the inverse (opposite) operation of an exponent.

$$\sqrt[2]{100} = 10$$

$$\sqrt{361} = \square$$

$$\sqrt{144} = 12$$

$$\sqrt[3]{27} = 3$$

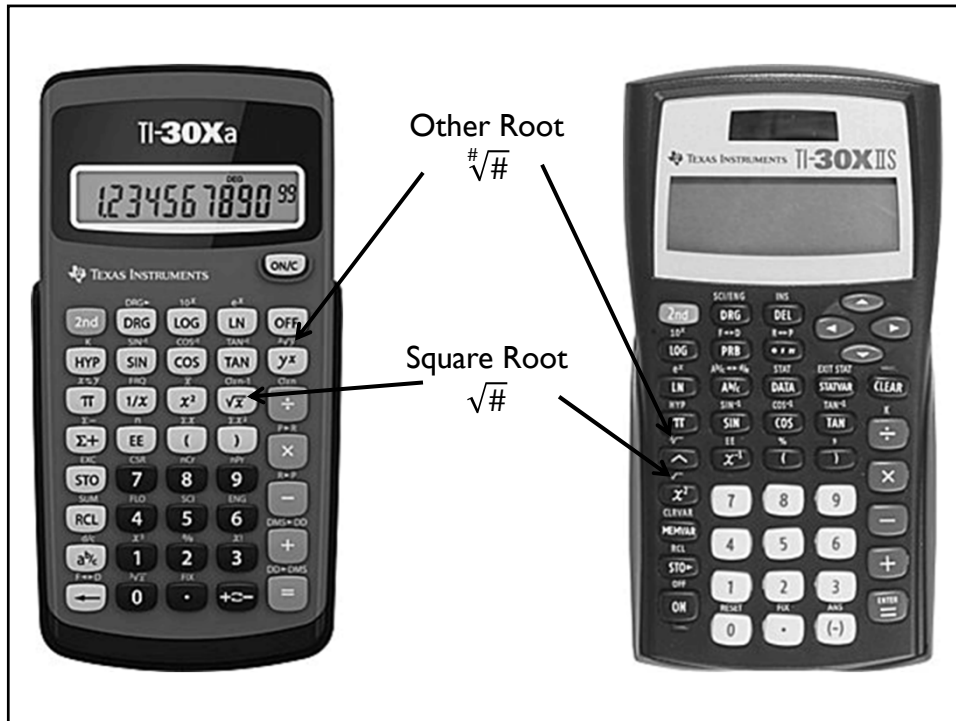

ROOTS EXAMPLES

$$\overset{\text{index}}{\longrightarrow} \sqrt[n]{x^m} \longleftarrow \begin{matrix} \text{radical} \\ \text{power} \end{matrix}$$

$\uparrow$   
radicand

- Solve the following expressions:

$\sqrt[2]{100} = \square$ $\sqrt{361} = \square$	$\sqrt{144} = \square$ $\sqrt[3]{27} = \square$
-----------------------------------------------------	----------------------------------------------------

## ORDER OF OPERATIONS

- Parenthesis
- Exponents
- Multiplication/Division
- Addition/Subtraction

PEMDAS

P E MD AS

$$\begin{array}{r} 8 + 16 \div 4 \\ 24 \div 4 \\ 6 \end{array}$$

$$\begin{array}{r} 8 + 16 \div 4 \\ 8 + 4 \\ 12 \end{array}$$

## KEY WORDS

- Of  $\longrightarrow$  multiply  
 $5\% \text{ of } 100 = 0.05 \times 100$
- Per  $\longrightarrow$  divide  
 $25 \text{ miles per gallon} = 25 \frac{\text{miles}}{\text{gallon}}$
- Is  $\longrightarrow$  equals



## SOLVING FOR AN UNKNOWN VALUE (X)

Applied Math for Distribution Systems



## SOLVING FOR X

- Solve for X

$$(4)(1.5)(x) = 1200$$

- X must be by itself on one side of equal sign
  - 4 and 1.5 must be moved away from X

$$x = \frac{1200}{(4)(1.5)}$$

$$x = 200$$

- How was this accomplished?

## MOVEMENT OF TERMS

- To understand how we move the numbers, we will need to consider more closely the math concepts associated with moving the terms.
- An equation is a mathematical statement in which the terms or calculation on one side equals the terms or calculation on the other side.

## MOVEMENT OF TERMS

$$3 * 6 = 2 * 9$$
$$18 = 18$$

$$\square 3 * 6 = 2 * 9 \square$$
$$25 \neq 18$$
$$25 = 25$$

Whatever you do to one side of the equation, you have to do to the other to maintain that “balance.”

## MOVEMENT OF TERMS

- When dealing with a variable, you want to get the variable by itself.
- This is done by performing the opposite function  
 $(3)(x) = 96$
- Since  $X$  is multiplied by 3, you can get rid of the 3 by using the opposite process: division.

## MOVEMENT OF TERMS

$$(3)(x) = 96$$

- What is keeping  $X$  from being alone?
- What is 3 doing to  $X$ ?
- To move 3, we have to do the opposite.
- Whatever you do to one side, you have to do to the other.

## MOVEMENT OF TERMS

$$\cancel{2}(x) = 96$$

=

- To preserve the equation, you must divide the other side of the equation as well.
- Since both sides of the equation are divided by the same number, the value of the equation remains unchanged.

## EXAMPLE 3

What you do to one side of the equation, must be done to the other side.

$$730 = \frac{x}{3847}$$

$$730 = \frac{x}{\cancel{3847}}$$

$$3847 \times 730 = x$$

$$2,808,310 = x$$

### EXAMPLE 3

Simplify

$$0.5 = \frac{(165)(3)(8.34)}{x}$$

What you do to one side of the equation, must be done to the other side.

$$\boxed{\phantom{x}} \cdot 0.5 = \frac{4128.3}{\cancel{x}} \boxed{\phantom{x}}$$

$$(x)(\cancel{0.5}) = 4128.3$$

$$\boxed{\phantom{x}} = \boxed{\phantom{4128.3}}$$

$$x = \frac{4128.3}{0.5}$$

$$x = 8256.6$$

### SOLVING FOR X WHEN SQUARED

- Follow same procedure as solving for X
- Then take the square root

$$x^2 = 15,625$$

$$\sqrt{x^2} = \sqrt{15,625}$$

$$x = 125$$

**EXAMPLE 3**

$$(0.785)(x^2) = 2826$$

$$\cancel{(0.785)}(x^2) = 2826$$
$$\boxed{\phantom{0.785}} = \boxed{\phantom{2826}}$$

$$x^2 = \frac{2826}{0.785}$$

$$\textcircled{x^2} = 3600$$

$$\sqrt{x^2} = \sqrt{3600}$$

$$x = 60$$

## Basic Math Review Example Problems

1.  $8.1 = (3)(x)(1.5)$

2.  $109 = \frac{x}{(0.785)(80)(80)}$

3.  $2.5 = \frac{1,270,000}{x}$

4.  $(x^2)(10)(7.48) = 10,771.2$

## Basic Math

### Solving for the Unknown

1.  $16 = (2)(x)$

2.  $(0.785)(0.33)(0.33)(x) = 0.49$

3.  $\frac{10}{x} = 50$

4.  $56.5 = \frac{3800}{(x)(8.34)}$

5.  $10 = \frac{x}{4}$

6.  $940 = \frac{x}{(0.785)(90)(90)}$



$$7. \quad x = \frac{(165)(3)(8.34)}{0.5}$$

$$8. \quad 114 = \frac{(230)(1.15)(8.34)}{(0.785)(70)(70)}$$

$$9. \quad 2 = \frac{x}{180}$$

$$10. \quad 46 = \frac{(105)(x)(8.34)}{(0.785)(100)(100)(4)(x)}$$

$$11. \quad 2.4 = \frac{(0.785)(5)(5)(4)(7.48)}{x}$$

$$12. \quad \frac{(15)(12)(1.25)(7.48)}{x} = 337$$

$$13. \quad \frac{x}{(4.5)(8.34)} = 213$$

$$14. \quad \frac{x}{246} = 2.4$$

$$15. \quad 6 = \frac{(x)(0.18)(8.34)}{(65)(1.3)(8.34)}$$

$$16. \quad \frac{(3000)(3.6)(8.34)}{(0.785)(x)} = 23.4$$

$$17. \quad 109 = \frac{x}{(0.785)(80)(80)}$$

$$18. \quad (x)(3.7)(8.34) = 3620$$

$$19. \quad 2.5 = \frac{1,270,000}{x}$$

$$20. \quad 0.59 = \frac{(170)(2.42)(8.34)}{(1980)(x)(8.34)}$$

$$21. \quad x^2 = 100$$

$$22. \quad (2)(x^2) = 288$$

$$23. \quad 942 = (0.785)(x^2)(12)$$

$$24. \quad 6358.5 = (0.785)(x^2)$$

$$25. \quad 835 = \frac{4,200,000}{(0.785)(x^2)}$$

$$26. \quad 920 = \frac{3,312,000}{x^2}$$

$$27. \quad 23.9 = \frac{(3650)(3.95)(8.34)}{(0.785)(x^2)}$$

$$28. \quad (0.785)(D^2) = 5,024$$

$$29. \quad (x^2)(10)(7.48) = 10,771.2$$

$$30. \quad 51 = \frac{64,000}{(0.785)(x^2)}$$

$$31. \quad (0.785)(D^2) = 0.54$$

$$32. \quad 2.1 = \frac{(0.785)(D^2)(15)(7.48)}{(0.785)(80)(80)}$$

$$33. \quad (x)(3.7)(8.34) = 3620$$

$$34. \quad (0.785)(D^2) = 5024$$

## Answers

1.	18.
2.	19.
3.	20.
4.	21.
5.	22.
6.	23.
7.	24.
8.	25.
9.	26.
10.	27.
11.	28.
12.	29.
13.	30.
14.	31.
15.	32.
16.	33.
17.	34.

## **Section 2**

### **Dimensional Analysis**



## Dimensional Analysis

Applied Math for Distribution Systems

Mathematics Manual for Water and Wastewater Treatment plant Operators  
by Frank R. Spellman

## Dimensional Analysis

- ▶ The process of manipulating our units of measurement is called *dimensional analysis*.
- ▶ An easy way to think of this is to imagine a ruler that has inches on one side and centimeters on the other.
  - ▶ If we measure a piece of string with either side, we get two different numbers with different units, but they represent the same real-world length.
- ▶ That is the goal of dimensional analysis: to get the same real-world value represented with different units.





## Dimensional Analysis - Example

---

Set up a conversion to change 756 centimeters into inches.

1. Identify starting factor: 756 cm
2. Identify answer units: inches
3. Determine conversion factor(s) needed: 1 in = 2.54 cm
4. Set up original factor to multiply conversion factor.
  - Ensure correct set up by paying attention to the units.

$$\left(\frac{756 \text{ cm}}{1}\right)\left(\frac{1 \text{ inch}}{2.54 \text{ cm}}\right) = ?$$

$$\frac{(756)(\text{cm})(1)(\text{inch})}{(1)(2.54)(\text{cm})} = ?$$

---

## Dimensional Analysis - Example

---

Set up a conversion to change 756 cm into inches. (cont'd)

5. Eliminate common factors in numerator and denominator (cancel like units).

$$\frac{(756)(\cancel{\text{cm}})(1)(\text{inch})}{(1)(2.54)(\cancel{\text{cm}})}$$

6. Simplify the fractions.

$$\frac{(756) \text{ inch}}{(1)(2.54)}$$

7. Solve.

$$297.64 \text{ in}$$

---

## Example 1

---

- ▶ Convert 1800 ft<sup>3</sup> into gallons.
- ▶ We need the conversion factor that connects the two units

$$1 \text{ cubic foot of water} = 7.48 \text{ gal}$$

- ▶ This is a ratio, so it can be written two different ways

$$\frac{1 \text{ ft}^3}{7.48 \text{ gal}} \quad \text{OR} \quad \frac{7.48 \text{ gal}}{1 \text{ ft}^3}$$

- ▶ We want to use the version that allows us to cancel out units
- 

$$\frac{1 \text{ ft}^3}{7.48 \text{ gal}} \quad \text{OR} \quad \frac{7.48 \text{ gal}}{1 \text{ ft}^3}$$

## Example 1

---

$$\left( \frac{1800 \text{ ft}^3}{1} \right) \boxed{\phantom{0000}} \boxed{\phantom{0000}}$$

- ▶ Will anything cancel out?

NO

- ▶ Let's try the other version

$$\boxed{\phantom{00000000}} \boxed{\phantom{00000000}}$$

- ▶ Will anything cancel out?

YES

$$\boxed{\phantom{0000}} \boxed{\phantom{0000}}$$

---

## Units and Variables

---

- Remember, units of measure and variables (x) function the same as numbers.

$$\text{ft}^3 = (\text{ft})(\text{ft})(\text{ft})$$

$$x^2 = (x)(x)$$

$$\frac{4.5 \text{ ft}^3}{1.5 \text{ ft}^2} = \boxed{\phantom{000}} \boxed{\phantom{000}}$$

---

## Dimensional Analysis & Complex Fractions

---

- Example:  $(4140 \text{ gpm}) \div \left(60 \frac{\text{sec}}{\text{min}}\right) = ? \text{ gps}$

$$\frac{4140 \text{ gal}}{\frac{1 \text{ min}}{\frac{60 \text{ sec}}{1 \text{ min}}}} = ? \text{ gps}$$

Invert the Denominator

$$\frac{60 \text{ sec}}{1 \text{ min}} \text{ becomes } \frac{1 \text{ min}}{60 \text{ sec}}$$

$$\left(\frac{4140 \text{ gal}}{1 \text{ min}}\right) \times \left(\frac{1 \text{ min}}{60 \text{ sec}}\right) = ? \text{ gps}$$

Before it divided, now it multiplies.

$$\frac{(4140 \text{ gal})(\cancel{1 \text{ min}})}{(\cancel{1 \text{ min}})(60 \text{ sec})} = ? \text{ gps}$$

$$? \text{ gps} = \boxed{\phantom{000}} \boxed{\phantom{000}}$$

---

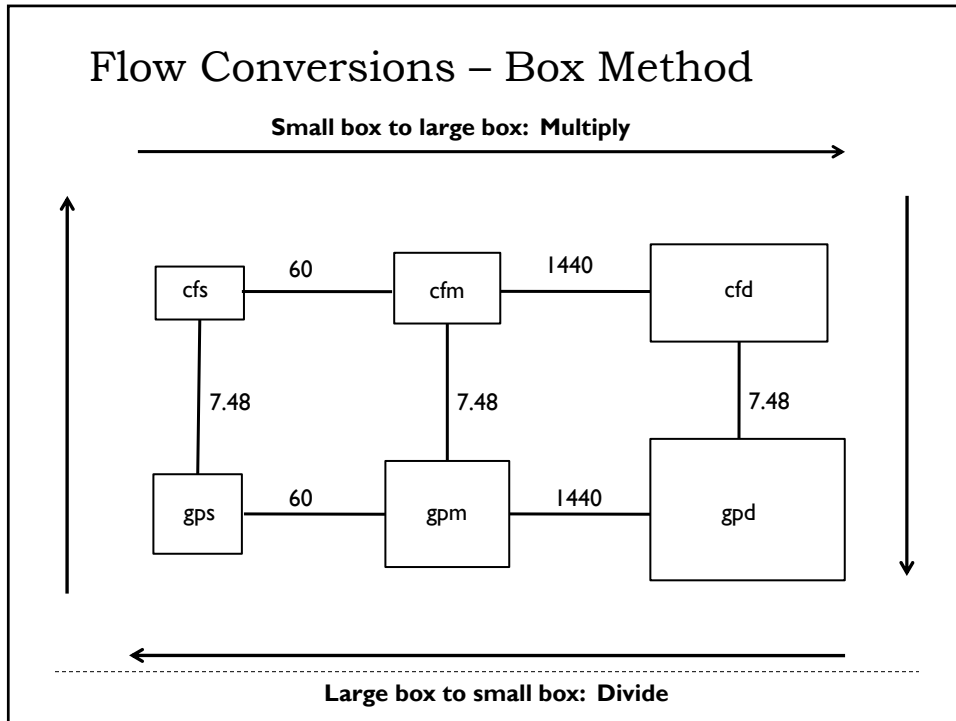

### Metric Units

---

Kilo	Hecto	Deca	Basic Unit	Deci	Centi	Milli
King	Henry	Died	By	Drinking	Chocolate	Milk
1000X larger	100X larger	10X larger	Meter Liter Gram <i>1 unit</i>	10X smaller	100X smaller	1000X smaller

**MULTIPLY** numbers by 10 if you are getting smaller

**DIVIDE** number by 10 if you are getting bigger

---

## Metric Units

---

<b>King</b>	<b>Henry</b>	<b>Died</b>	<b>by</b>	<b>Drinking</b>	<b>Chocolate</b>	<b>Milk</b>
k	h	d	base	d	c	m

- Convert 2500 milliliters to liters

$$\underline{2500} \text{ mL} = \boxed{\phantom{000}}$$

- Convert 0.75 km into cm

$$\underline{0.75} \text{ km} = \boxed{\phantom{0000}}$$

---

## Dimensional Analysis Example

1. Convert 5 cubic feet to gallons.
2. Convert  $56 \text{ ft}^3/\text{sec}$  to gallons per minute.
3. Convert 3.45 MGD to cubic feet per second.
4. How many mL are in 0.75 L?

## General Conversions Practice Problems

1.  $325 \text{ ft}^3 =$  gal
2.  $2512 \text{ kg} =$  lb
3.  $2.5 \text{ miles} =$  ft
4.  $1500 \text{ hp} =$  kW
5.  $2.2 \text{ ac-ft} =$  gal
6.  $2100 \text{ ft}^2 =$  ac
7.  $92.6 \text{ ft}^3 =$  lb
8.  $17,260 \text{ ft}^3 =$  MG
9.  $0.6\% =$  mg/L
10.  $30 \text{ gal} =$   $\text{ft}^3$
11. A screening pit must have a capacity of  $400 \text{ ft}^3$ . How many lbs is this?
12. A reservoir contains  $50 \text{ ac-ft}$  of water. How many gallons of water does it contain?

13.  $3.6 \text{ cfs} = \underline{\hspace{2cm}} \text{ gpm}$

14.  $1820 \text{ gpm} = \underline{\hspace{2cm}} \text{ gpd}$

15.  $45 \text{ gps} = \underline{\hspace{2cm}} \text{ cfs}$

16.  $8.6 \text{ MGD} = \underline{\hspace{2cm}} \text{ gpm}$

17.  $2.92 \text{ MGD} = \underline{\hspace{2cm}} \text{ lb/min}$

18.  $385 \text{ cfm} = \underline{\hspace{2cm}} \text{ gpd}$

19.  $1,662 \text{ gpm} = \underline{\hspace{2cm}} \text{ lb/day}$

20.  $3.77 \text{ cfs} = \underline{\hspace{2cm}} \text{ MGD}$

21. The flow through a pipeline is 8.4 cfs. What is the flow in gpd?

22. A treatment plant receives a flow of 6.31 MGD. What is the flow in cfm?

**General Conversions**

1. 2,431 gal

2. 5,533 lb

3. 13,200 ft

4. 1,119 kW

5. 717,200 gal

6. 0.05 ac

7. 5,778.24 lb

8. 0.13 MG

9. 6,000 mg/L

10. 4.01 ft<sup>3</sup>

11. 24,960 lb

12. 16,300,000 gal

13. 1,615.68 gal/min

14. 2,620,800 gal/day

15. 6.02 ft<sup>3</sup>/sec

16. 5,973.22 gpm

17. 16,911.67 lb/min

18. 4,146,912 gal/day

19. 19,959,955.2 lb/day

20. 2.43 MGD

21. 5,428,684.8 gal/day

22. 585.82 ft<sup>3</sup>/min



## Basic Conversions Extra Problems

1. How many seconds are in a minute?
2. How many minutes are in an hour?
3. How many hours in a day?
4. How many minutes in a day?
5. How many inches in a foot?
6. How many feet in a mile?
7. How many feet in a meter?
8. How many meters in a mile?
9. How much does one gallon of water weigh?
10. How much does one cubic foot of water weigh?

11. Express a flow of 5 cfs in terms of gpm.
  
12. What is 38 gps expressed as gpd?
  
13. What is 0.7 cfs expressed as gpd?
  
14. What is 9164 gpm expressed as cfs?
  
15. What is 1.2 cfs expressed as MGD?
  
16. Convert 65 gpm into lbs/day.
  
17. Convert 345 lbs/day into gpm.
  
18. Convert 0.9 MGD to cfm.

19. Convert 1.2 MGD to  $\text{ft}^3/\text{hour}$ .
20. Convert a flow of 4,270,000 gpd to cfm.
21. What is 5.6 MGD expressed as cfs?
22. Express 423,690 cfd as gpm.
23. Convert 2730 gpm to gpd.
24. Convert 1440 gpm to MGD.
25. Convert 45 gps to  $\text{ft}^3/\text{day}$ .

**Basic Conversions Extra Problems**

1. 60 sec/min
2. 60 min/hr
3. 24 hr/day
4. 1440 min/day
5. 12 in/ft
6. 5280 ft/mi
7. 3.28 ft
8. 1610 m/mi
9. 8.34 lbs/gal
10. 62.4 lbs/ft<sup>3</sup>
11. 2244 gpm
12. 3,283,200 gpd
13. 452,390 gpd
14. 20.42 cfs
15. 0.78 MGD
16. 780,624 lbs/day
17. 0.03 gpm
18. 83.56 ft<sup>3</sup>/min
19. 6684.49 ft<sup>3</sup>/hr
20. 396.43 ft<sup>3</sup>/min
21. 8.67 cfs
22. 2200.83 gpm
23. 3,931,200 gpd
24. 2.07 MGD
25. 519,786.10 ft<sup>3</sup>/day

## Metric System and Temperature Conversion Practice Problems

Convert the following.

1. 23 g into \_\_\_\_\_ mg
2. 12,456 m into \_\_\_\_\_ km
3. 4235 mL into \_\_\_\_\_ L
4. 200 mg into \_\_\_\_\_ kg
5. 1000 watts into \_\_\_\_\_ kW
6. 0.05 g into \_\_\_\_\_ cg
7. 20 deciliters into \_\_\_\_\_ mL
8. 140 kg into \_\_\_\_\_ g
9. 9.5 cm into \_\_\_\_\_ mm
10. 100 milliseconds into \_\_\_\_\_ seconds

**Answers**

1. 23,000 mg
2. 12.456 km
3. 4.235 L
4. 0.0002 kg
5. 1 kwatt
6. 5 cg
7. 2000 mL
8. 140,000 g
9. 95 mm
10. 0.1 seconds

## Conversions Practice Problems

1. Convert 723 gallons to liters.
- ~~2. Convert  $17^{\circ}\text{C}$  to degrees Fahrenheit.~~
3. How many feet are in 2.5 miles?
4. Convert 56 grains per gallon to mg/L.
5. Convert  $56 \text{ ft}^3/\text{s}$  to gallons per minute.
- ~~6. Convert  $34^{\circ}\text{C}$  to degrees Fahrenheit.~~
7. Calculate 42.0% of 7,310.
8. Convert 72 ppm to percent.
9. A solution was found to be 7.6% hypochlorite. How many milligrams per liter of hypochlorite are in the solution?
10. Convert 8.77 acre-ft to gallons.

11. Convert 1.98 acres to square feet.
12. Convert 81 ft<sup>3</sup> to Liters.
- ~~13. Convert 212°F to degrees Celsius.~~
14. Convert 1,472 L to gallons.
15. Convert 0.25 miles to yds.
16. Convert a chlorine solution of 2.5 ppm to percent.
17. Convert 2,367 g to pounds.
18. Convert 3.45 MGD to cubic feet per second.
19. Convert 63.5% to ppm.
20. What percent is 12,887 of 475,258?
- ~~21. Convert the following:  
451°F to degrees Celsius~~



22. 8,711,400 gal to acre-feet.
23. 35 cfs to gpm
24. 8 lb/sec to lb/day
25. 45 gal/min to ft<sup>3</sup>/day
26. 927 cfm to gps
27. 0.3 MGD to gal/hr
28. 89 cfd to cfs
29. 93 gal/sec to MGD
30. 2 ft<sup>3</sup>/min to gal/day
31. 17 gal/day to lb/min
32. 1.7 acre-foot to gal

33. 78 mg/L to lbs/gal
34. 890 lb/day to cfm
35. 10,600 gpd to ft<sup>3</sup>/sec
36. 900 grams to lbs
37. 29.78 lb/hr to gpd
38. 79 mL to gal
39. 830 yds/min to ft/day
40. 379 km/day to mph

**Conversion Answers:**

- |                              |                         |
|------------------------------|-------------------------|
| 1. 2,735.56 L                | 21. <del>232.78°C</del> |
| 2. <del>62.6°F</del>         | 22. 26.72 ac-ft         |
| 3. 13,200 ft                 | 23. 15,708 gpm          |
| 4. 957.6 mg/L                | 24. 691,200 lb/day      |
| 5. 25,132.8 gpm              | 25. 8,663.1 cfd         |
| 6. <del>93.2°F</del>         | 26. 115.57 gps          |
| 7. 3,070.2                   | 27. 12,500 gal/hr       |
| 8. 0.0072%                   | 28. 0.001 cfs           |
| 9. 76,000                    | 29. 8.04 MGD            |
| 10. 2,859,020 gal            | 30. 21,542.4 gpd        |
| 11. 86,248.8 ft <sup>2</sup> | 31. 0.098 lb/min        |
| 12. 2,293.3 L                | 32. 554,200 gal         |
| 13. <del>100°C</del>         | 33. 0.00065 lb/gal      |
| 14. 388.9 gal                | 34. 0.01 cfm            |
| 15. 440 yd                   | 35. 0.016 cfs           |
| 16. 0.00025%                 | 36. 1.98 lb             |
| 17. 5.21 lb                  | 37. 85.7 gpd            |
| 18. 5.34 cfs                 | 38. 0.02 gal            |
| 19. 635,000 mg/L             | 39. 3,585,600 ft/day    |
| 20. 2.71%                    | 40. 9.81 mi/hr          |



## **Section 3**

### **Circumference, Area, and Volume**

# CIRCUMFERENCE AND AREA

Applied Math for Distribution Systems



## Suggested Strategy to Solving Word Problems

- Disregarding all numbers, what is it asking you to find?
- What diagram, if any, is associated with the concept identified?
- What information is required to solve the problem and how is it expressed in the problem?
  - Create Table of Data
- Use the Table of Data to determine correct formula(s).
- What is the final answer?
  - Make sure units are correct
- Does the answer make sense?

## Parts of a Circle

- Diameter is distance across the center of circle
- Radius is distance from circle's center to the edge
- Circumference is the distance around a circle or a circular object

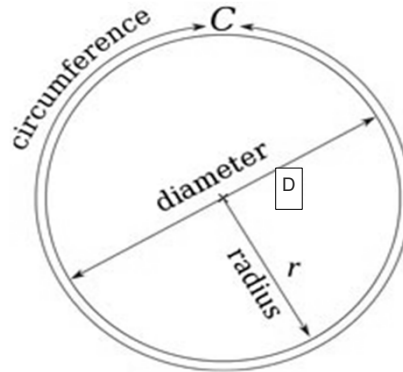

$$r = \left(\frac{1}{2}\right)D$$

## Circumference of a Circle

$$\text{Circumference} = (3.14)(\text{Diameter})$$

### Example 1

- Find the circumference (in inches) of a 6-inch diameter pipe.

$$\text{Circumference} = (3.14)(\text{diameter})$$

$$C = (3.14)(6 \text{ inches})$$

$$C = 18.84 \text{ inches}$$

## Area

- Area is the measurement of the amount of space on the surface of an object
- Two-dimensional measurement
- Measured in: in<sup>2</sup>, ft<sup>2</sup>, acres, etc.

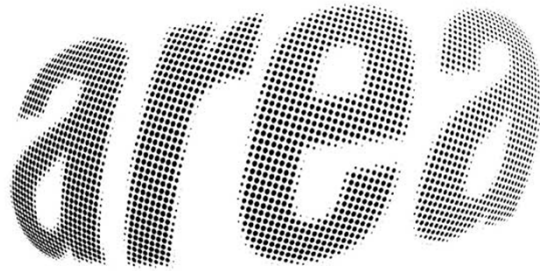

## Area

- Area of Rectangle

$$\text{Area} = (\text{length})(\text{width})$$

$$A = (L)(W)$$

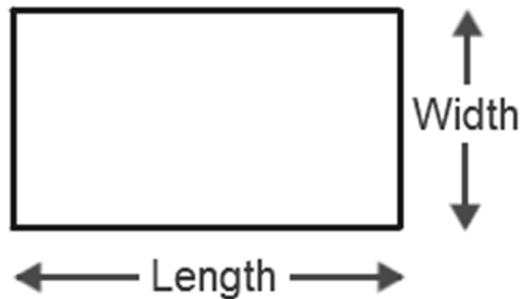



## Example 2

- Find the area in ft<sup>2</sup> of the top of a rectangular basin that is 20 feet long and 17 feet wide.

$$A = (L)(W)$$

$$A = (20\text{ft})(17\text{ft})$$

$$A = 340\text{ft}^2$$

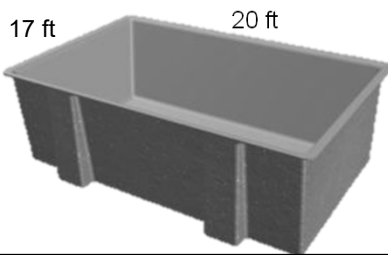

## Area

- Area of Circle

$$\text{Area} = (0.785) (\text{Diameter})^2$$

$$A = (0.785)(D)^2$$

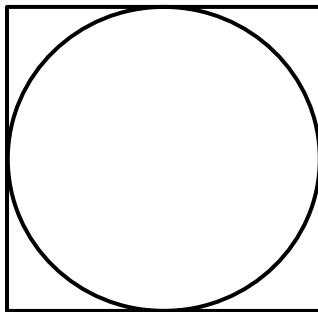

A circle takes up  
78.5% of a square.

## Example 3

- Find the area of the cross section of a pipe in ft<sup>2</sup> that has a diameter of 2 feet.

$$\text{Area} = (0.785)(D)^2$$

$$A = (0.785)(2\text{ft})(2\text{ft})$$

$$A = 3.14 \text{ ft}^2$$

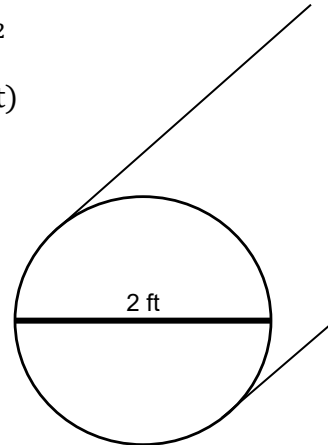
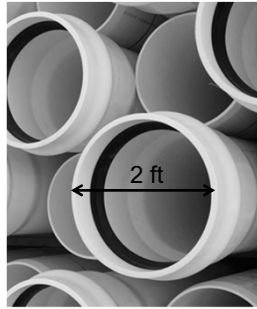

## Area

- Area of Right Triangle

$$\text{Area} = \frac{(\text{base})(\text{height})}{2}$$

$$A = \frac{(b)(h)}{2}$$

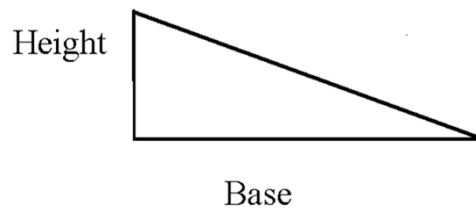

## Example 4

- Determine the area in  $\text{ft}^2$  of a right triangle where the base is 23 feet long with a height of 16 feet.

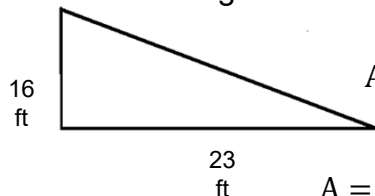

$$A = \frac{(b)(h)}{2}$$

$$A = \frac{(23 \text{ ft})(16 \text{ ft})}{2}$$

$$A = \frac{368 \text{ ft}^2}{2}$$

$$A = 184 \text{ ft}^2$$

## Area

- Area of Cylinder (total exterior surface area)

$$\begin{aligned} \text{Area} &= [\text{surface area of end \#1}] + [\text{surface area of end \#2}] \\ &+ [(3.14)(\text{Diameter})(\text{height})] \end{aligned}$$

$$A = A_1 + A_2 + [(3.14)(D)(h)]$$

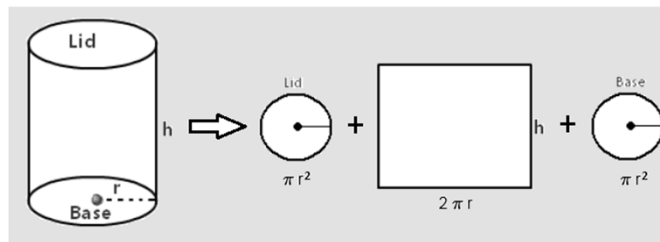

## Example 5

- Find the total exterior surface area in  $\text{ft}^2$  of a barrel that is 3 ft in diameter and 5 feet tall.



$$A = A_1 + A_2 + [(3.14)(D)(h)]$$

$$A_1 = (0.785)(D)^2$$

$$A_1 = (0.785)(3 \text{ ft})(3 \text{ ft})$$

$$A_1 = 3.14 \text{ ft}^2$$

$$A_1 = A_2$$

$$A = 3.14 \text{ ft}^2 + 3.14 \text{ ft}^2 + [(3.14)(3 \text{ ft})(5 \text{ ft})]$$

$$A = 3.14 \text{ ft}^2 + 3.14 \text{ ft}^2 + 47.1 \text{ ft}^2$$

$$A = 53.38 \text{ ft}^2$$

Volume

## Volume

- Volume is the capacity of a unit or how much it will hold
- Measured in
  - cubic units ( $\text{ft}^3$ ,  $\text{m}^3$ ,  $\text{yd}^3$ ) or
  - liquid volume units (gallons, liters, million gallons)
- The answer will come out in cubic units
  - You must then convert it to liquid volume units



## Volume of a Rectangle

$$\text{Volume} = (\text{length})(\text{width})(\text{height})$$

$$\text{Vol} = (l)(w)(h)$$

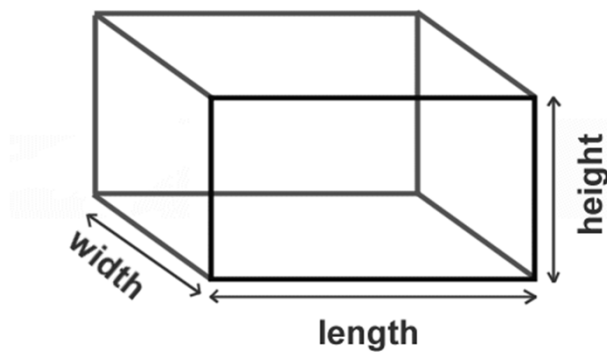

## Example 1

- Determine the volume in  $m^3$  for a tank that measures 3 meters by 4 meters by 2 meters.

$$\text{Vol} = (l)(w)(h)$$

$$\text{Vol} = (3m)(4m)(2m)$$

$$\text{Vol} = 24 m^3$$

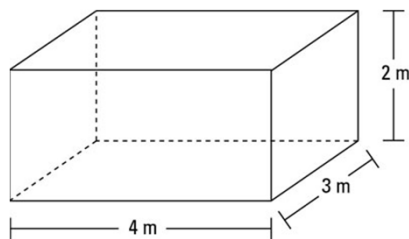

## Volume of a Cylinder

$$\text{Volume} = (0.785)(\text{Diameter})^2(\text{height})$$

$$\text{Vol} = (0.785)(D)^2(h)$$

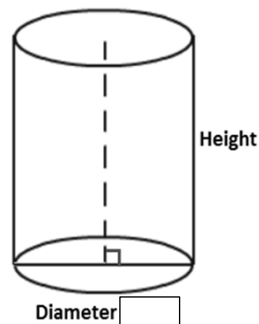

## Example 2

- Determine the volume in  $\text{ft}^3$  for a tank that is 20 feet tall with a diameter of 7.5 ft.

$$\text{Vol} = (0.785)(D)^2(h)$$

$$\text{Vol} = (0.785)(7.5\text{ft})(7.5\text{ft})(20\text{ft})$$

$$\text{Vol} = 883.13 \text{ ft}^3$$



## Volume of a Cone

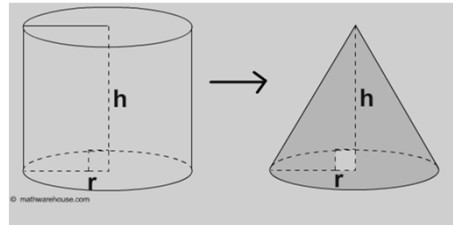

$$\text{Volume} = \left(\frac{1}{3}\right)(0.785)(\text{Diameter})^2(\text{height})$$

$$\text{Vol} = \left(\frac{1}{3}\right)(0.785)(D)^2(h)$$

### Example 3

- Determine the volume in gallons of a conical tank that is 8 feet wide and 15 feet tall.

$$\text{Vol} = \left(\frac{1}{3}\right)(0.785)(D^2)(h)$$

$$\text{Vol} = \left(\frac{1}{3}\right)(0.785)(8\text{ft})(8\text{ft})(15\text{ft})$$

$$\text{Vol} = (0.3333)(753.6 \text{ ft}^3)$$

$$\text{Vol} = 251.1749 \text{ ft}^3$$

$$\text{Vol, gal} = \left(\frac{251.1749 \cancel{\text{ft}^3}}{1}\right) \left(\frac{7.48 \text{ gal}}{1 \cancel{\text{ft}^3}}\right)$$

$$\text{Vol, gal} = 1,878.78 \text{ gallons}$$

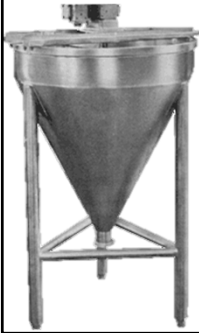



## Math Problem Strategies

Strategy for solving word problems:

- 1) Read the problem, disregard the numbers (What type of problem is it? What am I asked to find?)
- 2) Refer to the diagram, if provided. If there isn't one, draw your own.
- 3) What information do I need to solve the problem, and how is it given in the statement of the problem?
- 4) Work it out.
- 5) Does it make sense?

It might be helpful to write out everything that is known in one column and the unknown (what am I asked to find?) in another column. Identify the correct formula and write it in the middle, plug in the numbers and solve.

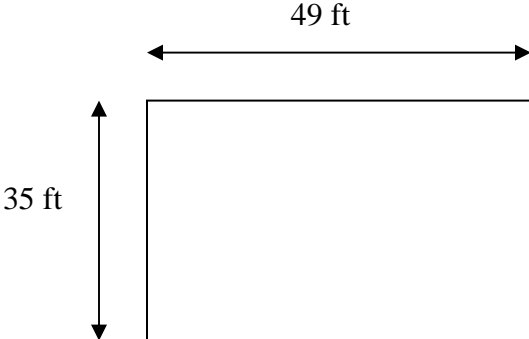
<u>Known</u>		<u>Unknown</u>
Length = 35 ft Width = 49 ft	$A = (l)(w)$  $A = (35 \text{ ft})(49 \text{ ft})$ $A = 1715 \text{ ft}^2$	Area = ?  <div style="text-align: center;">  <p style="margin: 0;">A rectangle is shown with a horizontal dimension of 49 ft and a vertical dimension of 35 ft. The 49 ft dimension is indicated by a double-headed arrow above the rectangle, and the 35 ft dimension is indicated by a double-headed arrow to the left of the rectangle.</p> </div>

**\*\*Remember: make sure measurements agree; if diameter of pipe is in inches then change to feet; if flow is in MGD and you need feet or feet/sec then change to ft<sup>3</sup>/sec before you plug values into formula.**

	..								..	
mega (M)		kilo (k)	hecto (h)	deka (da)	no prefix	deci (d)	centi (c)	milli (m)		micro (μ)
1,000,000		1,000	100	10	1	1/10	1/100	1/1,000		1/1,000,000

Tank Volume Calculations: Most tank volumes calculations are for tanks that are either rectangular or cylindrical in shape.

**Rectangular Tank**

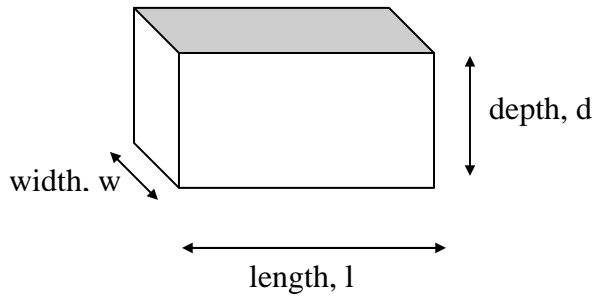

$$\text{Volume} = (l)(w)(d)$$

**Cylindrical Tank**

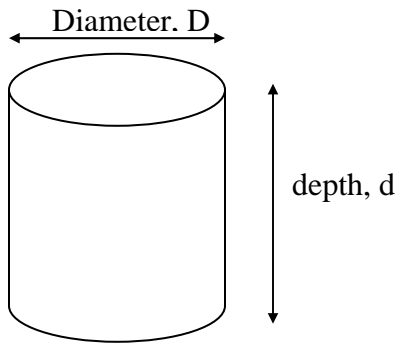

$$\text{Volume} = (0.785)(D)^2(d)$$

**Portion of a Pipeline**

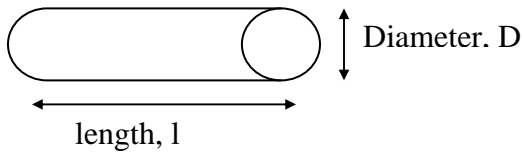

$$\text{Volume} = (0.785)(D)^2(l)$$





**Applied Math for Distribution Systems**  
**Circumference, Area, and Volume**  
**Practice Problems**

Circumference

1. What is the circumference of a tank that is 110.0 ft in diameter?
  
  
  
  
  
  
  
  
  
  
2. The radius of a circular concrete area is 42.5 ft. What is the circumference?

Area

3. What is the area (in ft<sup>2</sup>) of a rectangle 5 ft by 4 ft?
  
  
  
  
  
  
  
  
  
  
4. A rectangle has a length of 5 feet and a width of 3 feet. What is the area (in ft<sup>2</sup>) of the rectangle?
  
  
  
  
  
  
  
  
  
  
5. The diameter of a circle is 5 feet. What is its area (in ft<sup>2</sup>)?
  
  
  
  
  
  
  
  
  
  
6. What is the cross-sectional area (in ft<sup>2</sup>) of a pipe with a diameter of 7 inches?

Volume

7. The dimensions of a tank are 60 feet wide, 10 feet deep and 15 feet long. Calculate the volume of the tank in cubic feet.
  
  
  
  
  
  
  
  
  
  
8. A square tank is 25 ft wide, 75 ft long and can hold water to a depth of 10 ft. What is the volume of the tank, in gallons?
  
  
  
  
  
  
  
  
  
  
9. The diameter of a tank is 60 ft. When the water depth is 25 ft, what is the volume of the water in the tank, in  $\text{ft}^3$ ?

Miscellaneous Questions

10. A rectangular basin has a length of 45 feet and a width of 12 feet. Calculate the area in  $\text{ft}^2$ .
  
  
  
  
  
  
  
  
  
  
11. Calculate the cross-sectional surface area (in  $\text{ft}^2$ ) of rectangular basin which is 90 feet long, 25 feet wide, and 10 feet deep.
  
  
  
  
  
  
  
  
  
  
12. Calculate the volume (in gallons) for a rectangular basin that measures 22 feet by 11 feet by 5 feet.



18. A new water main needs to be disinfected. The main is 30" in diameter and has a length of 0.25 miles. How many gallons of water will it hold?
  
  
  
  
  
  
  
  
  
  
19. A 3 MG water tank needs to be disinfected. The method you will use requires you to calculate 5% of the tank volume. How many gallons will this be?
  
  
  
  
  
  
  
  
  
  
20. Find the area in square feet for a rectangular shaped basin that is 392 ft in length and 71.5 ft wide.
  
  
  
  
  
  
  
  
  
  
21. Find the area of a cylindrical tank if the tank's diameter is 30.4 ft.
  
  
  
  
  
  
  
  
  
  
22. What is the volume of a trench in cubic feet if it is 245 ft in length, 4.2 ft in width, and 5.8 ft in depth?
  
  
  
  
  
  
  
  
  
  
23. What is the capacity of a round tank in cubic feet if it has a diameter of 75.2 ft and the height is 42.3 ft from the base?



24. How many liters of zinc orthophosphate can be contained in a tank that has a diameter of 10.5 ft and can be filled to a height of 9.0 ft?
25. A triangle has a height of 71 feet and a base of 22 feet. What is its area in square feet?
26. If a trench is 346 ft long, 4.4 ft wide, and 5.7 ft deep, how many cubic yards of soil were excavated?
27. A trench that is 156 ft long, 3.8 ft wide and 5.8 ft deep fills with water. How many gallons are contained in the trench?
28. A small circular tank has a diameter of 2.3 ft and a liquid chemical level of 3.6 ft. How many gallons of liquid chemical are contained in the tank?
29. What is the square foot area of a trench that is 68 ft long and 4.5 ft wide?

30. What is the capacity of a round tank in gallons if the diameter is 80.0 ft and the overflow is 32 ft from the base?
  
  
  
  
  
  
  
  
  
  
31. What is the cross-sectional area, in  $\text{ft}^2$ , of a pipe that is 14 inches in diameter?
  
  
  
  
  
  
  
  
  
  
32. A pipe is 7.26 miles long and has an inner diameter of 24 inches. How many gallons can fit in the pipeline?
  
  
  
  
  
  
  
  
  
  
33. What is the exterior surface area in square feet of a cylindrical tank that is 18.0 ft high and 112.0 ft in diameter? Assume the tank is on the ground and the top is flat.
  
  
  
  
  
  
  
  
  
  
34. How many liters are contained in 45 gal of water?

35. What is the volume of a trench in cubic feet if the trench is 24 ft by 3.0 ft by 6.0 ft?
36. What is the volume of a rectangular reservoir in gallons if it is 145 ft long, 76 ft wide, and averages 12 feet in depth?
37. A trench for a water main has to be 675 ft long, 4 ft wide, and 6 ft deep. How many cubic yards must be excavated?
38. What is the square foot area of a triangular concrete slab that has a height of 12 ft and a base of 16 ft?
39. What is the external surface area of an elevated tank if it is 50 ft in diameter and 12 ft high? Assume the top and the bottom are flat.

40. If a circular tank covers an area of  $1,962.5 \text{ ft}^2$ , what is the diameter of the tank?
41. What is the exposed exterior surface area ( $\text{ft}^2$ ) of a ground-level storage tank in square feet that is 16.25 ft high and has a diameter of 125 ft? Assume the top of the tank is flat.
42. If the area of a triangle is  $24 \text{ ft}^2$  and the base is 8 ft, what is the height of the triangle in feet?
43. Find the volume in gallons for a storage tank that is 18 ft in height and has a circumference of 215.8 ft.
44. A storage tank is 110 ft in diameter and has an overflow of 34.5 ft above the base of the tank. How many gallons of water are in the tank if it is 72.4% full?

45. A trench that averages 3.5 ft wide and 4.0 ft in depth is dug for the purpose of installing a 24-inch diameter pipeline. If the trench is 1,663 ft long, how much soil, in cubic feet, will be put in the trench after pipe is in place, assuming that the only soil left over is that which the pipe now occupies?
46. The circumference of a tank is 188.5 ft. What is the top of the tank's surface area, in  $\text{ft}^2$ ?
47. A distribution pipe is 2.32 miles long. What is the volume of water in gallons if the pipe is 2.0 ft in diameter for a length of 1.75 mile and 18 inches for the remainder?
48. A tank is conical at the bottom and cylindrical at the top. If the diameter of the cylinder is 12.0 ft with a depth of 20.0 ft and the cone depth is 12.0 ft, what is the volume of the tank in cubic feet?

49. Determine the volume of water in gallons for the following distribution system:

Distribution pipe A is 985 ft in length and 3.0 ft in diameter

Distribution pipe B is 645 ft in length and 2.0 ft in diameter

The storage tank is 110 ft in diameter and has a water height of 25.36 ft.

50. If you double the size of a pipe, does it double the volume that can be carried? For example, if you have 1000 feet of 12-inch line and you replace it with a 24-inch line, does your volume double?

**Answers**

1.)	26.)
2.)	27.)
3.)	28.)
4.)	29.)
5.)	30.)
6.)	31.)
7.)	32.)
8.)	33.)
9.)	34.)
10.)	35.)
11.)	36.)
12.)	37.)
13.)	38.)
14.)	39.)
15.)	40.)
16.)	41.)
17.)	42.)
18.)	43.)
19.)	44.)
20.)	45.)
21.)	46.)
22.)	47.)
23.)	48.)
24.)	49.)
25.)	50.)

## Applied Math for Distribution Systems

### Area and Volume

### Extra Problems

1. Find the area in square feet for a rectangular shaped sedimentation basin that is 392 ft in length and 71.5 ft in width.
2. What is the cross sectional area, in  $\text{ft}^2$ , of a tank if the tank's diameter is 30.4 feet?
3. A chemical holding tank has a diameter of 19 feet. What is the circumference of the tank in feet?
4. A tank is 60 feet long, 15 feet wide, and 10 feet deep. What is the area of the top of the tank in  $\text{ft}^2$ ?
5. An oxidation ditch is 50 feet long, 30 feet deep and 20 feet wide. How many gallons of water can the ditch hold?
6. A basin is 12 ft by 22 ft. What is the surface area in  $\text{ft}^2$ ?



7. A filter basin is 50 ft wide, 20 ft long and 15 feet deep. During a hook gage test, the water level dropped 6 inches. How many gallons of water were filtered?
  
  
  
  
  
  
  
  
  
  
8. Calculate the lateral surface area (in  $\text{ft}^2$ ) of a cone shaped hopper with a diameter of 3 feet and a height of 9 feet.
  
  
  
  
  
  
  
  
  
  
9. A new 12 inch main must be installed. The total amount of pipe needed will be 5280 feet. What is the cross-sectional areal in  $\text{ft}^2$ ?
  
  
  
  
  
  
  
  
  
  
10. What is the surface area ( $\text{ft}^2$ ) of a rectangular settling basin 60 ft long by 15 ft wide?
  
  
  
  
  
  
  
  
  
  
11. What is the volume of a tank in gallons that is 5'8" wide, 9'7" long, and 3'1" deep?
  
  
  
  
  
  
  
  
  
  
12. What is the cross-sectional area in  $\text{ft}^2$  of a pipe that is 14 inches in diameter?

13. A new 8 inch main must be laid for 1.5 miles. What is the total number of gallons of water to be disinfected?
14. A chemical hopper is cone shaped and covered. It has a diameter of 7 feet and a depth of 13 feet. Calculate the total surface area of the hopper (in ft<sup>2</sup>).
15. A section of 6 inch diameter pipeline is to be filled with chlorinated water for disinfection. If a 1/4 mile of pipeline is to be disinfected, how many gallons of water will be required to fill the pipe completely?
16. A reservoir is found to average 56 ft in depth. The shape of the lake is approximately circular with a diameter of approximately 570 ft. How many acre-feet of water does the lake contain?
17. How many liters of chemical can be contained in a tank that has a diameter of 10.5 feet and can be filled to a height of 9.0 feet?

18. What is the total surface area in  $\text{ft}^2$  for a 16 inch main that is 1250 feet long?
19. A new section of 12 inch diameter pipe is to be disinfected before it is put into service. If the length of the pipeline is 2000 ft, how many gallons of water will be needed to fill the pipeline?
20. If a trench is 346 ft long, 4.4 ft wide, and 5.7 ft deep, how many cubic yards of soil were excavated?
21. The diameter of a tank is 60 ft. When the water depth is 25 feet, what is the volume of water in the tank, in  $\text{ft}^3$ ?
22. Calculate the volume (in  $\text{ft}^3$ ) of a cone shaped chemical hopper with a diameter of 12 feet and a depth of 18 feet.
23. An aeration basin is 45 feet by 45 feet and is 30 feet deep. What is the total volume of water, in cubic feet, that the basin can hold?

24. A trench is to be excavated 2.5 feet wide, 4 feet deep and 900 feet long. What is the cubic yards volume of the trench?
25. A pipe is 16 inches in diameter and 550 ft long. How many gallons does the pipe contain when full?
26. A 1500 ft 10 inch diameter main flows full. How many gallons of water are contained in that section of line?
27. A trench that is 156 ft long, 3.8 ft wide and 5.8 ft deep fills with water. How many gallons are contained in the trench?
28. A tank is 12 ft wide, 20 ft long and 15 ft deep. If the depth of the water is 11 feet, what is the volume of water in the tank in gallons?
29. What is the volume of a trench in cubic feet if it is 245 ft in length, 4.2 feet in width and 5.8 ft deep?
30. A tank is 25 ft wide, 75 ft long, and can hold water to a depth of 10 ft. What is the total volume of the tank, in gallons?

31. Calculate the volume, in cubic feet, of a circular clarifier 7 ft deep and 40 ft in diameter.

32. What is a tank's diameter if the surface area is 6720 ft<sup>2</sup>?

33. Calculate the volume of an aeration basin, in gallons, that has the following dimensions: 10 ft high, 60 ft long, 20 ft wide.

34. What is the cubic yard volume of a trench 500 ft long, 2.25 ft wide and 4 feet deep?

35. a. A circular water tower that is tapered at the bottom has a diameter of 40 feet and a height of 75 feet from the top to the beginning of the taper. The cone created by the taper has a height of 20 feet. Calculate the total exterior surface area of the water tower.

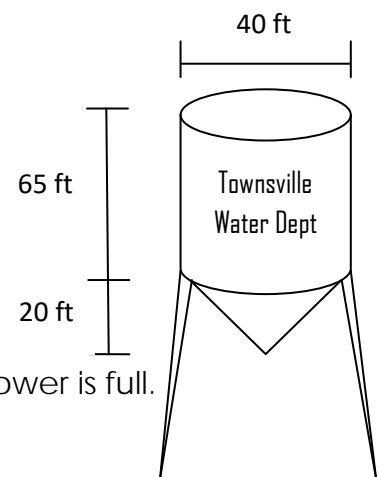

35 b. Calculate the total volume (in gallons) when the tower is full.

**Area and Volume Answers:**

- |     |                        |       |                           |
|-----|------------------------|-------|---------------------------|
| 1)  | 28,028 ft <sup>2</sup> | 24)   | 333.3 yd <sup>3</sup>     |
| 2)  | 725.47 ft <sup>2</sup> | 25)   | 5,741.03 gal              |
| 3)  | 59.66 ft               | 26)   | 6,115.97 gal              |
| 4)  | 900 ft <sup>2</sup>    | 27)   | 25,718.04 gal             |
| 5)  | 224,400 gal            | 28)   | 19,747.2 gal              |
| 6)  | 264 ft <sup>2</sup>    | 29)   | 5,968.2 ft <sup>3</sup>   |
| 7)  | 3,740 gal              | 30)   | 140,250 gal               |
| 8)  | 43.06 ft <sup>2</sup>  | 31)   | 8,792 ft <sup>3</sup>     |
| 9)  | 0.79 ft <sup>2</sup>   | 32)   | 92.52 ft                  |
| 10) | 1,500 ft <sup>2</sup>  | 33)   | 89,760 gal                |
| 11) | 1,252.46 gal           | 34)   | 166.67 yd <sup>3</sup>    |
| 12) | 1.07 ft <sup>2</sup>   | 35)a. | 11,196.25 ft <sup>2</sup> |
| 13) | 20,670.8 gal           | b.    | 673,299.73 gal            |
| 14) | 186.42 ft <sup>2</sup> |       |                           |
| 15) | 193,769.4 gal          |       |                           |
| 16) | 327.71 ac-ft           |       |                           |
| 17) | 22,052.52 L            |       |                           |
| 18) | 1.4 ft <sup>2</sup>    |       |                           |
| 19) | 11,743.6 gal           |       |                           |
| 20) | 321.4 yd <sup>3</sup>  |       |                           |
| 21) | 70,650 ft <sup>3</sup> |       |                           |
| 22) | 678.24 ft <sup>3</sup> |       |                           |
| 23) | 60,750 ft <sup>3</sup> |       |                           |

## **Section 4**

### **Flow and Velocity**

# Velocity & Flow

Applied Math for Distribution Systems

## Velocity

- The speed at which something is moving
- Measured in

○ ft/min   ft/sec   miles/hr   etc

$$\text{Velocity} = \frac{\text{distance}}{\text{time}}$$



## Example 1

- Blue dye is placed in a sewer line at a manhole. Three (3) minutes later, the dye appears in a manhole 125 feet down stream. What is the velocity of the flow in ft/min?

$$\text{Velocity} = \frac{\text{distance}}{\text{time}}$$

$$\text{Vel} = \frac{125 \text{ ft}}{3 \text{ min}}$$

$$\text{Vel} = 41.67 \text{ ft/min}$$

## Flow

- The volume of water that flows over a period of time
  - $\frac{\text{volume}}{\text{time}}$
- Measured in
  - $\text{ft}^3/\text{sec}$     $\text{ft}^3/\text{min}$     $\text{gal}/\text{day}$    MGD

$$\text{Flow} = (\text{Area})(\text{Velocity})$$

$$Q = AV$$

## Example 2

- Water is flowing at velocity 3 ft/sec through a channel that is 2 feet wide and 1.5 inches deep. What is the flow in cubic feet per second?

$$\text{Flow} = (\text{area, ft}^2)(\text{velocity})$$

$$A = (L)(W) \quad \text{Flow} = (L)(W)(\text{velocity})$$

$$\text{Flow} = (2\text{ft})(1.5\text{ft})(3 \text{ ft}/\text{sec})$$

$$\text{Flow} = 9 \text{ ft}^3/\text{sec}$$

## Example 3

- Determine the flow in ft<sup>3</sup>/sec through a 5 foot pipe that is flowing full at a velocity of 4.5 ft/sec.

$$Q = (\text{area})(\text{velocity}) \quad A = (0.785)(D)^2$$

$$Q = (0.785)(D)^2(\text{vel})$$

$$Q = (0.785)(5\text{ft})(5\text{ft})(4.5 \text{ ft}/\text{sec})$$

$$Q = 88.3 \text{ ft}^3/\text{sec}$$



## Applied Math for Water Treatment Flow and Velocity

### Velocity

1. A cork is placed in a channel and travels 370 feet in 2 minutes. What is the velocity of the wastewater in the channel, ft/min?
  
2. A float travels 300 feet in a channel in 2 minutes and 14 seconds. What is the velocity in the channel, ft/sec?
  
3. The distance between manhole #1 and manhole #2 is 105 feet. A fishing bobber is dropped into manhole #1 and enters manhole #2 in 30 seconds. What is the velocity of the wastewater in the sewer in ft/min?

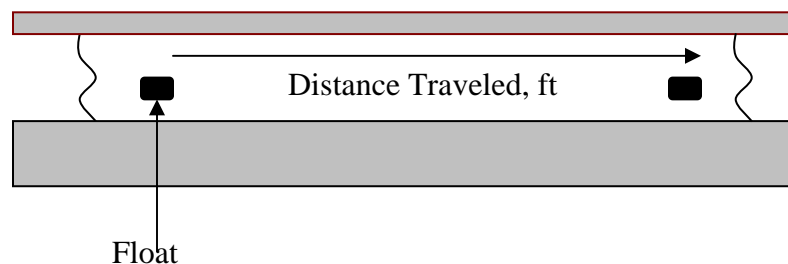

$$\text{Velocity} = \frac{\text{Distance Traveled, ft}}{\text{Duration of Test, min}}$$

$$= \text{ft/min}$$

3.) 210 ft/min

2.) 2.2 ft/sec

1.) 185 ft/min

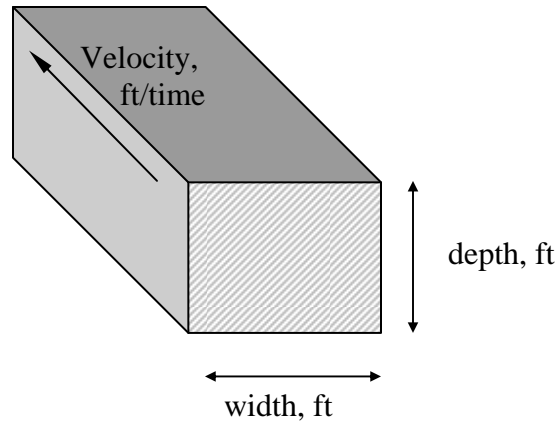

$$Q = (A) (V)$$

$$\text{ft}^3/\text{time} = (\text{ft})(\text{ft}) (\text{ft}/\text{time})$$

#### Flow in a channel

4. A channel 48 inches wide has water flowing to a depth of 1.5 feet. If the velocity of the water is 2.8 ft/sec, what is the flow in the channel in cu ft/sec?
  
5. A channel 3 feet wide has water flowing to a depth of 2.5 feet. If the velocity through the channel is 120 feet/min, what is the flow rate in cu ft/min? in MGD?
  
6. A channel is 3 feet wide and has water flowing at a velocity of 1.5 ft/sec. If the flow through the channel is 8.1 ft<sup>3</sup>/sec, what is the depth of the water in the channel in feet?

6.) 1.8 ft

5.) 900ft<sup>3</sup>/min; 9.7 MGD4.) 16.8 ft<sup>3</sup>/sec

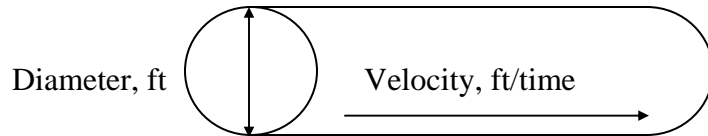

$$Q = (A) (V)$$

$$\text{ft}^3/\text{time} = \text{ft}^2 (\text{ft}/\text{time})$$

$$Q = (0.785) (D)^2 (\text{vel})$$

$$\text{ft}^3/\text{time} = (\text{ft})(\text{ft}) (\text{ft}/\text{time})$$

Flow through a full pipe

7. The flow through a 2 ft diameter pipeline is moving at a velocity of 3.2 ft/sec. What is the flow rate in cu ft/sec?
  
8. The flow through a 6 inch diameter pipeline is moving at a velocity of 3 ft/sec. What is the flow rate in ft<sup>3</sup>/sec?
  
9. The flow through a pipe is 0.7 ft<sup>3</sup>/sec. If the velocity of the flow is 3.6 ft/sec, and the pipe is flowing full, what is the diameter of the pipe in inches?
  
10. An 8 inch diameter pipeline has water flowing at a velocity of 3.4 ft/sec. What is the flow rate in gpm?

10.) 532.4 gpm

9.) 6 in

8.) 0.59 ft<sup>3</sup>/sec

7.) 10.05 ft<sup>3</sup>/sec

## APPLIED MATH FOR WATER FLOW RATE

$$Q = AV$$

1. A channel is 3 feet wide with water flowing to a depth of 2 feet. If the velocity in the channel is found to be 1.8 fps, what is the cubic feet per second flow rate in the channel?
2. A 12-inch diameter pipe is flowing full. What is the cubic feet per minute flow rate in the pipe if the velocity is 110 feet/min?
3. A water main with a diameter of 18 inches is determined to have a velocity of 182 feet per minute. What is the flow rate in gpm?
4. A 24-inch main has a velocity of 212 feet/min. What is the gpd flow rate for the pipe?





9. A water crew is flushing hydrants on a 12-inch diameter main. The pitot gage reads 560 gpm being flushed from the hydrant. What is the flushing velocity (in feet/min) through the pipe?

#### VELOCITY (OPEN CHANNEL)

10. A float is placed in a channel. It takes 2.5 minutes to travel 300 feet. What is the flow velocity in feet per minute in the channel? (Assume that float is traveling at the average velocity of the water.)
11. A cork placed in a channel travels 30 feet in 20 seconds. What is the velocity of the cork in feet per second?
12. A channel is 4 feet wide with water flowing to a depth of 2.3 feet. If a float placed in the channel takes 3 minutes to travel a distance of 500 feet, what is the cubic-feet-per-minute flow rate in the channel?

**AQUIFER FLOW**

13. Geologic studies show that the water in an aquifer moves 25 feet in 60 days. What is the average velocity of the water in ft/day?
  
  
  
  
  
  
  
  
  
  
14. If the water in a water table aquifer moves 2 feet per day, how far will the water travel in 13 days?
  
  
  
  
  
  
  
  
  
  
15. If the water in a water table aquifer moves 2.25 feet per day, how long will it take the water to move 61 feet?

**FLOW**

16. The average velocity in a full-flowing pipe is measured and known to be 2.9 fps. The pipe is a 24" main. Assuming that the pipe flows 18 hours per day and that the month in question contains 31 days, what is the total flow for the pipe in MG for that one month?

17. The flow entering the leg of a tee connection is 9 cfs. If the flow through one branch of the tee is 5 cfs, what is the flow through the other branch?

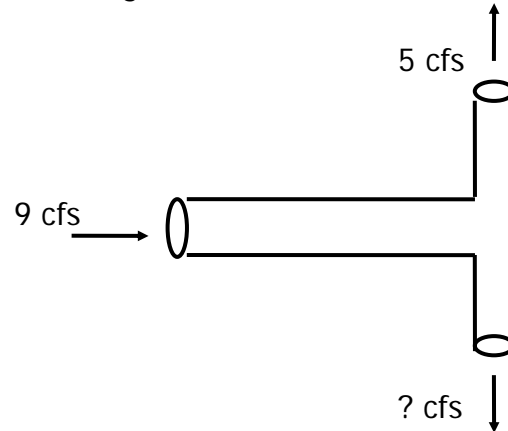

18. A water line has been run to a new subdivision. The flow through the main line is 468 gpm. The line splits into two lines (each serving half of the subdivision). If one line flows 210 gpm, what should be the flow from the other line?

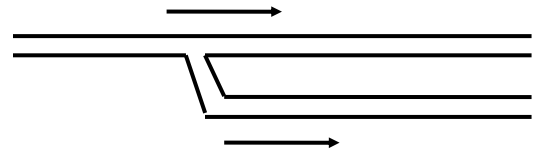

19. Determine the velocity in ft/sec at points A, B, & C.

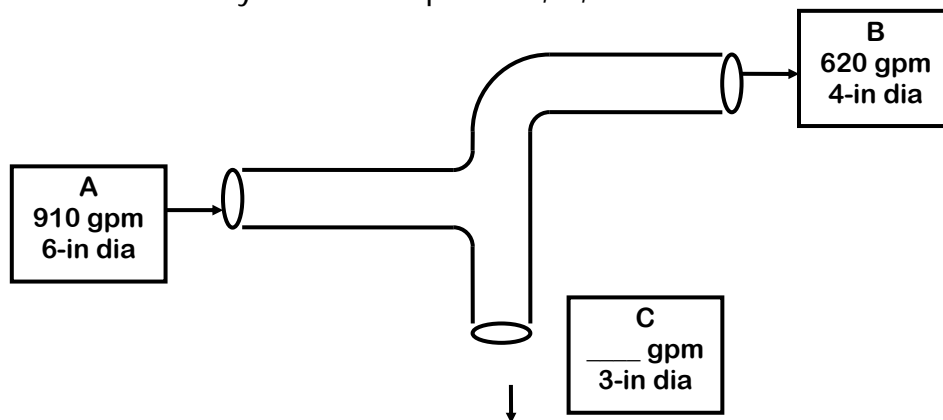

## ANSWERS:

1. 10.8 ft<sup>3</sup>/sec
2. 86.35 ft<sup>3</sup>/min
3. 2,404.50 gpm
4. 7,170,172.42 gpd
5. 253,661.76 gpd
6. 7,926.93 gpm
7. 9.13 MGD
8. 9.47 MGD
9. 95.37 ft/min
10. 120 ft/min
11. 1.5 ft/sec
12. 1,533.3 ft<sup>3</sup>/min
13. 0.42 ft/day
14. 26 ft
15. 27.11 days
16. 136.83 MG
17. 4 ft<sup>3</sup>/sec
18. 258 gpm
19. A. 10.33 ft/sec  
B. 15.84 ft/sec  
C. 13.17 ft/sec

## Applied Math for Distribution Systems

### Velocity and Flow Problems

1. What is the velocity of flow in feet per second for a 10 inch diameter pipe if it delivers 740 gpm?
2. What is the velocity of flow in feet per second for a 6 inch diameter pipe if it delivers 350 gpm?
3. Water is flowing in a pipeline at  $2.65 \text{ ft}^3/\text{sec}$ . What is the flow in gallons per minute?
4. A water hydrant is flowing 285 gpm. How many cubic feet per second is this?
5. A meter indicates water is flowing from a fire hydrant at  $1.50 \text{ ft}^3/\text{min}$ . How many gallons will flow from the hydrant if it is flushed for exactly 30 min?



12. A water tank with a capacity of 1.2 MG is being filled at a range of 2,140 gpm. How many hours will it take to fill the tank?
  
  
  
  
  
  
  
  
  
  
13. An 8.0 inch diameter distribution pipe delivers 1,011,000 gallons in 24 hours. What is the average velocity during the 24 hour time period in feet per second?
  
  
  
  
  
  
  
  
  
  
14. A water channel is 8.25 ft wide and averages 3.75 ft in depth. What is the velocity of the water (ft/sec) if the flow is 45 ft<sup>3</sup>/sec?
  
  
  
  
  
  
  
  
  
  
15. The velocity through a channel is 2.10 ft/sec. If the channel is 6.5 ft wide and 2.8 ft in depth, what is the flow in cubic feet per second?
  
  
  
  
  
  
  
  
  
  
16. Water is flowing through a faucet at 15.5 gpm. How long will it take to fill a swimming in hours and minutes if the pool is 45 ft by 22 ft and averages 5.5 ft in depth?

17. If a 5 gallon bucket is filled in 17 seconds, what is the flow from the faucet in gallons per minute?
18. What should the flow meter read in gallons per minute if a 12 inch diameter main is to be flushed at 4.9 ft/sec?
19. What should the flow meter read in gallons per minute if an 18 in. diameter main is to be flushed at 4.75 ft/sec?
20. If a pump discharges 8,240 gal in 1 hour, what will it discharge in 15 hr and 15 min?
21. The velocity through a channel is 1.88 ft/sec. If the channel is 9.45 ft wide and 3.1 ft deep, what is the flow in cubic feet per second? Assume the channel is basically square.



22. Determine the velocity in feet per second if a water flow of 677 gpm is going through an 8 in. pipe.
23. Water is flowing at a velocity of 2.63 ft/sec in an 8 inch diameter pipe. If the pipe changes from the 8 inch to a 14 inch pipe, what will the velocity be in the 14 inch pipe?
24. What is the velocity in ft/min through a 4 inch diameter pipe if it is delivering 175 gpm?
25. Determine the amount of gallons that were used from a storage tank for a particular day in question, given the flowing data:
- Diameter of the tank = 100.0 ft
  - Initial water level at beginning of day = 32.56 ft
  - Final water level at end of day = 28.33 ft
  - Water pumped to tank = 802 gpm

26. A 12 inch main line needs to be flushed. How many minutes will it take to flush the line at 30 gpm if the desired length of pipeline to be flushed is 200 ft.
27. A 31 ft, 1 inch service line requires flushing. How many minutes are required to flush the line if the line is flushed at a rate of 12 gpm and 25 volumes are removed?
28. A 14 inch main line needs to be flushed. If a 100 ft section of the pipeline was flushed for 28 min, what was the flushing rate in gallons per minute?
29. A distribution pipe that is 36 inches in diameter delivers 17,600,000 gallons in 24 hours. What is the average velocity during the 24 hour time period in feet per second?
30. Water is flowing at a velocity of 3.95 ft/sec in an 6 inch diameter pipe. If the pipe changes from the 6 inch to a 10 inch pipe, what will the velocity be in the 10 inch pipe?

31. Water is flowing at a velocity of 1.28 ft/s in an 14 inch diameter pipe. If the pipe changes from the 14 inch to an 8 inch pipe, what will the velocity be in the 8 inch pipe?

**Answers**

- |                                |                                |
|--------------------------------|--------------------------------|
| 1. 3.03 ft/sec                 | 17. 17.65 gal/min              |
| 2. 3.97 ft/sec                 | 18. 1,726.31 gpm               |
| 3. 1,189.32 gal/min            | 19. 3,765.29 gpm               |
| 4. 0.64 ft <sup>3</sup> /sec   | 20. 125,660 gal                |
| 5. 336.6 gal                   | 21. 55.07 ft <sup>3</sup> /sec |
| 6. 20.41 hr                    | 22. 4.3 4.32 ft/sec            |
| 7. 173.07 min                  | 23. 0.86 ft/sec                |
| 8. 1,029.25 gal                | 24. 268.28 ft/min              |
| 9. 776.42 gpm                  | 25. 1,403,257 gal              |
| 10. 0.55 cfs                   | 26. 39.14 min                  |
| 11. 1570.8 gpm                 | 27. 2.63 min                   |
| 12. 9.35 hr                    | 28. 28.55 gal/min              |
| 13. 4.47 ft/sec                | 29. 3.85 ft/sec                |
| 14. 1.45 ft/sec                | 30. 1.42 ft/sec                |
| 15. 38.22 ft <sup>3</sup> /sec | 31. 3.92 ft/sec                |
| 16. 43 hr 47 min               |                                |



**Section 5**  
**Disinfection**

# Disinfection

## Applied Math for Distribution Systems



# Hypochlorite

- 2 types of hypochlorite used for disinfection in typical drinking water distribution systems
  - Sodium hypochlorite
    - NaOCl
    - Bleach
    - 5-15% concentration
    - liquid
  - Calcium hypochlorite
    - $\text{Ca}(\text{OCl})_2$
    - High test hypochlorite (HTH)
    - 65% concentration
    - solid

## Feed Rate

- When dosing a volume of water, feed rate depends on factors such as the type of chemical being used, the reason for dosing and the flow rate being treated.

$$\text{feed rate, } \frac{\text{lb}}{\text{day}} = \frac{(\text{dose, mg/L})(\text{flow, MGD})(8.34 \text{ lb/gal})}{\% \text{ purity}}$$

## Example 1

- A water system wants to feed calcium hypochlorite with a purity of 65%. The required dose is 8 mg/L to completely disinfect a flow of 3 MGD. How many pounds per day of disinfectant must be fed?

$$\text{feed rate, } \frac{\text{lb}}{\text{day}} = \frac{(\text{dose, mg/L})(\text{flow, MGD})(8.34 \text{ lb/gal})}{\% \text{ purity}}$$

$$\frac{\text{lb}}{\text{day}} = \frac{(8 \text{ mg/L})(3 \text{ MGD})(8.34 \text{ lb/gal})}{0.65}$$

$$\frac{\text{lb}}{\text{day}} = 307.94 \text{ lb/day}$$

## Mass and Loading Rate

- Same as feed rate without the % purity
  - If percent purity of a chemical is not provided, it is assumed to be 100% pure; therefore, the % purity can be omitted

$$\text{mass, lbs} = (\text{volume, MG}) \left( \text{conc., } \frac{\text{mg}}{\text{L}} \right) \left( 8.34 \frac{\text{lb}}{\text{gal}} \right)$$

$$\text{loading rate, } \frac{\text{lb}}{\text{day}} = (\text{flow, MGD}) \left( \text{conc., } \frac{\text{mg}}{\text{L}} \right) \left( 8.34 \frac{\text{lb}}{\text{gal}} \right)$$

## Pounds Formula

<b>lb=</b>	<b>(mg/L)</b>	<b>(MG)</b>	<b>(8.34)</b>
Feed rate=	(Dosage)	(Capacity)	(8.34 lb/gal)

$$\text{Mass} = (\text{Concentration}) (\text{Volume}) (8.34 \text{ lb/gal})$$

$$\text{Loading rate} = (\text{Concentration}) (\text{Flow}) (8.34 \text{ lb/gal})$$

$$\text{lbs} = (\text{dose})(\text{flow})(8.34 \text{ lb/gal})$$



## Chlorination

$$\frac{\text{lb}}{\text{day}} = \frac{(\text{dose, mg/L})(\text{flow, MGD})(8.34 \frac{\text{lb}}{\text{gal}})}{\% \text{ purity}}$$

\*\*If they ask for gpd, convert from lb/day\*\*

$$\left(\frac{\cancel{\text{lb}}}{\text{day}}\right) \left(\frac{1 \text{ gal}}{8.34 \cancel{\text{lb}}}\right) = \frac{\text{gal}}{\text{day}}$$

## Example 2

- A water distribution system feeds 65 lb/day of 65% calcium hypochlorite. If the flow is 1.6 MGD, what dose, in mg/L, of disinfectant will result?

$$\frac{\text{lb}}{\text{day}} = \frac{(\text{dose, mg/L})(\text{flow, MGD})(8.34 \frac{\text{lb}}{\text{gal}})}{\% \text{ purity}}$$

$$65 \text{ lb/day} = \frac{(X)(1.6 \text{ MGD})(8.34)}{0.65}$$

$$\frac{(0.65)(65 \text{ lb/day})}{(1.6 \text{ MGD})(8.34)} = X$$

$$3.17 \text{ mg/L} = X$$

## Two Normal equation

- C = concentration
  - Can be replaced with normality
- V = volume or flow

$$C_1 \times V_1 = C_2 \times V_2$$

want = have

## Example 3

- A distribution operator needs to make 10 gallons of a bleach dilution with a concentration 25 mg/L. The bleach on hand has a concentration of 100 mg/L. How many gallons of the concentrate must be used to achieve the dilution?

$$C_1 \times V_1 = C_2 \times V_2$$

$$(\text{Conc}_{\text{want}})(\text{Vol}_{\text{want}}) = (\text{Conc}_{\text{have}})(\text{Vol}_{\text{have}})$$

$$(25 \text{ mg/L})(10 \text{ gal}) = (100 \text{ mg/L})(V)$$

$$\frac{(25 \text{ mg/L})(10 \text{ gal})}{100 \text{ mg/L}} = V$$

$$2.5 \text{ gal} = V$$

## Breakpoint Chlorination

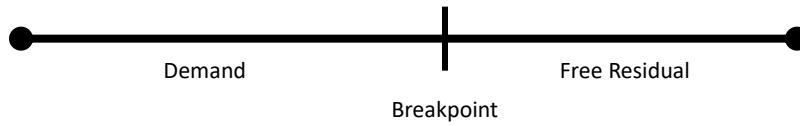

- Total chlorine dose = residual + demand
- Demand = Dose - residual
- Residual = Dose - demand

## Breakpoint Chlorination

- Total chlorine = free residual + combined residual

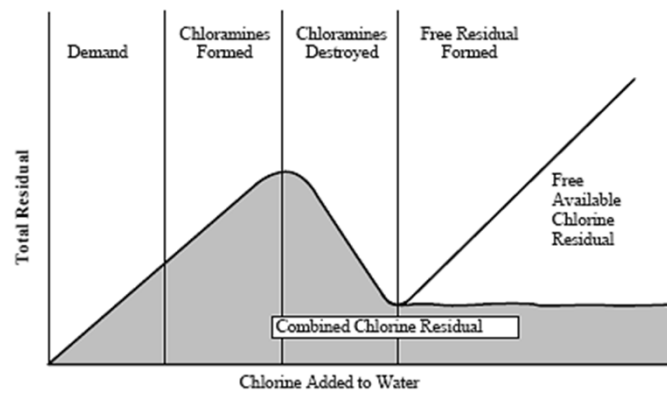

## CT Calculation

$$\text{Kill} = C \times T$$

- Concentration and contact time are two of the most important parameters in chlorination
- They are inversely proportional
  - As one decreases, the other must increase
- CT is simply the concentration of chlorine in your water times the time of contact that the chlorine has with your water
  - Measured in  $\frac{\text{mg}\cdot\text{min}}{\text{L}}$

$$\text{CT} = (\text{disinfectant residual, } \frac{\text{mg}}{\text{L}})(\text{time, min})$$

## Example 4

- Treated water is dosed with 5 mg/L of chlorine for 30 minutes. What is the CT?

$$\text{CT} = (\text{disinfectant residual, } \frac{\text{mg}}{\text{L}})(\text{time, min})$$

$$\text{CT} = (5 \frac{\text{mg}}{\text{L}})(30 \text{ min})$$

$$\text{CT} = 150 \frac{\text{mg}\cdot\text{min}}{\text{L}}$$

## Disinfection

1. Determine the feed rate in lb/day for a system that wants to dose 2.6 mg/L of 65% HTH. The plant averages 150,000 gallons per day.
2. How many gallons per day of 0.08% sodium hypochlorite would a system need to feed to obtain the required dose of 1.9 mg/L if the system treats 2.0 MGD?
3. Calculate the chlorine dose (mg/L) required if the demand of a water source is 3.7 mg/L and the utility wants to maintain a chlorine residual of 0.8 mg/L in the system.
4. A booster chlorination station feeds 90 lbs/day of chlorine gas to disinfect 900,000 gpd. What is the dose in mg/L?



## Applied Math for Distribution Systems Disinfection Practice Problems

### Volume

1. A tank is 60 feet in diameter and has a distance of 90 feet to the overflow. How many million gallons will the tank hold?
2. A tank holds 1.8 million gallons. How many gallons is 5% of the total volume?
3. How many gallons are in a pipe that is 18 inches in diameter and 1,165 feet long?

### Pounds

4. If a storage tank holds 1,000,000 gallons filled to the overflow, and the initial chlorine dose needs to be 15 mg/L, how many pounds of HTH 65% available chlorine will it take to get the required dose?
5. The desired chlorine dosage is 10 mg/L. Determine the lb/day setting on a dry chemical feeder if the flow is 3,450,000 gpd.
6. The required dose for a water sample is 12 mg/L. If the flow to be treated is 1,660,000 gpd, what should the dry chemical feed setting be in lb/day?

7. How many pounds of calcium hypochlorite that contains 64.3% available chlorine are needed to disinfect a water main that is 24 inches in diameter, if the pipeline is 781 ft long and the dosage required is 50 mg/L?

### **Dose**

8. A water treatment plant is treating 16.4 MGD. If the chlorine feed rate is 415 lb/day, what is the chlorine dosage in mg/L?
  
  
  
  
  
  
  
  
  
  
9. What is the chlorine dosage at a water treatment plant, if the chlorinator is set on 320 lb/day and the plant is treating 11.6 MGD?
  
  
  
  
  
  
  
  
  
  
10. A 2 foot diameter pipe that is 2.45 miles long was disinfected with chlorine. If 126.9 lbs of chlorine were used, what was the initial dosage in mg/L?

### **Dilutions/Solutions**

11. How many gallons of bleach (15% available chlorine) will it take to make a 4% solution when added to enough water to make 50 gallons of hypochlorite?



12. How many pounds of HTH (65% available chlorine) will it take to make a 2% solution when dissolved in enough water to make 15 gallons of hypochlorite?

### **Practice Problems**

13. The 50,000 gallon storage tank is disinfected using AWWA Chlorination Method 3 with 50 mg/L using HTH. How many pounds of HTH 65% available chlorine would be required?
14. What is the dosage in milligrams per liter for a treatment plant that uses 855 lb/day of chlorine and treats 45.25 MGD?
15. How many pounds of 65% available HTH is needed to make 5 gallons of 18% solution?
16. How many pounds of 65% available chlorine HTH is needed to make 1 gallon of 10% solution?
17. The chlorine demand of a water process is 1.6 mg/L. If the desired chlorine residual is 0.5 mg/L, what is the desired chlorine dose?

18. The chlorine dosage for a water process is 2.9 mg/L. If the chlorine residual after 30 minutes of contact time is found to be 0.7 mg/L, what is the chlorine demand expressed in mg/L?
19. You have just laid 5,000 feet of 10-inch line and it needs disinfecting. How many lbs of 65% HTH chlorine will be required to dose the line with 25 mg/L? The main can hold approximately 20,400 gallons.
20. A section of an old 8" water main has been replaced. The 350-foot section of pipe needs to be disinfected. What is the volume (in gallons) to be disinfected?
21. You have just laid  $\frac{3}{4}$  mile long section of 16-inch line that holds 41,335 gal, and it needs disinfecting. How many pounds of 65% HTH chlorine will be required to dose the line with 10 mg/L?
22. A flow of 3,880,000 gpd is to be disinfected with liquid chlorine. If the chlorine dosage desired is 3.4 mg/L, what should be the chlorinator setting in lb/day?
23. How many pounds of HTH (65% available chlorine) will it take to make a 2% solution when dissolved in enough water to make 15 gallons of hypochlorite?

24. You have just laid 25,000 feet of 2 ft line and it needs disinfecting. How many lbs of 65% HTH chlorine will be required to dose the line with 25 mg/L?
25. A round storage tank that is going to be put back into service requires disinfection at a dosage of 30 mg/L. If the tank has a diameter of 102 ft and is 28.1 ft tall at the overflow, how many gallons of 10.25% sodium hypochlorite solution will be? Assume the hypochlorite solution weighs the same as water, 8.34 lb/gal.
26. How many gallons of 5.25% bleach is used to make 1 gallon of 3% solution?
27. You need to disinfect a water storage tank that has just been repaired. You have decided to use AWWA Chlorination Method 3 to disinfect the tank. This method requires you to make up a 50 mg/L available chlorine solution that will fill approximately 5% of the tank volume. The tank holds 3 MG. How many lbs of HTH 65% available chlorine will have to be added to meet the above-mentioned requirements?
28. You have just laid 200 feet of 8-inch line, and it needs disinfecting. How many lbs of 65% HTH chlorine will be required to dose the line with 25 mg/L?
29. How many gallons of bleach (5.25% available chlorine) will it take to make a 2% solution when added to enough water to make 8 gallons of hypochlorite?

30. A water treatment plant is feeding an average of 210 lb/day of chlorine. If the dosage is 3.25 mg/L, what is the number of millions of gallons per day being treated?
31. What should the setting be on a chlorinator in pounds per day if the dosage desired is 2.70 mg/L and the pumping rate from the well is 845 gpm?
32. A well is pumping at a rate of 428 gpm. What should be the setting on a chlorinator in pounds per day, if the residual desired is 1.20 mg/L and the chlorine demand is 3.85 mg/L?
33. What should be the setting on a chlorinator in pounds per day, if the residual desired is 1.75 mg/L, the chlorine demand averages 2.45 mg/L, and the pumping rate from the well is 208 gpm?
34. A 24-inch pipeline, 427 feet long, was disinfected with calcium hypochlorite tablets with 65% available chlorine. Determine the chlorine dosage in mg/L, if 7.0 lb of calcium hypochlorite was used. Assume that the hypochlorite is so diluted that it weighs 8.34 lb/gal.
35. A 1.75 MG storage tank needs to be disinfected with a sodium hypochlorite solution that contains 12% available chlorine and weighs 8.97 lb/gal. If the chlorine dosage is to be 50 mg/L, how many gallons of sodium hypochlorite are required?

**Answers**

- |      |               |      |               |
|------|---------------|------|---------------|
| 1.)  | 1.90 MG       | 19.) | 7.69 lb       |
| 2.)  | 90,000 gal    | 20.) | 913.48 gal    |
| 3.)  | 15,391.46 gal | 21.) | 5.3 lb        |
| 4.)  | 192.46 lb     | 22.) | 110.02 lb/day |
| 5.)  | 287.73 lb/day | 23.) | 3.85 lb       |
| 6.)  | 166.13 lb/day | 24.) | 188.32 lb     |
| 7.)  | 11.87 lb      | 25.) | 50.2 gal      |
| 8.)  | 3.03 mg/L     | 26.) | 0.57 gal      |
| 9.)  | 3.3 mg/L      | 27.) | 96.23 lb      |
| 10.) | 50.1 mg/L     | 28.) | 0.17 lb       |
| 11.) | 13.3 gal      | 29.) | 3.05 gal      |
| 12.) | 3.85 lb       | 30.) | 7,750,000 gpd |
| 13.) | 3.21 lb       | 31.) | 27.4 lb/day   |
| 14.) | 2.27 mg/L     | 32.) | 25.95 lb/day  |
| 15.) | 11.55 lb      | 33.) | 10.49 lb/day  |
| 16.) | 1.28 lb       | 34.) | 54.56 mg/L    |
| 17.) | 2.1 mg/L      | 35.) | 677.95 gal    |
| 18.) | 2.2 mg/L      |      |               |



## **Section 6**

### **Pumps, Pressure, and Power**

# Pumps, Power and Force



## Horsepower and Efficiency

...

• TDEC - Fleming Training Center



## Understanding Work & Horsepower

- Work: The exertion of force over a specific distance.
  - Example: Lifting a one-pound object one foot.
- Amount of work done would be measured in foot-pounds
  - (feet) (pounds) = foot-pounds
- (1 pound object) ( moved 20 ft) = 20 ft-lbs of work

• TDEC - Fleming Training Center

• 3

## Understanding Power

- Power is the measure of how much work is done in a given amount of time
- The basic units for power measurement is foot-pounds per minute and expressed as (ft-lb/min)
  - in electric terminology  $\Rightarrow$  Watts
- This is work performed per time (work/time)
- One Horsepower
  - 1 HP = 33,000 ft-lb/min
- In electric terms
  - 1 HP = 746 Watts

• TDEC - Fleming Training Center

• 4

## Types of Horsepower

- **Motor Horsepower** is related to the watts of electric power supplied to a motor
- **Brake Horsepower** is the power supplied to a pump by a motor
- **Water Horsepower** is the portion of power delivered to a pump that is actually used to lift the water
  - Water horsepower is affected by elevation and location of the pump.

• TDEC - Fleming Training Center

• 5

## Motor and Pump Efficiency

- Neither the motor nor the pump will ever be 100% efficient
- Not all the power supplied by the motor to the pump (Brake Horsepower) will be used to lift the water (Water Horsepower)
- Power for the motor and pump is used to overcome friction
- Power is also lost when energy is converted to heat, sound, etc.

• TDEC - Fleming Training Center

• 6

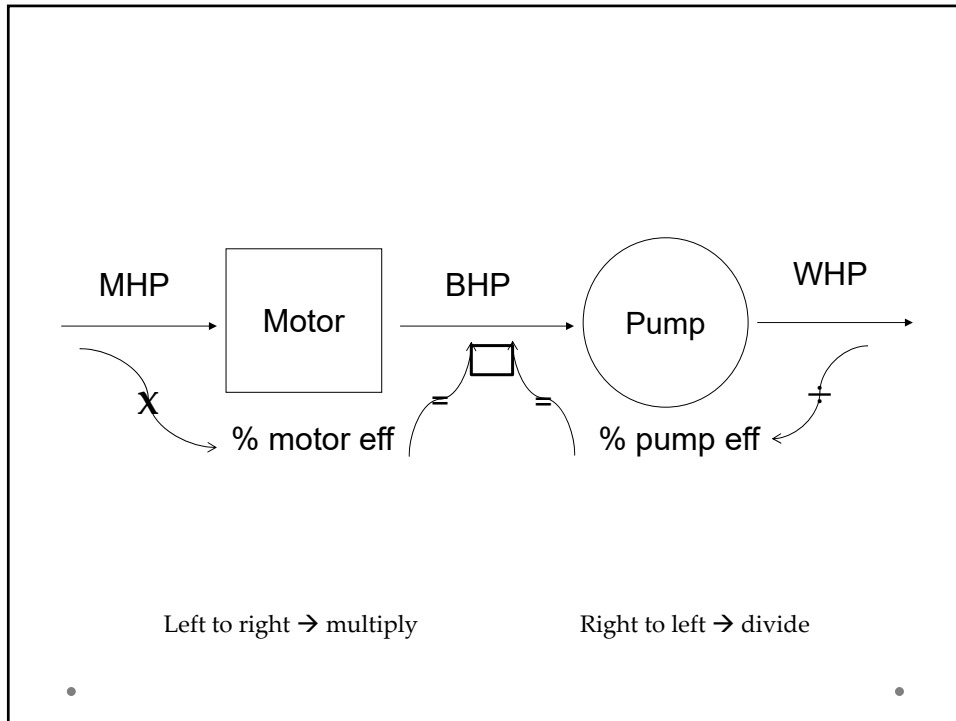

## Computing Water Horsepower

- Water horsepower is the amount of horsepower required to lift the water

$$WHP = \frac{(\text{flow, gpm})(\text{total head, ft})}{3960}$$

$$\frac{33,000 \text{ ft} - \text{lb}/\text{min}}{8.34 \text{ lb}/\text{gal}}$$

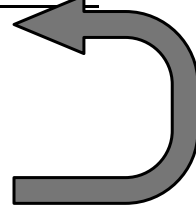

## Example 1

- A pump must pump 3,000 gpm against a total head of 25 feet. What water horsepower will be required?

$$\text{WHP} = \frac{(\text{flow})(\text{head})}{3960}$$

$$\text{WHP} = \frac{(3000 \text{ gpm})(25 \text{ ft})}{3960}$$

$$\text{WHP} = 18.94 \text{ hp}$$

•

•9

## Brake Horsepower

$$\text{bhp} = \frac{(\text{flow, gpm})(\text{head, ft})}{(3960)(\% \text{ pump eff.})}$$

OR

$$\text{bhp} = \frac{\text{water hp}}{\% \text{ pump eff.}}$$

•

•10

## Example 2

- Determine the horsepower produced by a motor at a flow of 1500 gpm against a total head of 25 ft if the pump is 82% efficient.

$$\text{bhp} = \frac{(\text{flow, gpm})(\text{head, ft})}{(3960)(\% \text{ pump eff.})}$$

$$\text{bhp} = \frac{(1500 \text{ gpm})(25 \text{ ft})}{(3960)(0.82)}$$

$$\text{bhp} = \frac{37500}{3247.2}$$

$$\text{bhp} = 11.5 \text{ hp}$$

## Motor Horsepower

$$\text{mhp} = \frac{(\text{flow, gpm})(\text{head, ft})}{(3960)(\% \text{ pump eff})(\% \text{ motor eff})}$$

$$\text{mhp} = \frac{\text{water hp}}{(\% \text{ pump eff})(\% \text{ motor})}$$

$$\text{mhp} = \frac{\text{bhp}}{\% \text{ motor eff}}$$

## Example 3

- A certain pumping job will require 9 hp. If the pump is 80% efficient and the motor is 72% efficient, what motor horsepower will be required?

$$\text{mhp} = \frac{\text{water hp}}{(\% \text{ pump eff})(\% \text{ motor})}$$

$$\text{mhp} = \frac{9 \text{ hp}}{(0.80)(0.72)}$$

$$\text{mhp} = \frac{9 \text{ hp}}{0.576}$$

$$\text{mhp} = 15.6 \text{ hp}$$

## Typical Efficiency

- Pumps are generally 50-85 % efficient
- Motors are usually 80-95% efficient
- Combined efficiency of the motor and pump is called wire-to-water efficiency

## Wire-to-Water Efficiency

$$w - w = \frac{\text{water hp}}{\text{motor hp}} \times 100$$

OR

$$w - w = \frac{(\text{flow, gpm})(\text{head, ft})(0.746 \text{ kW}/\text{hp})}{(3960)(\text{electric demand, kW})} \times 100$$

## Example 4

- A pump must move 2500 gpm against a total dynamic head of 115 feet. If the motor requires 75 kW of power, what is the wire-to-water efficiency?

$$w - w = \frac{(\text{flow, gpm})(\text{head, ft})(0.746 \text{ kW}/\text{hp})}{(3960)(\text{electric demand, kW})} \times 100$$

$$w - w = \frac{(2500\text{gpm})(115\text{ft})(0.746 \text{ kW}/\text{hp})}{(3960)(75\text{kW})} \times 100$$

$$w - w = \frac{214475}{297000} \times 100$$

$$w - w = 72.2\%$$

# Electrical

...

## A Few Electrical Terms...

- Power (Watts) - amount of work done
- Voltage (volts) - electrical “pressure” available to cause flow of electricity
- Amperage (amps) - the amount of flow of electricity
- Power = (voltage)(amperage)  
or
- Watts = (volts)(amps)

• 18



# Amperage

- Current is equal to the voltage applied to the circuit divided by the resistance of the circuit
- Ohm's Law:

$$\text{amps} = \frac{\text{volts}}{\text{ohms}}$$

## Example 5

- A circuit contains a resistance of 6 ohms and a source voltage of 3 volts. How much current (amps) flows in the circuit?

$$\text{amps} = \frac{\text{volts}}{\text{ohms}}$$

$$\text{amps} = \frac{3 \text{ volts}}{6 \text{ ohms}}$$

$$\text{amps} = 0.5 \text{ amps}$$

## Electromotive Force

- Electromotive force is the characteristic of any energy source capable of driving electric charge around a circuit
  - Aka voltage

$$\text{emf, volts} = (\text{current, amps})(\text{resistance, ohms})$$

## Example 6

- A circuit has a resistance of 12 ohms with a current of 0.25 amps. What is the electromotive force in volts?

$$\text{emf, volts} = (\text{current, amps})(\text{resistance, ohms})$$

$$\text{emf} = (0.25 \text{ amps})(12 \text{ ohms})$$

$$\text{emf} = 3 \text{ volts}$$

## Watts

- Unit of power
- 1 hp = 0.746 kW
- 1 kW = 1000 W
- Alternating current (AC circuit)

$$\text{Watts} = (\text{volts})(\text{amps})(\text{power factor})$$

$$W = V * A * \text{pf}$$

- Direct current (DC circuit)

$$\text{Watts} = (\text{volts})(\text{amps})$$

$$W = V * A$$

## Example 7

- An alternating current motor has a voltage of 5 volts and a current of 3 amps. If the nameplate show that the motor has a power factor of 0.97, what is the power of the motor in watts?

$$\text{Watts} = (\text{volts})(\text{amps})(\text{power factor})$$

$$W = (5 \text{ volts})(3 \text{ amps})(0.97)$$

$$W = 14.55 \text{ watts}$$

# Force

...

# Force

- Force is a push or pull on an object resulting from the object's interaction with another object
- Measured in pounds (lbs)
- 1 psi = 2.31 ft of head
- 1 ft of head = 0.433 psi

$$\text{Force, lbs} = (\text{pressure, psi})(\text{area, in}^2)$$

$$F = P * A$$

## Force and Pressure

- Force is a push or pull measured in weight (pounds)
  - Force on the bottom of a tank is a measure of the weight of the water above it
  - The deeper the water, the more force on the bottom of the tank
- Pressure is a measure of the force, or weight, pushing against a specified area (in<sup>2</sup> or ft<sup>2</sup>)

$$\text{Pressure, psi} = \frac{\text{lb}}{\text{in}^2}$$

- One foot of water will have a pressure of 0.433 psi
  - 1 ft of water = 0.433 psi
  - 1 psi = 2.31 ft of water

## Force

- Pressure exerted on a surface corresponds to the force applied to the surface.
- Force = (pressure, psi) (area, ft<sup>2</sup>)

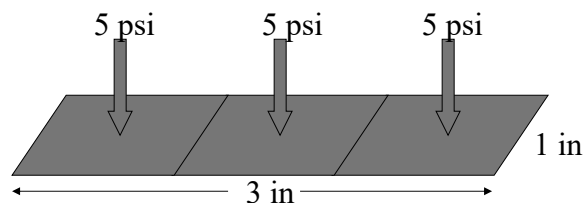

$$\text{Force} = (5 \text{ psi})(3 \text{ in})(1 \text{ in}) = 15 \text{ lb}$$

## Example 8

- Determine the force, in lbs, being exerted on a surface that is 3 inches by 4 inches with 15 psi of pressure.

$$\text{Force, lbs} = (\text{pressure, psi})(\text{area, in}^2)$$

$$\text{Force, lbs} = (15 \text{ psi})(3 \text{ in})(4 \text{ in})$$

$$\text{Force, lbs} = 180 \text{ lbs}$$



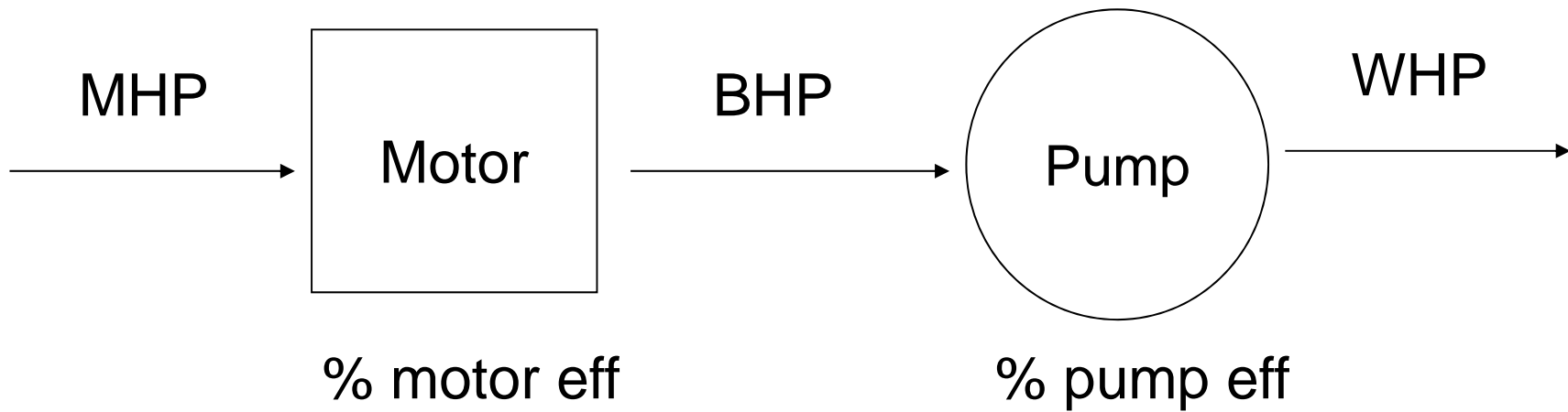

Left to right → multiply

Right to left → divide



## Pumps, Power and Force

1. Determine the water horsepower for a pumping job that must pump 531 gpm against 25 feet of head.
2. What is the horsepower produced by a motor if the water horsepower is 34 hp? The pump in use is 80% efficient.
3. Calculate the motor horsepower for a job that is pumping 1325 gpm against a total dynamic head of 55 ft. The pump is 85% efficient while the motor is 90% efficient.
4. The pump supplies 59 hp to perform a job. If the motor is 91% efficient and the pump is 47% efficient, how much mhp will be supplied to the motor?

5. A pump must transport 1550 gpm against 175 ft of head. If the motor requires 115 kilowatts of power, what is the wire-to-water efficiency of the job?
  
  
  
  
  
  
  
  
  
  
6. Determine the force, in lbs, exerted on a surface that is 45 in<sup>2</sup> with a pressure of 29 psi.
  
  
  
  
  
  
  
  
  
  
7. If the pressure at the bottom of the tank is 7.9 psi, what is the height of the water in the tank in feet?
  
  
  
  
  
  
  
  
  
  
8. If a pump discharges 8,000 gallons in 90 minutes, how many gallons per minute is the pump discharging?

## Applied Math for Distribution Systems

### Pumps, Pressure, and Power

#### Flow

1. Determine the number of gallons a pump discharges in 1 hour if it is pumped at a rate of 1340 gpm.
2. If a pump discharges 7,880 gal in 2 hours and 13 minutes, how many gallons per minute is the pump discharging?

#### Water Horsepower

3. A flow of 555 gpm must be pumped against a head of 40 feet. What is the horsepower required?
4. A pump must pump 1600 gpm against a total head of 50 ft. What horsepower is required for this work?
5. Suppose a pump is pumping against a total head of 46 feet. If 850 gpm is to be pumped, what is the horsepower requirement?
6. A pump delivering a flow of 835 gpm against a total head of 35.6 feet. What is the water horsepower?

**Brake Horsepower**

7. If a pump is to deliver 360 gpm of water against a total head of 95 feet, and the pump has an efficiency of 85 percent, what horsepower must be supplied to the pump?
  
8. If a pump is to deliver 450 gpm of water against a total head of 90 feet, and the pump has an efficiency of 70 percent, what horsepower must be supplied to the pump?
  
9. A total of 35 hp is required for a particular pumping application. If the pump efficiency is 85%, what is the brake horsepower required?

**Motor Horsepower**

10. A certain pumping job requires a flow of 450 gpm against a head of 89 feet. If the pump is 84% efficient and the motor is 73% efficient, what motor horsepower will be required?
  
11. What is the motor horsepower for a pump with the following parameters?  
Motor eff: 91%                      Total head: 98 ft  
Pump eff: 81%                      Flow: 2.44 MGD
  
12. You have calculated that a certain pumping job will require 9 whp. If the pump is 80 percent efficient and the motor is 72 percent efficient, what motor horsepower will be required?

13. The motor nameplate indicated that the output of a certain motor is 20 hp. How much horsepower must be supplied to the motor if the motor is 90 percent efficient?
14. The motor nameplate indicated that the output of a certain motor is 35 hp. How much horsepower must be supplied to the motor, if the motor is 90% efficient?

### **Pressure and Head**

15. Convert a pressure of 26 ft to pounds per square inch.
16. If the water level in a tank is 31.78 ft, what is the pressure in psi at the bottom?
17. The pressure gauge on the discharge line from an influent pump reads 72.3 lbs per square inch (psi). What is the equivalent head in feet?
18. What is the depth (in ft) of water in a tank if the psi is 56.7?
19. The motor horsepower requirement has been calculated to be 45 hp. How many kilowatts electric power does this represent? Remember, 1 hp = 746 watts)

20. What would be the horsepower on a motor that is rated at 12 amps and 440 volts?

21. What would be the horsepower on a motor that is rated at 16 amps and 440 volts?

### **Practice Problems**

22. Based on the gallons per minute to be pumped and the total head the pump must pump against, the water horsepower requirement was calculated to be 18.5 whp. If the motor supplies the pump with 21 hp, what must be the efficiency of the pump?

23. If 20 hp is supplied to a motor (mhp), what is the whp if the motor is 85% efficient and the pump is 80% efficient?

24. A supply tank is located at an elevation of 118 ft. The discharge point is at an elevation of 215 ft. What is the static head (in feet)?

25. A pump must pump against a total dynamic head of 70 ft at a flow rate of 700 gpm. The liquid to be pumped has a specific gravity of 1.3. What is the water horsepower required for this pumping application?

26. If the pressure at the bottom of the tank is 14.7 psi, what is the height of the water in the tank?
27. What would be the horsepower on a motor that is rated at 36 amps and 440 volts?
28. A pressure of 42 psig is equivalent to how many feet of water?
29. A hypochlorite solution is being pumped from a small tank that is 2.5 ft in diameter. If the level in the tank drops 2.05 ft in 3.5 hrs, how many gallons per minute of hypochlorite solution was used?
30. What is the motor hp if the bhp is 68 and the motor efficiency is 87%?
31. If a pump is to deliver 360 gpm of water against a total head of 95 feet, and the pump has an efficiency of 85 percent, what horsepower must be supplied to the pump?
32. The motor horsepower of a pump is 22 hp. If the water horsepower is 17 hp, what is the wire to water efficiency?

33. A pump must pump 1500 gpm against a total head of 40 ft. What horsepower is required for this work?
34. If 25 horsepower is supplied to a motor (mhp), water horsepower (whp) if the motor is 80% efficient and the pump is 75% efficient?
35. The elevations of two water surfaces are 780 ft and 624 ft what is the total dynamic head in feet between the two water surfaces?
36. What is the water horsepower of a pump that is producing 1,523 gpm against a head of 65 feet?
37. Suppose that 10 kilowatts (kW) power is supplied to a motor. If the water horsepower is 12 hp, what is the wire-to-water efficiency of the motor?
38. If a pump is to deliver 630 gpm of water against a total head of 102 feet, and the pump has an efficiency of 78%, what power must be supplied to the pump?
39. The motor horsepower is 25 hp. If the motor is 89% efficient, what is the brake horsepower?



40. The brake horsepower is 34.4 hp. If the motor is 86% efficient, what is the motor horsepower?
41. Convert 32 psig to ft of head.
42. A water tank has 250 feet of water in it. What is the pressure gage reading at ground level?
43. A water tank has a pressure gage located 2 ft below the ground level in a pit. Its current reading is 60 psig. How many feet of water are in the tank?
44. The elevations of two water surfaces are 320 ft and 241 feet. What is the total static head in feet?
45. What is the pressure head at a fire hydrant in feet if the pressure gauge reads 189 psi?
46. The pressure at the bottom of a reservoir is 132 psi. What is the depth at that point?

47. If the water level in a reservoir is 625 ft, what is the pressure in pounds per square in at an inlet if it is 165 ft from bottom?
48. A total of 50 hp is supplied to a motor. If the wire-to-water efficiency of the pump and motor is 62%, what will the whp be?
49. A pump is delivering a flow of 1,035 gpm against 46.7 feet of head. What horsepower will be required?
50. A pump must pump 3,000 gpm against a total head of 25 feet. What horsepower (water horsepower) will be required to do the work?
51. You have calculated that a certain pumping job will require 6 whp. If the pump is 80 percent efficient and the motor is 90 percent efficient, what motor horsepower will be required?
52. If a pump discharges 840 gpm, how many gallons will it discharge in 4 hours and 20 minutes?
53. If the pressure head at a fire hydrant is 210 ft, what is the psi?

54. What is the brake horsepower if 62 hp is supplied to a motor with 87% efficiency?
55. A head of 310 ft of water is equivalent to what pressure in psi?
56. A water tank has a pressure gage located 4 ft above the ground. Its current reading is 60 psig. How many feet of water are in the tank?
57. Suppose a pump is pumping a total head of 76.2 feet. If 900 gpm is to be pumped, what is the water horsepower requirement?
58. A pump must pump 2,500 gpm against a total head of 73 feet. What horsepower (water horsepower) will be required to do the work?
59. Suppose that 31 kilowatts (kW) power is supplied to a motor. If the brake horsepower is 33 bhp, what is the efficiency of the motor?
60. What would be the horsepower on a motor that is rated at 12 amps and 440 volts if it has a power factor of 0.9?

61. If the motor horsepower is 50 hp and the brake horsepower is 43 hp, what is the percent efficiency of the motor?
62. What is the psi at the bottom of a tank if the water level is 28.14 ft deep?
63. A total of 40 hp is required for a particular pumping application. If the pump efficiency is 80%, what is the brake horsepower required?
64. If the pressure head on a fire hydrant is 350 ft, what is the pressure in psi?
65. Determine the brake horsepower if the motor has an efficiency of 88 % and the horsepower is 45.
66. If the pressure head at a blow off valve is 136 psi, what is the pressure in feet?

**ANSWERS**

- |               |              |                |                 |
|---------------|--------------|----------------|-----------------|
| 1. 80,400 gal | 18. 131 ft   | 35. 156 ft     | 52. 218,400 gal |
| 2. 59.25 gpm  | 19. 33.6 kW  | 36. 25.0 ft    | 53. 90.91 psi   |
| 3. 5.6 hp     | 20. 7.1 hp   | 37. 89.5%      | 54. 53.9 hp     |
| 4. 20.2 hp    | 21. 9.4 hp   | 38. 20.8 hp    | 55. 134.2 psi   |
| 5. 9.9 hp     | 22. 88.1%    | 39. 22.3 hp    | 56. 142.6 ft    |
| 6. 7.5 hp     | 23. 13.6 hp  | 40. 40 hp      | 57. 17.3 hp     |
| 7. 10.2 hp    | 24. 97 ft    | 41. 73.92 ft   | 58. 46.1 hp     |
| 8. 14.6 hp    | 25. 16.1 hp  | 42. 108.23 psi | 59. 79.4%       |
| 9. 41.2 hp    | 26. 33.96 ft | 43. 136.6 ft   | 60. 6.4 hp      |
| 10. 16.5 hp   | 27. 21.2 hp  | 44. 79 ft      | 61. 86%         |
| 11. 57 mhp    | 28. 97.02 ft | 45. 436.59 ft  | 62. 12.18 psi   |
| 12. 15.6 hp   | 29. 0.36 gpm | 46. 304.92 ft  | 63. 50 hp       |
| 13. 22.2 hp   | 30. 78.2 hp  | 47. 199.13 psi | 64. 151.52 psi  |
| 14. 38.9 hp   | 31. 10.2 hp  | 48. 31 hp      | 65. 39.6 hp     |
| 15. 11.26 psi | 32. 77.3%    | 49. 12.2 hp    | 66. 314.16 ft   |
| 16. 13.8 psi  | 33. 15.2 hp  | 50. 18.9 hp    |                 |
| 17. 167 ft    | 34. 15 hp    | 51. 8.3 hp     |                 |



**Section 7**  
**Miscellaneous**

## Miscellaneous



## Water Use

- The average amount of water each person in a particular area uses on a daily basis

$$\text{gallons/capita/day} = \frac{\text{volume of water produced, gpd}}{\text{population}}$$



## Example 1

- A water utility is expanding their treatment plant. They want to be able to supply 21 MGD to 125,000 persons. What would be the gallons/capita/day?

$$\text{gal/capita/day} = \frac{\text{volume of water produced, gpd}}{\text{population}}$$

$$\text{gal/capita/day} = \frac{21,000,000 \text{ gpd}}{125,000 \text{ capita}}$$

$$\text{gal/capita/day} = 168 \text{ gpd/capita}$$

## Leakage

- To determine the amount of water lost due to a leak

$$\text{leakage, gpd} = \frac{\text{volume, gal}}{\text{time, days}}$$

## Example 2

- A water leak is found in a pipe gallery. It is estimated that approximately 3,000 gallons was lost over a day and a half. What is the leakage in gallons per day?

$$\text{leakage, gpd} = \frac{\text{volume, gal}}{\text{time, days}}$$

$$\text{leakage, gpd} = \frac{3,000 \text{ gal}}{1.5 \text{ days}}$$

$$\text{leakage, gpd} = 2,000 \text{ gpd}$$

## SLOPE AND C-FACTOR



Department of  
**Environment &  
Conservation**

## Slope

- The **slope** is a measure of the steepness of a line, or a section of a line, connecting two points

$$\text{slope, \%} = \frac{\text{drop or rise}}{\text{distance}} \times 100$$

FTC  
Formula Book

$$\text{slope, \%} = \frac{\text{energy loss, ft}}{\text{distance, ft}} \times 100$$

$$\text{slope, \%} = \frac{\text{head loss, ft}}{\text{distance, ft}} \times 100$$

## Example 3

- Hydrant 1 is located at 547 ft. Hydrant 2 is located at 492 ft. The hydrants are 750 ft away from each other. What is the slope?

$$\text{slope, \%} = \frac{\text{drop or rise}}{\text{distance}} \times 100$$

$$\text{height} = 547 \text{ ft} - 492 \text{ ft} = 55 \text{ ft}$$

$$\text{slope, \%} = \frac{55 \text{ ft}}{750 \text{ ft}} \times 100$$

$$\text{slope, \%} = 0.073 \times 100$$

$$\text{slope, \%} = 7.3\%$$

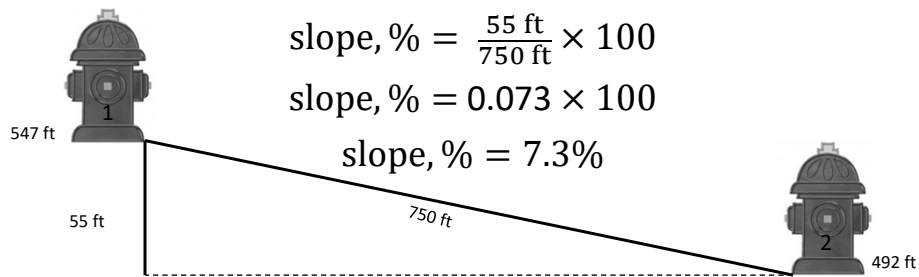

## Example 4

- The pressure readings at hydrant 1 is 40 psi and at hydrant 2 is 32 psi. The hydrants are 600 ft apart. What is the slope?

Determine drop or rise  
 $40 \text{ psi} - 32 \text{ psi} = 8 \text{ psi}$   
 Convert to ft  
 $8 \text{ psi} \times \frac{2.31 \text{ ft}}{\text{psi}} = 18.48 \text{ ft}$

$$\text{slope, \%} = \frac{\text{drop or rise}}{\text{distance}} \times 100\%$$

$$\text{slope, \%} = \frac{18.48 \text{ ft}}{600 \text{ ft}} \times 100\%$$

$$\text{slope, \%} = 0.0308 \times 100\%$$

$$\text{slope, \%} = 3.08\%$$



## Example 5

- A pressure gauge at an elevation 84 ft set at a fire hydrant read 76 psi. Another pressure gauge at elevation 103 ft read 53 psi. The hydrants are 800 ft apart. What is the slope?

$$\text{slope, \%} = \frac{\text{drop or rise}}{\text{distance}} \times 100\%$$

FTC  
Formula Book

$$\text{slope, \%} = \frac{\text{energy loss, ft}}{\text{distance, ft}} \times 100$$

$$\text{slope, \%} = \frac{\text{head loss, ft}}{\text{distance, ft}} \times 100$$

Gauge 1 = 76 psi at 84 ft  
Gauge 2 = 53 psi at 103 ft

## Example 5 Cont'd

1. Find difference of pressure in feet.  
 $(76 \text{ psi} - 53 \text{ psi})(2.31 \text{ ft/psi}) = 53.13 \text{ ft}$
2. Find difference of elevation in feet.  
 $103 \text{ ft} - 84 \text{ ft} = 19 \text{ ft}$
3. Drop or rise = diff of pressure + diff of elevation  
 $\text{drop or rise} = 53.13 \text{ ft} + 19 \text{ ft} = 72.13 \text{ ft}$

Drop or rise = 72.13 ft

## Example 5 Cont'd

4. Find slope.

$$\text{slope, \%} = \frac{\text{drop or rise}}{\text{distance}} \times 100$$

$$\text{slope, \%} = \frac{72.13 \text{ ft}}{800 \text{ ft}} \times 100$$

$$\text{slope, \%} = 0.09 \times 100$$

$$\text{slope, \%} = 9\%$$

## C-Factor

- A value used to indicate the roughness of the interior of a pipe
- Also known as the Hazen-Williams roughness coefficient
- The higher the C factor, the smoother the pipe, the greater the carrying capacity, and the smaller the friction or energy losses from water flowing in the pipe

TDEC - Fleming Training Center

13

## C-Factor

C – factor

flow, gpm

$$= \frac{\text{flow, gpm}}{(193.75)(\text{diameter, ft})^{2.63}(\text{slope, as a decimal})^{0.54}}$$



key or   $y^x$   
 This key will take a number to another power.  
 $9 \square 3 = 9 \times 9 \times 9 = 729$   
 Nine cubed or nine to the third power is 729.  
 $2 \square 5 = 2 \times 2 \times 2 \times 2 \times 2 = 32$   
 Two to the fifth power is 32.

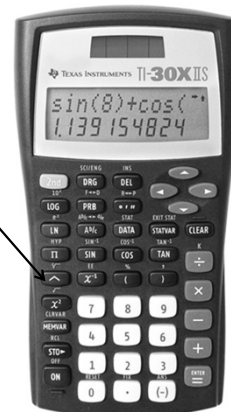

TDEC - Fleming Training Center

## Example 8

- A 24-inch diameter water main is carrying a flow of 3,000 gpm. Pressure gauges installed 1,000 ft apart on the main indicate that the elevation of the pressure head at the upstream pressure gauge is 101 feet and 100 feet at the downstream gauge. Calculate the C factor for this pipe.

## Example 8 Cont'd

- **Known**
  - Flow, gpm = 3,000 gpm
  - Diameter = 24 in = 2 ft
  - Distance = 1,000 ft
  - Pressure 1 = 101 ft
  - Pressure 2 = 100 ft
- **Step 1. Find Slope**

$$\text{Slope} = \frac{\text{rise or drop, ft}}{\text{distance, ft}} \times 100$$

$$\text{Slope} = \frac{101 \text{ ft} - 100 \text{ ft}}{1000 \text{ ft}} \times 100$$

$$\text{Slope} = 0.1 \%$$

## Example 8 Cont'd

Flow, gpm = 3,000 gpm  
Diameter = 24 in = 2 ft  
Distance = 1,000 ft  
Slope = 0.1%

$$C \text{ factor} = \frac{\text{flow, gpm}}{(193.75)(\text{diameter})^{2.63}(\text{slope})^{0.54}}$$

$$C \text{ factor} = \frac{3000 \text{ gpm}}{(193.75)(2 \text{ ft})^{2.63}(0.001)^{0.54}}$$

$$C \text{ factor} = \frac{3000}{(193.75)(6.1903)(0.024)}$$

$$C \text{ factor} = \frac{3000}{28.7849}$$

$$C \text{ factor} = 104.22$$



## Miscellaneous Example Problems

1. A water system wants to expand their treatment plant. The new facility will be able to support 500,000 persons with 96.5 MGD. What is the amount of water used in gallons per capita per day?
2. A 36-inch water main has a leak of 32,000 gallons. It takes 4 days to find and repair the leak. How many gallons per day did the line leak?
3. Two hydrants are located 750 feet apart. The elevation of the first hydrant is 157 ft and the second hydrant is 103 ft. What is the % slope of the line between the two gauges?

4. Two hydrants are 1250 feet apart. To determine the slope between the lines, pitot gauges are installed on each hydrant. The pressure reading at the first hydrant is 75 psi while the pressure reading at the second hydrant is 64 psi. What is the calculated slope (%) between the two hydrants?

## Applied Math for Distribution Systems

### Miscellaneous

1. On Tuesday, a meter read 001234 gallons. The following Tuesday, it read 450345 gallons. What is the daily average consumption in gallons per day?
2. What is the leakage rate in gpd for a 48-inch main that ruptures? It is determined that in 6 hours the break emptied a storage tank that is 30 feet in diameter and contained water 17 feet deep.
3. A water plant serves 59,400 people. If it treats a yearly average of 7.82 MGD, what are the gallons per capita per day?
4. Determine the percent slope for a pipe if the upstream pressure gauge reads 154 psig and the downstream pressure reads 149 psi. The two gauges are 3,820 ft apart.
5. Two hydrants are 750 ft apart. Hydrant 1 is located at an elevation of 129 feet. Hydrant 2 is located at an elevation of 157 feet. What is the percent slope?
6. Determine the approximate C factor given the following data:  
Diameter of pipe = 18 in                      Upstream pressure gauge = 87 ft  
Flow = 2,250 gpm                              Downstream pressure gauge = 84 ft  
Distance between gauges = 1,500 ft

7. A 45 ft diameter storage tank loses 15 psi of pressure due to a leak over a 24-hour period. What is the leakage rate in gpd?
  
  
  
  
  
  
  
  
  
  
8. Pressure readings on a main are measured at 2 hydrants separated by 750 feet. The pressure reading at hydrant #1 is 92 psi and the pressure reading at hydrant #2 is 75 psi. What is the slope of the main?
  
  
  
  
  
  
  
  
  
  
9. A 0.5-million-gallon storage tank leaks 200 gallons over a 24-hour period. What is leakage rate in gpd?
  
  
  
  
  
  
  
  
  
  
10. A water plant serves 41,312 people. If it treats a yearly average of 6.54 MGD, what are the gallons per capita per day?
  
  
  
  
  
  
  
  
  
  
11. Estimate the C factor for the following system:  
Water main diameter = 8 in  
Flow = 650 gpm  
Pressure difference = 6 ft for gauges 400 ft apart

12. The pressure reading of a pitot gauge at an elevation of 231 feet is 45 psi. The pressure reading of another pitot gauge 2500 feet away is 69 psi at an elevation of 200 ft. What is the slope?
13. The friction loss in a 16-inch pipe flowing at 850 gpm is 0.08 feet of head per 100 feet. At the storage tank, the pressure is 91 psi with the water flowing at 850 gpm. What will the pressure (psi) be two miles from the tank?
14. If a water treatment plant treats 15 MGD, and serves 150,900 persons, what are the gallons per capita per day?
15. Determine the approximate C factor for a pipe that is 2 ft in diameter and has a flow of 3,425 gpm given the following data:  
Upstream pressure gauge = 154 ft  
Downstream pressure gauge = 149 ft  
Distance between gauges = 3,820 ft

16. The friction loss in a 10-inch pipe flowing at 1,400 gpm is 18.7 feet of head per 1,000 feet. At the storage tank, the pressure is 85 psi with the water flowing at 1,400 gpm. What will the pressure be 1/2 mile from the tank?

Answers

1. 64,158.71 gpd
2. 359,354.16 gpd
3. 132 gpcd
4. 0.30%
5. 3.73%
6. 115
7. 412,002.19 gpd
8. 5.24%
9. 200 gpd
10. 158 gpcd
11. 94
12. 3.46%
13. 87.34 psi
14. 99.4 gal/capita/day
15. 103
16. 63.6 psi

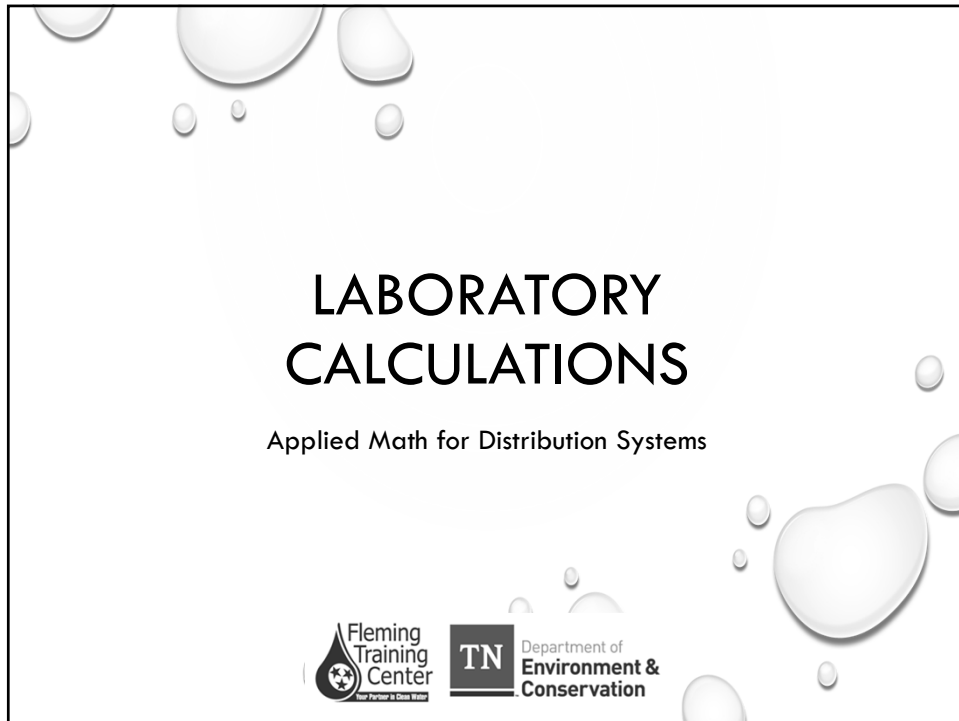

## **Section 8**

### **Laboratory Calculations**

A decorative graphic of various-sized water droplets is scattered across the page, primarily concentrated in the top-left and bottom-right corners.

# LABORATORY CALCULATIONS

Applied Math for Distribution Systems



Fleming Training Center  
Your Partner in Clean Water

TN Department of Environment & Conservation

A decorative graphic of various-sized water droplets is scattered across the page, primarily concentrated in the top-left and bottom-right corners.

Fleming Training Center  
Your Partner in Clean Water

TN Department of Environment & Conservation

# TEMPERATURE CONVERSIONS



## TEMPERATURE SCALES

The **Fahrenheit** scale is named for the 18th-century German physicist Daniel Fahrenheit. His scale is based on 32 for the freezing point of water and 212 for the boiling point of water, the interval between the two being divided into 180 parts. The scale was in common use in English speaking countries until the 1970's when Europe and Canada adopted the centigrade (Celsius) scale. The U.S is the only country that still uses the Fahrenheit scale.

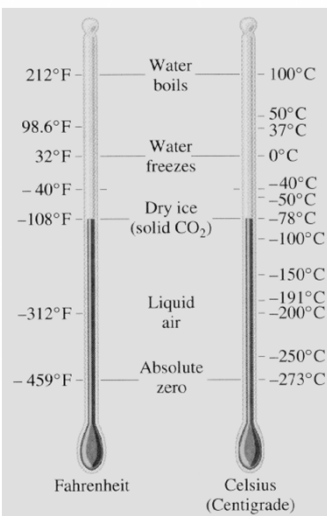

The **Celsius** temperature scale is named for the in the Swedish astronomer Anders Celsius who invented the scale in 1742.

The scale is based on 0 for the freezing point of water and 100 for the boiling point of water.

It is sometimes called the centigrade scale because of the 100-degree interval between the defined points.

3

## TEMPERATURE FORMULAS

- Degrees Fahrenheit

$$^{\circ}\text{F} = (^{\circ}\text{C})(1.8) + 32$$

Remember your  
Order of Operations!!

- Degrees Celsius

$$^{\circ}\text{C} = \frac{(^{\circ}\text{F} - 32)}{1.8}$$

### EXAMPLE 1

- Determine the temperature in °F if the temperature is measured as 43°C.

$$^{\circ}\text{F} = (^{\circ}\text{C})(1.8) + 32$$

$$^{\circ}\text{F} = (43)(1.8) + 32$$

$$^{\circ}\text{F} = 77.4 + 32$$

$$^{\circ}\text{F} = 109.4^{\circ}\text{F}$$

### EXAMPLE 2

- Water temperature is measured with a pH probe to be 87 °F. What is this in Celsius?

$$^{\circ}\text{C} = \frac{(^{\circ}\text{F} - 32)}{1.8}$$

$$^{\circ}\text{C} = \frac{(87 - 32)}{1.8}$$

$$^{\circ}\text{C} = \frac{55}{1.8}$$

$$^{\circ}\text{C} = 30.56^{\circ}\text{C}$$

## SPECIFIC GRAVITY AND DENSITY



## DENSITY

- A measure of the weight per unit volume
  - lb/ft<sup>3</sup>
  - lb/gal
- Density of water varies slightly with temperature and pressure
  - Maximum density of water reached at 4°C
- Density of gases changes significantly with changes in temperature and pressure

## DENSITY OF WATER

- 1 gallon of water weighs 8.34 lbs, therefore the density of the water is **8.34 lb/gal**

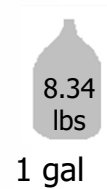

- 1 cubic foot of water weighs 62.4 lbs, therefore the density of the water is **62.4 lb/ft<sup>3</sup>**

- Because there are 7.48 gal/ft<sup>3</sup>

$$\left(\frac{1 \text{ ft}^3}{1 \text{ ft}^3}\right) \left(\frac{7.48 \text{ gal}}{1 \text{ ft}^3}\right) \left(\frac{8.34 \text{ lb}}{1 \text{ gal}}\right) = 62.4 \text{ lb/ft}^3$$

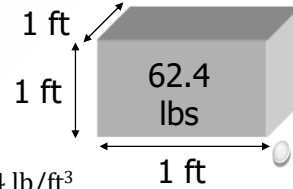

## SPECIFIC GRAVITY

- Compares density of a substance to a standard density
- Does not have units
- For solids and liquids
  - Compare to standard density of water
    - 8.34 lb/gal
    - 62.4 lb/ft<sup>3</sup>
- Specific gravity of water  $\approx 1.0$

## SPECIFIC GRAVITY

$$\text{Specific Gravity} = \frac{\text{specific weight of substance, lb/gal}}{8.34 \text{ lb/gal}}$$

- Specific weight of substance = DENSITY
- Densities (specific weights) can be measured in  $\text{lb/gal}$  or  $\text{lb/ft}^3$ 
  - Be sure the units are consistent within the equation

## EXAMPLE 3

- Determine the specific gravity of a liquid chemical that has a density of 10.5 lb/gal.

$$\text{Specific Gravity} = \frac{\text{specific weight of substance, lb/gal}}{8.34 \text{ lb/gal}}$$

$$\text{S. G.} = \frac{10.5 \text{ lb/gal}}{8.34 \text{ lb/gal}}$$

$$\text{S. G.} = 1.26$$

## COMPOSITE SAMPLES

## COMPOSITE SAMPLES

- Representative of average water quality of a location over a period of time
- Series of grab samples mixed together
- Determines average concentration
- Not suitable for all tests (i.e. pH, chlorine, total coliform)

\*\*Note there are no units in the equation. It is up to YOU to make sure the units within the equation match.

Composite Sample Single Portion

$$= \frac{(\text{Instantaneous Flow})(\text{Total Sample Volume})}{(\text{Number of Portions})(\text{Average Flow})}$$

## EXAMPLE 4

- Filter effluent flows at 2.0 gpm/ft<sup>2</sup> on average. You want to collect 5 samples for a composite sample of 10 gallons. If the water is flowing at 2.7 gpm/ft<sup>2</sup> at the time of sampling, what should the volume in gallons of sample #1 be?

Composite Sample Single Portion

$$= \frac{(\text{Instantaneous Flow})(\text{Total Sample Volume})}{(\text{Number of Portions})(\text{Average Flow})}$$

## EXAMPLE 4 CONT'D

Avg flow = 2.0 gpm/ft<sup>2</sup>  
 # samples = 5  
 Total volume = 10 gal  
 Inst. Flow = 2.7 gpm/ft<sup>2</sup>

Composite Sample Single Portion

$$= \frac{(\text{Instantaneous Flow})(\text{Total Sample Volume})}{(\text{Number of Portions})(\text{Average Flow})}$$

$$= \frac{(2.7 \text{ gpm/ft}^2)(10 \text{ gal})}{(5)(2.0 \text{ gpm/ft}^2)}$$

$$= \frac{27 \text{ gal}}{10}$$

$$= 2.7 \text{ gal}$$

## Laboratory Calculations

1. The average water temperature for a utility is  $18^{\circ}\text{C}$ . What is this temperature in degrees Fahrenheit?
2. Determine the temperature in degrees Celsius for a water sample that was measured to be  $45^{\circ}\text{F}$ .
3. A chemical shipment is delivered. The MSDS shows the density of the substance to be  $57.9 \text{ lb/ft}^3$ . What is the specific gravity of this chemical?
4. Determine the density of a substance in  $\text{lb/gal}$  that has a specific gravity of 1.46.



**Applied Math for Distribution Systems**  
**Laboratory Calculations**  
**Practice Problems**

1. Convert 170°F to °C.
  
  
  
  
  
  
  
  
  
  
2. Mechanical seals should never exceed 160°F. What is this temperature expressed in °C?
  
  
  
  
  
  
  
  
  
  
3. What is the specific gravity of a polymer solution that weighs 11.1 lb/gal?
  
  
  
  
  
  
  
  
  
  
4. Determine the specific gravity of a polymer solution that weighs 1067 lb/gal.
  
  
  
  
  
  
  
  
  
  
5. A gallon of solution is weighed. After the weight of the container is subtracted, it is determined that the weight of the solution is 9.1 lb. What is the density of the solution in lb/ft<sup>3</sup>?
  
  
  
  
  
  
  
  
  
  
6. Find the density (lbs/ft<sup>3</sup>) of a certain oil that has a S.G. of 0.92.
  
  
  
  
  
  
  
  
  
  
7. Find the density (lbs/gal) of caustic soda that has a S.G. of 1.530.

8. The density of an unknown liquid is  $74.1 \text{ lb/ft}^3$ . What is the specific gravity of the liquid?
  
9. The effluent of a treatment plant is  $23^\circ\text{C}$ . What is this expressed in degrees Fahrenheit?
  
10. Convert  $17^\circ\text{C}$  to degrees Fahrenheit.
  
11. What is the density of a substance in pounds per cubic foot if it weighs  $29.27 \text{ kg}$  and occupies a space of  $0.985 \text{ ft}^3$ ?
  
12. A certain pump delivers  $14 \text{ gallons per minute}$ .
  - a. How many lbs of water does the pump deliver in 24 hours?
  
  - b. How many lbs/day will the pump deliver if the liquid weighs  $8.1 \text{ lb/gal}$ ?
  
13. A tank holds  $1,240 \text{ gallons}$  of a certain liquid. The specific gravity is  $0.93$ . How many pounds of liquid are in the tank?

14. Convert 43°C to degrees Fahrenheit.
  
15. The influent to a treatment plant has a temperature of 75°F. what is the temperature expressed in degrees Celsius?
  
16. What is the specific gravity for a solution that weighs 9.44 lb/gal?
  
17. To preserve a bacteriological sample, the sample must be cooled to 4°C. What is this expressed in degrees Fahrenheit?
  
18. Determine the specific gravity of a gold bar that weighs 521.47 lb and occupies a space of 0.433 ft<sup>3</sup>.
  
19. A certain pump delivers 23 gallons per minute.
  - a. How many lbs of water does the pump deliver in 1 minute?
  
  
  - b. How many lbs/min will the pump deliver if the liquid weighs 71.9 lbs/ft<sup>3</sup>?
  
20. Find the density (lbs/gal) of ferric chloride that has a S.G. of 1.140.

21. Find the density ( $\text{lbs}/\text{ft}^3$ ) of potassium permanganate that has a S.G. of 1.522.
22. What is the specific gravity of an unknown liquid that has a density of  $68.4 \text{ lb}/\text{ft}^3$ ?
23. How many pounds of liquid can be pumped per day?  
Pump rate desired: 25 gpm  
Liquid weight: 74.9  $\text{lbs}/\text{ft}^3$

<b>Laboratory Calculations Answers</b>	
1.)	13.)
2.)	14.)
3.)	15.)
4.)	16.)
5.)	17.)
6.)	18.)
7.)	19.) a.
8.)	b.
9.)	20.)
10.)	21.)
11.)	22.)
12.) a.	23.)
b.	